

# A Comparative Analysis of the Neuroprotective Efficacy of Geniposide and Other Iridoids

**Author:** BenchChem Technical Support Team. **Date:** December 2025

## Compound of Interest

Compound Name: *Geniposide*

Cat. No.: *B1672800*

[Get Quote](#)

For Researchers, Scientists, and Drug Development Professionals

Iridoids, a class of monoterpenoids, have garnered significant attention for their diverse pharmacological activities, including potent neuroprotective effects. This guide provides a comparative analysis of the neuroprotective efficacy of **geniposide** against other prominent iridoids, namely catalpol and loganin. The information presented herein is supported by experimental data from peer-reviewed studies, with a focus on quantitative comparisons, detailed methodologies, and the underlying molecular mechanisms.

## Data Presentation: A Quantitative Comparison

The following tables summarize the neuroprotective effects of **geniposide**, catalpol, and loganin in various in vitro and in vivo models of neuronal injury. The data highlights key parameters such as cell viability, apoptosis rates, and reduction of reactive oxygen species (ROS).

Table 1: In Vitro Neuroprotective Efficacy of Iridoids in PC12 Cells

Iridoid	Model of Injury	Concentration	Outcome Measure	Result	Reference
Geniposide	Corticosterone-induced	Not Specified	Cell Viability (MTT)	Significant Improvement	[1]
Apoptosis Rate	Significant Inhibition	[1]			
Intracellular ROS	Significant Reduction	[1]			
H <sub>2</sub> O <sub>2</sub> -induced	Not Specified	Cell Viability (MTT)	Increased from 51.7% to 77.9%	[2]	
Apoptosis Rate	Decreased from 42.7% to 15.9%	[2]			
LPS-induced	200 or 300 µg/mL	Cell Viability (CCK-8)	Significantly mitigated viability loss	[3]	
Catalpol	Corticosterone-induced	Not Specified	Cell Viability (MTT)	Significant Improvement	[1]
Apoptosis Rate	Significant Inhibition	[1]			
Intracellular ROS	Significant Reduction	[1]			
H <sub>2</sub> O <sub>2</sub> -induced	12.5, 25, and 50 µM	Intracellular ROS	Significant Decrease	[4][5]	
25 and 50 µM	MDA Levels	Significant Decrease	[4][5]		
Loganin	Aβ <sub>25-35</sub> -induced	Not Specified	Cell Death	Predominantly Prevented	[6]

ROS Generation	Suppressed	[6]
Apoptosis	Attenuated	[6]

Table 2: In Vivo Neuroprotective Efficacy of Iridoids

Iridoid	Animal Model	Injury Model	Dosage	Outcome Measure	Result	Reference
Geniposide	Mice	MCAO	150 mg/kg	Infarct Volume	Reduced from 54.73% to 45.10%	[3]
Brain Edema					Reduced from 82.28% to 79.00%	[3]
Mice	Rotenone-induced PD	25 and 50 mg/kg	Motor Dysfunction	Improved		[7][8]
Catalpol	Mice	MPTP-induced PD	Not Specified	Dopaminergic Neuron Loss	Mitigated	[9]
Loganin	Rats	Intracerebral Hemorrhage	2.5, 5, and 10 mg/kg	Neurological Function	Significant Improvement	[10]

## Experimental Protocols

Detailed methodologies for the key experiments cited are provided below to facilitate replication and further research.

## Cell Viability Assessment (MTT Assay)

The 3-(4,5-dimethylthiazol-2-yl)-2,5-diphenyltetrazolium bromide (MTT) assay is a colorimetric assay for assessing cell metabolic activity.

- **Cell Seeding:** Plate PC12 cells in 96-well plates at a density of  $1 \times 10^5$  cells/mL and culture for 24 hours.
- **Treatment:** Treat the cells with the desired concentrations of iridoids for a specified duration, followed by induction of neuronal injury (e.g., with H<sub>2</sub>O<sub>2</sub> or corticosterone).
- **MTT Incubation:** After treatment, add 20  $\mu$ L of MTT solution (5 mg/mL in PBS) to each well and incubate for 4 hours at 37°C.
- **Solubilization:** Remove the supernatant and add 150  $\mu$ L of dimethyl sulfoxide (DMSO) to each well to dissolve the formazan crystals.
- **Absorbance Measurement:** Measure the absorbance at 570 nm using a microplate reader. Cell viability is expressed as a percentage of the control group.[\[11\]](#)[\[12\]](#)

## Apoptosis Detection (Annexin V-FITC/PI Staining)

This flow cytometry-based assay distinguishes between viable, apoptotic, and necrotic cells.

- **Cell Preparation:** After treatment, harvest the cells by trypsinization and wash twice with cold PBS.
- **Staining:** Resuspend the cells in 1X Annexin-binding buffer. Add Annexin V-FITC and propidium iodide (PI) to the cell suspension.
- **Incubation:** Incubate the cells for 15 minutes at room temperature in the dark.
- **Flow Cytometry Analysis:** Add 400  $\mu$ L of 1X Annexin-binding buffer and analyze the cells by flow cytometry. Annexin V-positive/PI-negative cells are considered early apoptotic, while Annexin V-positive/PI-positive cells are late apoptotic or necrotic.[\[1\]](#)[\[13\]](#)[\[14\]](#)

## Measurement of Intracellular Reactive Oxygen Species (ROS)

The 2',7'-dichlorodihydrofluorescein diacetate (DCFH-DA) assay is used to measure intracellular ROS levels.

- **Cell Treatment:** Seed cells in a 96-well plate and treat with iridoids and the inducing agent.
- **DCFH-DA Staining:** Wash the cells with serum-free medium and then incubate with DCFH-DA solution (typically 10  $\mu$ M) for 30 minutes at 37°C.
- **Fluorescence Measurement:** After incubation, wash the cells to remove excess probe and measure the fluorescence intensity using a fluorescence microplate reader with excitation and emission wavelengths of approximately 485 nm and 535 nm, respectively.[\[15\]](#)[\[16\]](#)[\[17\]](#)

## Middle Cerebral Artery Occlusion (MCAO) Model in Mice

This in vivo model is used to simulate ischemic stroke.

- **Anesthesia and Incision:** Anesthetize the mouse and make a midline neck incision to expose the common carotid artery (CCA).
- **Vessel Isolation:** Carefully separate the external carotid artery (ECA) and internal carotid artery (ICA).
- **Occlusion:** Introduce a nylon monofilament through the ECA into the ICA to occlude the origin of the middle cerebral artery (MCA).
- **Reperfusion (optional):** For transient MCAO, the filament is withdrawn after a specific period (e.g., 1-2 hours) to allow reperfusion.
- **Assessment:** Evaluate neurological deficits, and determine infarct volume and brain edema at a designated time point (e.g., 24 hours) post-MCAO.[\[10\]](#)[\[18\]](#)[\[19\]](#)

## Signaling Pathways and Mechanisms of Action

The neuroprotective effects of **geniposide**, catalpol, and loganin are mediated through the modulation of various signaling pathways, primarily targeting anti-inflammatory, anti-apoptotic,

and antioxidant mechanisms.

## Geniposide

**Geniposide** exerts its neuroprotective effects through multiple pathways:

- **PI3K/Akt Pathway:** **Geniposide** activates the PI3K/Akt signaling pathway, which promotes cell survival and inhibits apoptosis.[2][19]
- **NF-κB Pathway:** It inhibits the activation of the NF-κB pathway, thereby reducing the production of pro-inflammatory cytokines.[3]
- **MAPK Pathway:** **Geniposide** can modulate the MAPK pathway to protect against oxidative damage.[20]
- **Nrf2 Pathway:** It can suppress neuronal oxidative damage through the Nrf2 antioxidant signaling pathway.[7]
- **mTOR Pathway:** **Geniposide** is also involved in the anti-apoptosis pathway regulated by mTOR.[7]

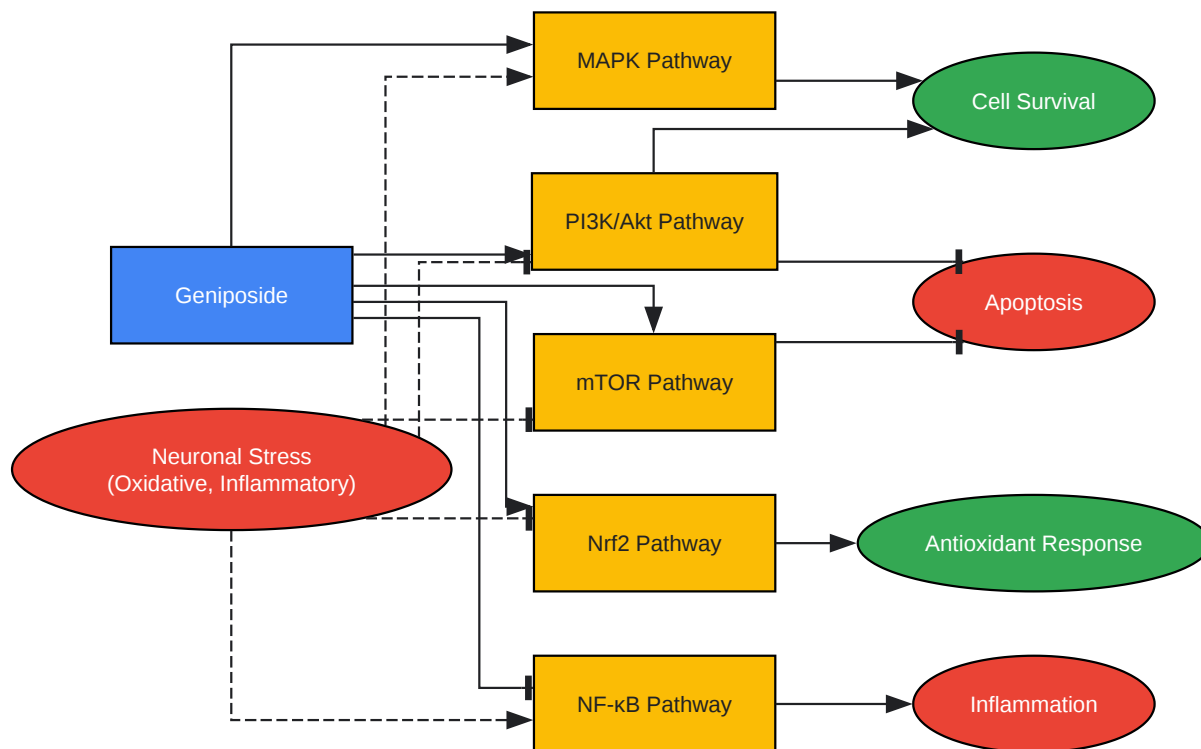

[Click to download full resolution via product page](#)

Caption: **Geniposide's** neuroprotective signaling pathways.

## Catalpol

Catalpol's neuroprotective mechanisms are also multifaceted:

- Anti-apoptotic Pathways: It regulates the expression of Bcl-2 family proteins, inhibiting the mitochondrial apoptosis pathway.[21]
- Anti-inflammatory Pathways: Catalpol attenuates neuroinflammation by inhibiting the NF-κB signaling pathway.[2]
- Antioxidant Pathways: It enhances the activity of antioxidant enzymes and activates the Keap1/Nrf2 pathway to combat oxidative stress.[2][4][5]

- CaMKII-dependent Pathway: Catalpol can block the CaMKII-dependent ASK-1/JNK/p38 signaling cascade to reduce apoptosis.[22][23]

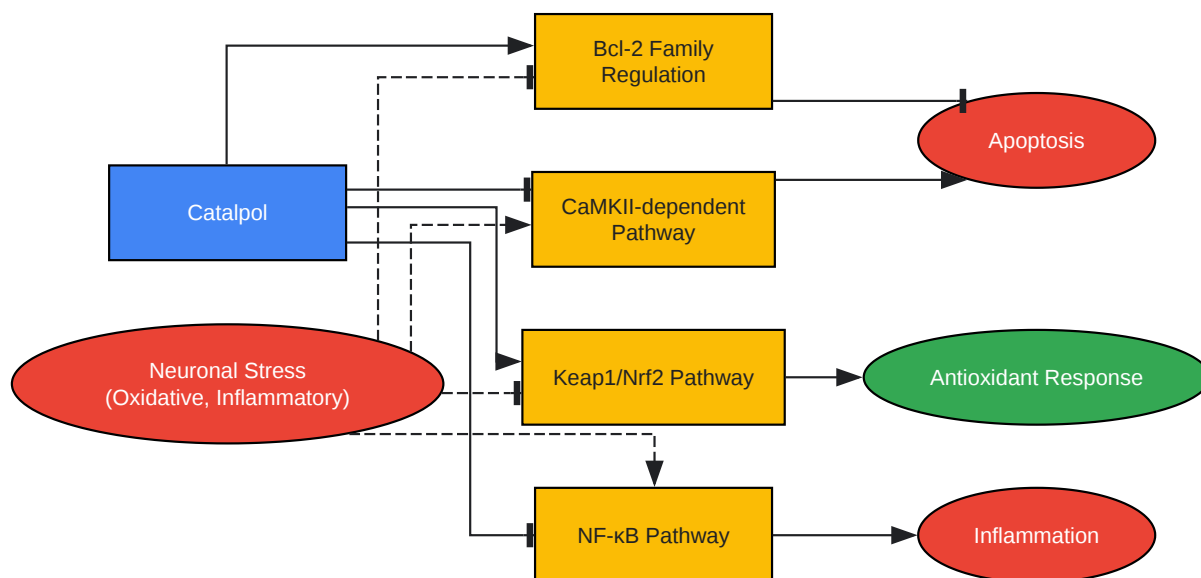

[Click to download full resolution via product page](#)

Caption: Catalpol's neuroprotective signaling pathways.

## Loganin

Loganin demonstrates neuroprotection through several key mechanisms:

- Anti-inflammatory Effects: It suppresses neuroinflammatory responses by inhibiting the activation of NF-κB and reducing the production of pro-inflammatory cytokines.[6][14]
- Antioxidant Properties: Loganin effectively reduces the generation of reactive oxygen species.[6]
- Neurotrophic Signaling: It enhances neurotrophic signaling by activating IGF-1R/GLP-1R pathways.[18][24]
- Inhibition of Apoptosis: Loganin attenuates apoptosis by inhibiting caspase-3 activity.[6]



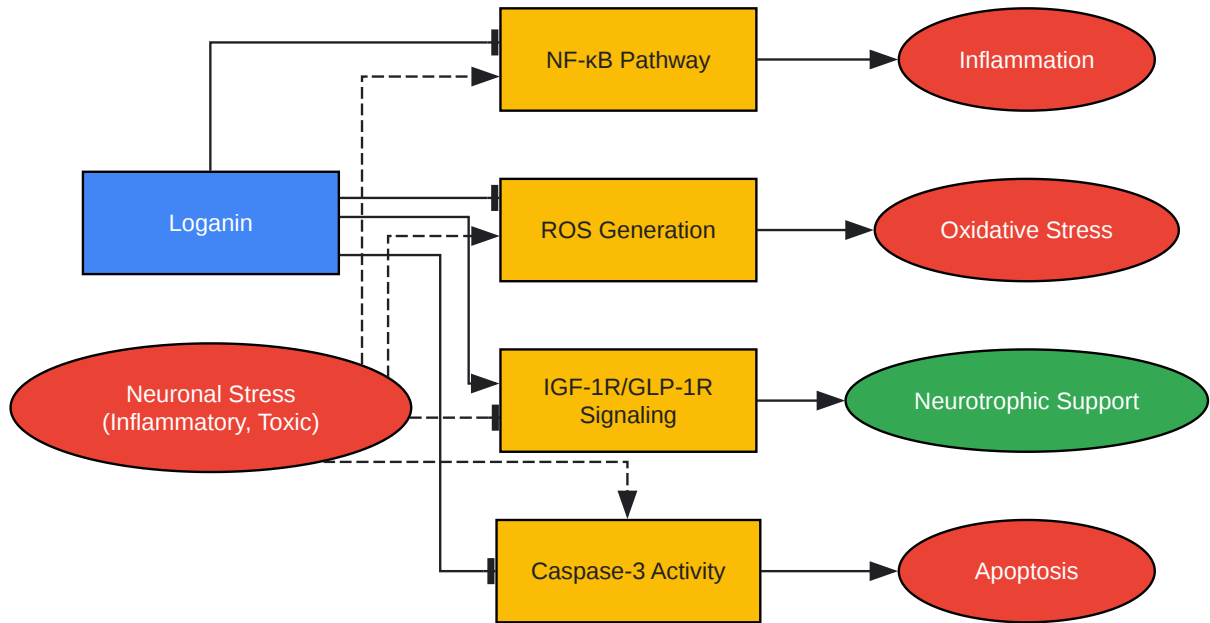

[Click to download full resolution via product page](#)

Caption: Loganin's neuroprotective signaling pathways.

## Experimental Workflow Visualization

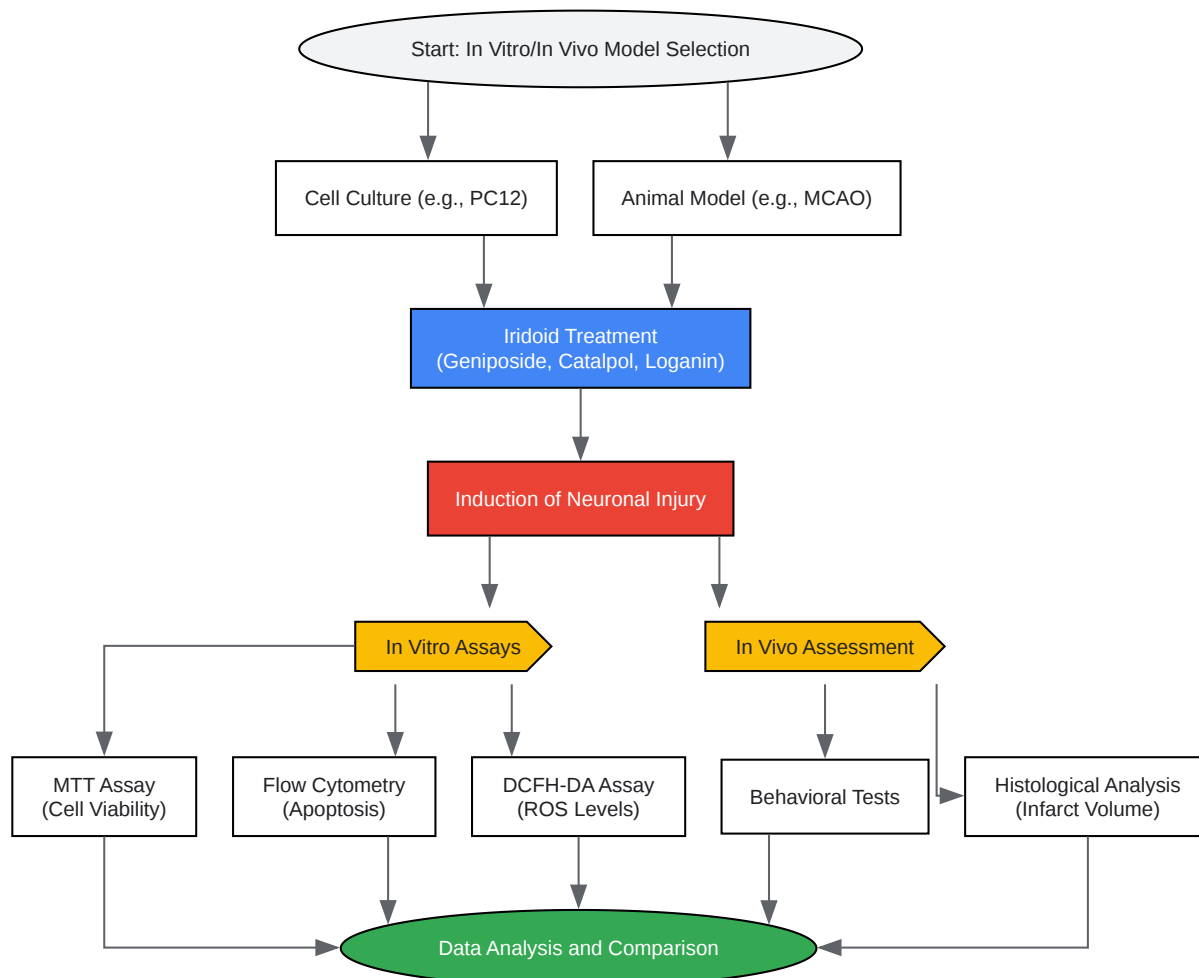

[Click to download full resolution via product page](#)

Caption: General experimental workflow for neuroprotection studies.

In conclusion, **geniposide**, catalpol, and loganin all exhibit significant neuroprotective properties through overlapping yet distinct molecular mechanisms. The choice of a particular iridoid for therapeutic development may depend on the specific neuropathological context, with all three compounds demonstrating promise in mitigating neuronal damage through anti-

inflammatory, anti-apoptotic, and antioxidant activities. This guide provides a foundational comparison to aid researchers in their ongoing efforts to develop novel neuroprotective agents.

### Need Custom Synthesis?

BenchChem offers custom synthesis for rare earth carbides and specific isotopic labeling.

Email: [info@benchchem.com](mailto:info@benchchem.com) or [Request Quote Online](#).

## References

- 1. kumc.edu [kumc.edu]
- 2. Neuroprotection of geniposide against hydrogen peroxide induced PC12 cells injury: involvement of PI3 kinase signal pathway - PMC [pmc.ncbi.nlm.nih.gov]
- 3. Geniposide protects PC12 cells from lipopolysaccharide-evoked inflammatory injury via up-regulation of miR-145-5p - PubMed [pubmed.ncbi.nlm.nih.gov]
- 4. Frontiers | Neuroprotective Effect of Catalpol via Anti-Oxidative, Anti-Inflammatory, and Anti-Apoptotic Mechanisms [frontiersin.org]
- 5. researchgate.net [researchgate.net]
- 6. Neuroprotective effect of loganin against A $\beta$ 25-35-induced injury via the NF- $\kappa$ B-dependent signaling pathway in PC12 cells - PubMed [pubmed.ncbi.nlm.nih.gov]
- 7. Neuroprotection of geniposide against hydrogen peroxide induced PC12 cells injury: involvement of PI3 kinase signal pathway - PubMed [pubmed.ncbi.nlm.nih.gov]
- 8. Geniposide protects against neurotoxicity in mouse models of rotenone-induced Parkinson's disease involving the mTOR and Nrf2 pathways - PubMed [pubmed.ncbi.nlm.nih.gov]
- 9. Catalpol Exerts a Neuroprotective Effect in the MPTP Mouse Model of Parkinson's Disease - PubMed [pubmed.ncbi.nlm.nih.gov]
- 10. Protocol for middle cerebral artery occlusion by an intraluminal suture method - PMC [pmc.ncbi.nlm.nih.gov]
- 11. Plate reader-based assays for measuring cell viability, neuroprotection and calcium in primary neuronal cultures - PMC [pmc.ncbi.nlm.nih.gov]
- 12. MTT Assay Protocol | Springer Nature Experiments [experiments.springernature.com]

- 13. Protocol for Apoptosis Assay by Flow Cytometry Using Annexin V Staining Method - PubMed [pubmed.ncbi.nlm.nih.gov]
- 14. Annexin V staining assay protocol for apoptosis | Abcam [abcam.com]
- 15. Detection of Total Reactive Oxygen Species in Adherent Cells by 2',7'-Dichlorodihydrofluorescein Diacetate Staining - PMC [pmc.ncbi.nlm.nih.gov]
- 16. arigobio.com [arigobio.com]
- 17. doc.abcam.com [doc.abcam.com]
- 18. Intraluminal middle cerebral artery occlusion (MCAO) model for ischemic stroke with laser doppler flowmetry guidance in mice - PubMed [pubmed.ncbi.nlm.nih.gov]
- 19. Mouse Model of Middle Cerebral Artery Occlusion - PMC [pmc.ncbi.nlm.nih.gov]
- 20. The emerging possibility of the use of geniposide in the treatment of cerebral diseases: a review - PMC [pmc.ncbi.nlm.nih.gov]
- 21. scienceopen.com [scienceopen.com]
- 22. Neuroprotective activities of catalpol against CaMKII-dependent apoptosis induced by LPS in PC12 cells - PMC [pmc.ncbi.nlm.nih.gov]
- 23. Neuroprotective activities of catalpol against CaMKII-dependent apoptosis induced by LPS in PC12 cells - PubMed [pubmed.ncbi.nlm.nih.gov]
- 24. The novel protective effects of loganin against 1-methyl-4-phenylpyridinium-induced neurotoxicity: Enhancement of neurotrophic signaling, activation of IGF-1R/GLP-1R, and inhibition of RhoA/ROCK pathway - PubMed [pubmed.ncbi.nlm.nih.gov]
- To cite this document: BenchChem. [A Comparative Analysis of the Neuroprotective Efficacy of Geniposide and Other Iridoids]. BenchChem, [2025]. [Online PDF]. Available at: [https://www.benchchem.com/product/b1672800#comparing-the-neuroprotective-efficacy-of-geniposide-with-other-iridoids]

---

### Disclaimer & Data Validity:

The information provided in this document is for Research Use Only (RUO) and is strictly not intended for diagnostic or therapeutic procedures. While BenchChem strives to provide accurate protocols, we make no warranties, express or implied, regarding the fitness of this product for every specific experimental setup.

**Technical Support:** The protocols provided are for reference purposes. Unsure if this reagent suits your experiment? [[Contact our Ph.D. Support Team for a compatibility check](#)]

**Need Industrial/Bulk Grade?** [Request Custom Synthesis Quote](#)

## BenchChem

Our mission is to be the trusted global source of essential and advanced chemicals, empowering scientists and researchers to drive progress in science and industry.

### Contact

Address: 3281 E Guasti Rd  
Ontario, CA 91761, United States  
Phone: (601) 213-4426  
Email: [info@benchchem.com](mailto:info@benchchem.com)