

Technical Support Center: Optimizing In Vivo Efficacy of GK187

Author: BenchChem Technical Support Team. **Date:** April 2026

Compound of Interest

Compound Name:	GK187
CAS No.:	1071001-50-7
Cat. No.:	B1671567

[Get Quote](#)

This technical support center provides researchers, scientists, and drug development professionals with comprehensive troubleshooting guides and frequently asked questions (FAQs) to enhance the in vivo efficacy of **GK187**, a selective inhibitor of Group VIA calcium-independent phospholipase A2 (iPLA₂).

Troubleshooting Guide

This guide addresses common issues encountered during in vivo experiments with **GK187** and offers structured solutions.

Issue	Potential Cause	Recommended Solution
1. Lack of In Vivo Efficacy Despite In Vitro Potency	Poor bioavailability due to formulation issues.	Review and optimize the formulation. GK187 is soluble in DMF (10 mg/ml), DMSO (10 mg/ml), and Ethanol (10 mg/ml). For in vivo administration, a solution in Ethanol:PBS (pH 7.2) at a 1:2 ratio is suggested, with a solubility of 0.3 mg/ml.[1] Consider co-solvents like PEG or surfactants such as Tween 80 to improve solubility and stability.[2] Always include a vehicle-only control group to assess any effects of the formulation itself.[2]
Inadequate dose or dosing frequency.	Conduct a Maximum Tolerated Dose (MTD) study to determine the highest safe dose.[2] Use in vitro IC50 or EC50 values to estimate a starting dose for the MTD study, aiming for a plasma concentration several-fold higher.[2] Perform a dose-response study to identify the optimal dose for efficacy.	

<p>Rapid metabolism or clearance of GK187.</p>	<p>Perform pharmacokinetic (PK) studies to determine the half-life, clearance, and volume of distribution of GK187.[3][4] Adjust the dosing frequency based on the PK profile to maintain therapeutic concentrations.</p>	
<p>2. High Variability in Efficacy Data</p>	<p>Inconsistent dosing technique or animal handling.</p>	<p>Ensure all personnel are thoroughly trained in the chosen administration route (e.g., oral gavage, intraperitoneal injection). Standardize animal handling procedures to minimize stress, which can impact physiological responses.</p>
<p>Biological variability within the animal model.</p>	<p>Increase the number of animals per group to improve statistical power. Ensure the animal model is appropriate and well-characterized for the disease being studied.</p>	
<p>3. Unexpected Toxicity</p>	<p>Off-target effects of GK187.</p>	<p>While GK187 is selective for GVIA iPLA₂ over GIVA cPLA₂ and GV sPLA₂, off-target effects can still occur at higher concentrations.[1] Conduct a thorough toxicological assessment, including histopathology of major organs.</p>
<p>Vehicle-related toxicity.</p>	<p>Always include a vehicle-only control group to differentiate</p>	

between compound- and
vehicle-induced toxicity.[2]

Frequently Asked Questions (FAQs)

Q1: What is the mechanism of action of **GK187**?

A1: **GK187** is a potent and selective inhibitor of Group VIA calcium-independent phospholipase A₂ (iPLA₂).[1] iPLA₂ is an enzyme involved in basal cell metabolism and the generation of lipid second messengers. By inhibiting iPLA₂, **GK187** can modulate downstream signaling pathways involved in inflammation and other cellular processes.

Q2: How should I prepare **GK187** for in vivo administration?

A2: Based on its solubility profile, **GK187** can be dissolved in DMF, DMSO, or ethanol.[1] For in vivo studies, a common practice is to prepare a stock solution in a suitable organic solvent and then dilute it with a pharmaceutically acceptable vehicle, such as a mixture of Ethanol and PBS (pH 7.2) at a 1:2 ratio.[1] It is crucial to perform a small-scale formulation test to ensure the compound remains in solution at the desired concentration and does not precipitate upon dilution.

Q3: What are the key initial in vivo studies to conduct with **GK187**?

A3: The first essential study is a Maximum Tolerated Dose (MTD) study to establish a safe dosing range.[2] Following the MTD, a pharmacokinetic (PK) study is recommended to understand the absorption, distribution, metabolism, and excretion (ADME) profile of **GK187**. [3] [4] Subsequently, a dose-response efficacy study should be performed using doses below the MTD.[2]

Q4: How can I confirm that **GK187** is hitting its target in vivo?

A4: A pharmacodynamic (PD) study is necessary to demonstrate target engagement.[2] This involves collecting tissue samples from treated animals at various time points and measuring the activity of iPLA₂ or the levels of its downstream products.

Experimental Protocols

Maximum Tolerated Dose (MTD) Study

Objective: To determine the highest dose of **GK187** that can be administered without causing unacceptable toxicity.

Methodology:

- Select a suitable animal model (e.g., mice or rats).
- Based on in vitro data, select a starting dose expected to produce a plasma concentration several-fold higher than the IC50 value.[\[2\]](#)
- Administer escalating doses of **GK187** to different groups of animals.
- Monitor animals daily for clinical signs of toxicity (e.g., weight loss, changes in behavior, ruffled fur).
- The MTD is defined as the highest dose that does not cause significant morbidity or more than a predefined level of body weight loss (typically 15-20%).

Pharmacokinetic (PK) Study

Objective: To characterize the pharmacokinetic profile of **GK187**.

Methodology:

- Administer a single dose of **GK187** to a cohort of animals at a dose known to be well-tolerated.
- Collect blood samples at multiple time points post-administration (e.g., 0, 15 min, 30 min, 1h, 2h, 4h, 8h, 24h).
- Process blood samples to isolate plasma.
- Analyze plasma concentrations of **GK187** using a validated analytical method (e.g., LC-MS/MS).

- Calculate key PK parameters such as C_{max}, T_{max}, AUC, half-life, clearance, and volume of distribution.^{[3][4][5]}

Visualizations

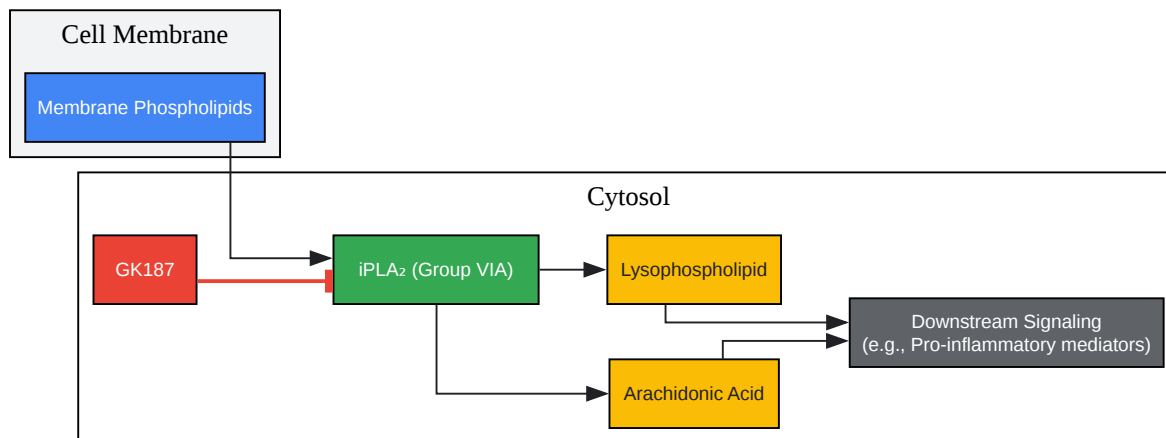

[Click to download full resolution via product page](#)

Caption: **GK187** inhibits iPLA₂ to block downstream signaling.

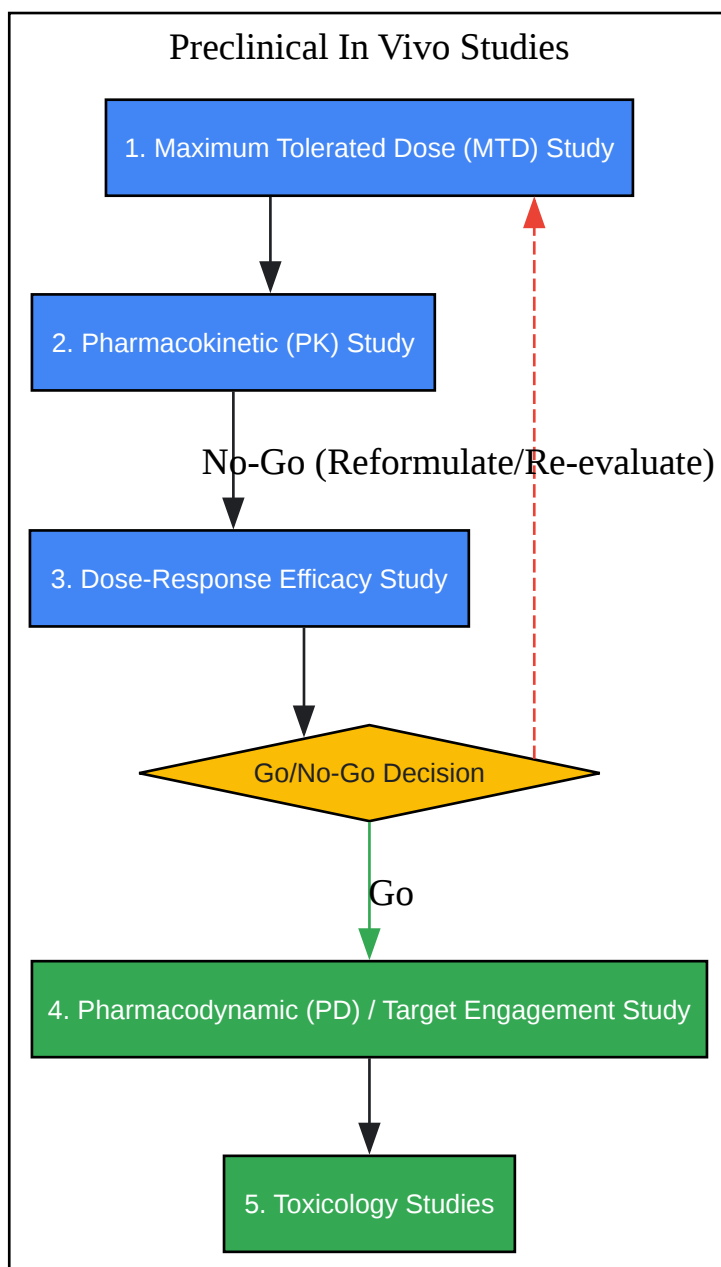

[Click to download full resolution via product page](#)

Caption: Workflow for in vivo evaluation of **GK187**.

Need Custom Synthesis?

BenchChem offers custom synthesis for rare earth carbides and specific isotopic labeling.

Email: info@benchchem.com or [Request Quote Online](#).

References

- [1. caymanchem.com \[caymanchem.com\]](https://www.caymanchem.com)
- [2. benchchem.com \[benchchem.com\]](https://www.benchchem.com)
- [3. ashp.org \[ashp.org\]](https://www.ashp.org)
- [4. Redirecting \[linkinghub.elsevier.com\]](https://linkinghub.elsevier.com)
- [5. Pharmacokinetics and Pharmacodynamics of Lysergic Acid Diethylamide in Healthy Subjects - PubMed \[pubmed.ncbi.nlm.nih.gov\]](https://pubmed.ncbi.nlm.nih.gov)
- To cite this document: BenchChem. [Technical Support Center: Optimizing In Vivo Efficacy of GK187]. BenchChem, [2026]. [Online PDF]. Available at: [\[https://www.benchchem.com/product/b1671567/docs#technical-support-center-optimizing-in-vivo-efficacy-of-gk187\]](https://www.benchchem.com/product/b1671567/docs#technical-support-center-optimizing-in-vivo-efficacy-of-gk187)

Disclaimer & Data Validity:

The information provided in this document is for Research Use Only (RUO) and is strictly not intended for diagnostic or therapeutic procedures. While BenchChem strives to provide accurate protocols, we make no warranties, express or implied, regarding the fitness of this product for every specific experimental setup.

Technical Support: The protocols provided are for reference purposes. Unsure if this reagent suits your experiment?

Need Industrial/Bulk Grade? [Request Custom Synthesis Quote](#)

BenchChem

Our mission is to be the trusted global source of essential and advanced chemicals, empowering scientists and researchers to drive progress in science and industry.

Contact

Address: 3281 E Guasti Rd
Ontario, CA 91761, United States
Phone: (601) 213-4426
Email: info@benchchem.com

Contact our Ph.D. Support Team for a compatibility check