

Refining Emd 55068 administration protocols for long-term studies

Author: BenchChem Technical Support Team. **Date:** April 2026

Compound of Interest

Compound Name: Emd 55068
CAS No.: 126784-34-7
Cat. No.: B1671208

[Get Quote](#)

Technical Support Center: EMD 55068 Administration Protocols

Disclaimer: Information regarding **EMD 55068** is limited in publicly available scientific literature. The following protocols, troubleshooting guides, and FAQs have been developed based on data from structurally and functionally related thiadiazinone derivatives, such as EMD 53998 and EMD 57033. Researchers should use this information as a starting point and perform their own optimization and validation studies.

Frequently Asked Questions (FAQs)

Q1: What is the primary mechanism of action for **EMD 55068**?

A1: Based on related compounds, **EMD 55068** is presumed to be a Ca²⁺-sensitizing agent. It likely acts as a cardiac troponin C (cTnC) activator, enhancing the sensitivity of the myofilaments to calcium. This leads to an increase in myocardial contractility without a significant increase in intracellular calcium concentrations. Some related compounds also

exhibit phosphodiesterase III (PDE III) inhibitory effects, which can contribute to their inotropic effects.

Q2: What is the recommended solvent for **EMD 55068**?

A2: **EMD 55068** is expected to be poorly soluble in aqueous solutions. For in vitro experiments, Dimethyl Sulfoxide (DMSO) is a common solvent for preparing stock solutions of related compounds. For in vivo studies, careful formulation with vehicles such as a mixture of DMSO, Cremophor EL, and saline is often necessary to ensure solubility and bioavailability while minimizing toxicity.

Q3: What are the potential off-target effects of **EMD 55068**?

A3: While specific off-target effects for **EMD 55068** are not documented, researchers should be aware of potential effects observed with similar compounds. These may include inhibition of phosphodiesterases other than PDE III and potential interactions with other ion channels or receptors. Comprehensive off-target screening is recommended for long-term studies.

Q4: How should **EMD 55068** be stored?

A4: As with most research compounds, **EMD 55068** should be stored in a cool, dry, and dark place. For long-term storage, it is advisable to store it as a solid at -20°C or below. Stock solutions in DMSO should also be stored at -20°C in small aliquots to avoid repeated freeze-thaw cycles.

Troubleshooting Guides

Problem	Possible Cause	Suggested Solution
Compound Precipitation in Formulation	Poor solubility of EMD 55068 in the chosen vehicle.	<ul style="list-style-type: none"> - Increase the percentage of co-solvents like DMSO or Cremophor EL in the vehicle, while considering potential toxicity. - Prepare fresh formulations immediately before each administration. - Use sonication or gentle warming to aid dissolution, but be cautious of compound degradation.
Inconsistent Results in Long-Term Studies	<ul style="list-style-type: none"> - Degradation of the compound in the formulation over time. - Variability in drug administration (e.g., injection site, volume). 	<ul style="list-style-type: none"> - Assess the stability of EMD 55068 in the chosen vehicle over the intended period of use. - Standardize administration procedures meticulously. Ensure consistent injection volumes, sites, and timing.
Observed Toxicity or Adverse Events in Animals	<ul style="list-style-type: none"> - Toxicity of the compound itself. - Toxicity of the vehicle, especially with high concentrations of DMSO or Cremophor EL. 	<ul style="list-style-type: none"> - Perform a dose-response study to determine the maximum tolerated dose (MTD). - Include a vehicle-only control group in all experiments to assess the effects of the formulation components. - Consider alternative, less toxic vehicles if possible.
Lack of Expected Efficacy	<ul style="list-style-type: none"> - Inadequate dosing or bioavailability. - Degradation of the compound. 	<ul style="list-style-type: none"> - Increase the dose, being mindful of potential toxicity. - Analyze the pharmacokinetic profile of EMD 55068 in your animal model to ensure

adequate exposure. - Verify the integrity and purity of your compound stock.

Experimental Protocols

In Vivo Administration Protocol for a Rodent Model (Illustrative)

1. Materials:

- **EMD 55068** powder
- Dimethyl Sulfoxide (DMSO, sterile, cell culture grade)
- Cremophor EL
- Sterile Saline (0.9% NaCl)
- Sterile, light-protected microcentrifuge tubes
- Vortex mixer
- Sonicator (optional)
- Appropriate syringes and needles for the chosen route of administration

2. Formulation Preparation (Example for a 1 mg/mL solution):

- Step 1: Weigh the required amount of **EMD 55068** powder in a sterile microcentrifuge tube.
- Step 2: Add DMSO to a final concentration of 10% of the total volume (e.g., 100 μ L for a 1 mL final volume). Vortex thoroughly until the compound is completely dissolved.
- Step 3: Add Cremophor EL to a final concentration of 10% of the total volume (e.g., 100 μ L). Vortex to mix.
- Step 4: Slowly add sterile saline to reach the final desired volume, vortexing intermittently to ensure a homogenous suspension.
- Step 5: Protect the formulation from light and prepare it fresh before each use. If sonication is used to aid dissolution, use a water bath sonicator and avoid excessive heat.

3. Administration:

- The route of administration (e.g., intraperitoneal, intravenous, oral gavage) will depend on the experimental design and the pharmacokinetic properties of the compound.
- Administer the formulation at the desired dose. For long-term studies, consider the use of osmotic pumps for continuous delivery to maintain stable plasma concentrations.

- Always include a vehicle control group receiving the same formulation without **EMD 55068**.

Quantitative Data Summary

The following tables present hypothetical data based on the expected effects of a Ca²⁺-sensitizing agent like **EMD 55068**. These are for illustrative purposes only.

Table 1: In Vitro Efficacy of **EMD 55068** on Cardiac Myocytes

Concentration (μM)	Increase in Contractile Force (%)	Change in Intracellular Ca ²⁺ Amplitude (%)
0.1	15 ± 3	2 ± 1
1	45 ± 5	5 ± 2
10	85 ± 8	8 ± 3
100	95 ± 7	10 ± 4

Table 2: In Vivo Hemodynamic Effects of **EMD 55068** in a Rodent Model of Heart Failure

Treatment Group	Ejection Fraction (%)	Cardiac Output (mL/min)	Heart Rate (bpm)
Vehicle Control	30 ± 4	25 ± 3	350 ± 20
EMD 55068 (1 mg/kg)	40 ± 5	32 ± 4	355 ± 22
EMD 55068 (5 mg/kg)	52 ± 6	40 ± 5	360 ± 18

Visualizations

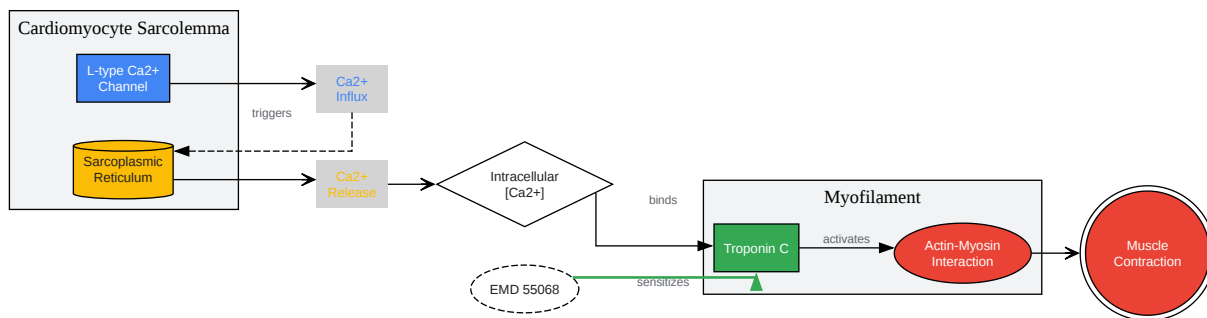

[Click to download full resolution via product page](#)

Caption: Proposed signaling pathway of **EMD 55068** in cardiomyocytes.

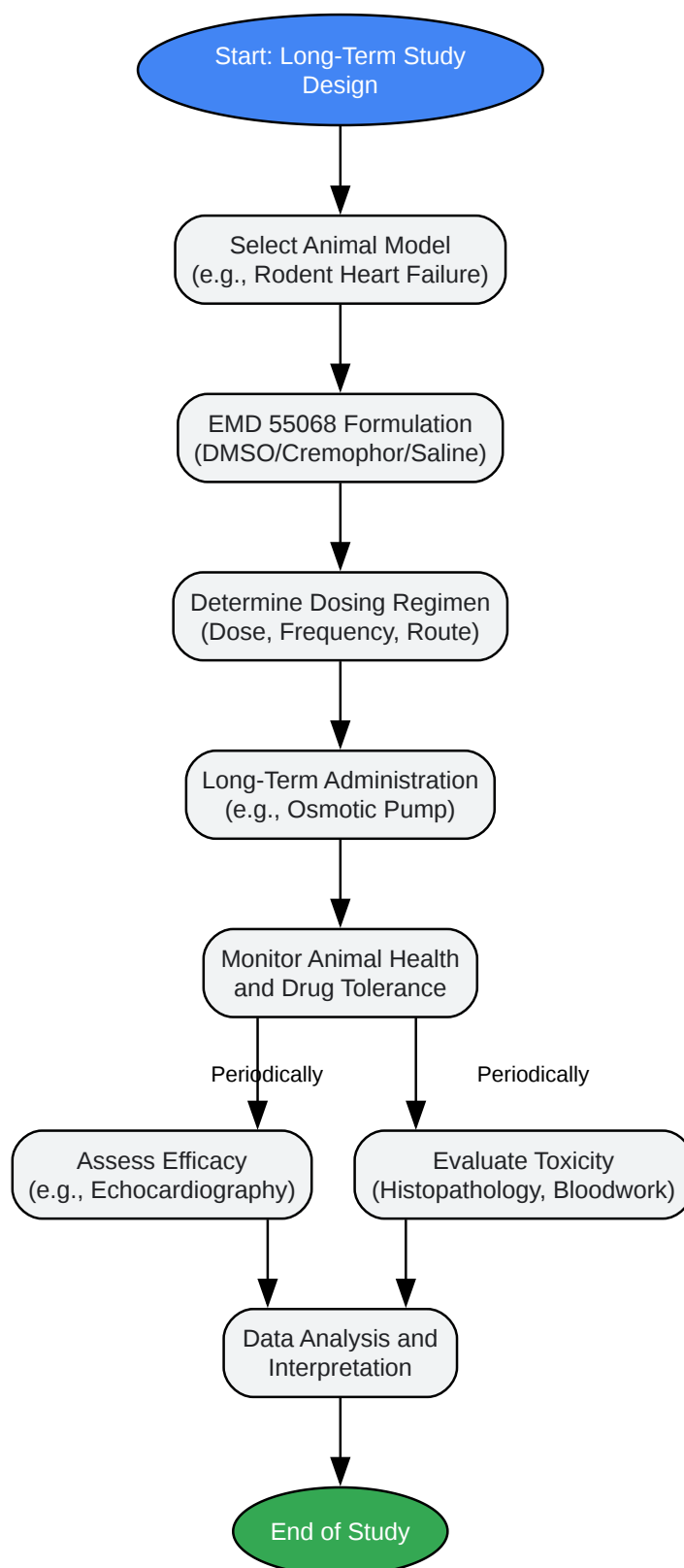

[Click to download full resolution via product page](#)

Caption: General experimental workflow for long-term studies with **EMD 55068**.

- To cite this document: BenchChem. [Refining Emd 55068 administration protocols for long-term studies]. BenchChem, [2026]. [Online PDF]. Available at: [<https://www.benchchem.com/product/b1671208/docs#refining-emd-55068-administration-protocols-for-long-term-studies>]

Disclaimer & Data Validity:

The information provided in this document is for Research Use Only (RUO) and is strictly not intended for diagnostic or therapeutic procedures. While BenchChem strives to provide accurate protocols, we make no warranties, express or implied, regarding the fitness of this product for every specific experimental setup.

Technical Support: The protocols provided are for reference purposes. Unsure if this reagent suits your experiment?

Need Industrial/Bulk Grade? [Request Custom Synthesis Quote](#)

BenchChem

Our mission is to be the trusted global source of essential and advanced chemicals, empowering scientists and researchers to drive progress in science and industry.

Contact

Address: 3281 E Guasti Rd
Ontario, CA 91761, United States
Phone: (601) 213-4426
Email: info@benchchem.com

[Contact our Ph.D. Support Team for a compatibility check](#)