

Comparative Guide: Validating the Enniatin C Mechanism via p53 Knockout Models

Author: BenchChem Technical Support Team. **Date:** May 2026

Compound of Interest

Compound Name:	Enniatin C
CAS No.:	19893-23-3
Cat. No.:	B1671337

[Get Quote](#)

Executive Summary

Enniatin C (ENN C), a cyclohexadepsipeptide mycotoxin produced by *Fusarium* species, is gaining attention as a potential anticancer agent due to its ionophoric properties. While its structural analog, Enniatin B, is well-characterized, the precise mechanistic dependency of **Enniatin C** on the p53 tumor suppressor pathway remains a critical validation step for drug development.

This guide provides a rigorous experimental framework to determine whether **Enniatin C** induces cell death via p53-dependent DNA damage signaling or p53-independent mitochondrial destabilization. By using isogenic HCT116 p53+/+ (Wild Type) and HCT116 p53-/- (Knockout) cell lines, researchers can decouple cytostatic effects (cell cycle arrest) from cytotoxic effects (apoptosis), a distinction vital for predicting drug efficacy in resistant, p53-mutant tumors.

Mechanistic Hypothesis & Logic

The prevailing model for Enniatins suggests a dual mechanism of action. To validate **Enniatin C**, we must test the following hypothesis:

- Primary Mode (Cytotoxicity): **Enniatin C** acts as an ionophore, facilitating cation transport (, ,) across the inner mitochondrial membrane. This causes depolarization, ROS generation, and intrinsic apoptosis, theoretically independent of p53.
- Secondary Mode (Cytostaticity): Cellular stress triggers a p53 response, leading to p21 upregulation and G0/G1 cell cycle arrest, which is p53-dependent.

Mechanistic Pathway Diagram

The following diagram illustrates the bifurcated signaling pathway you are testing.

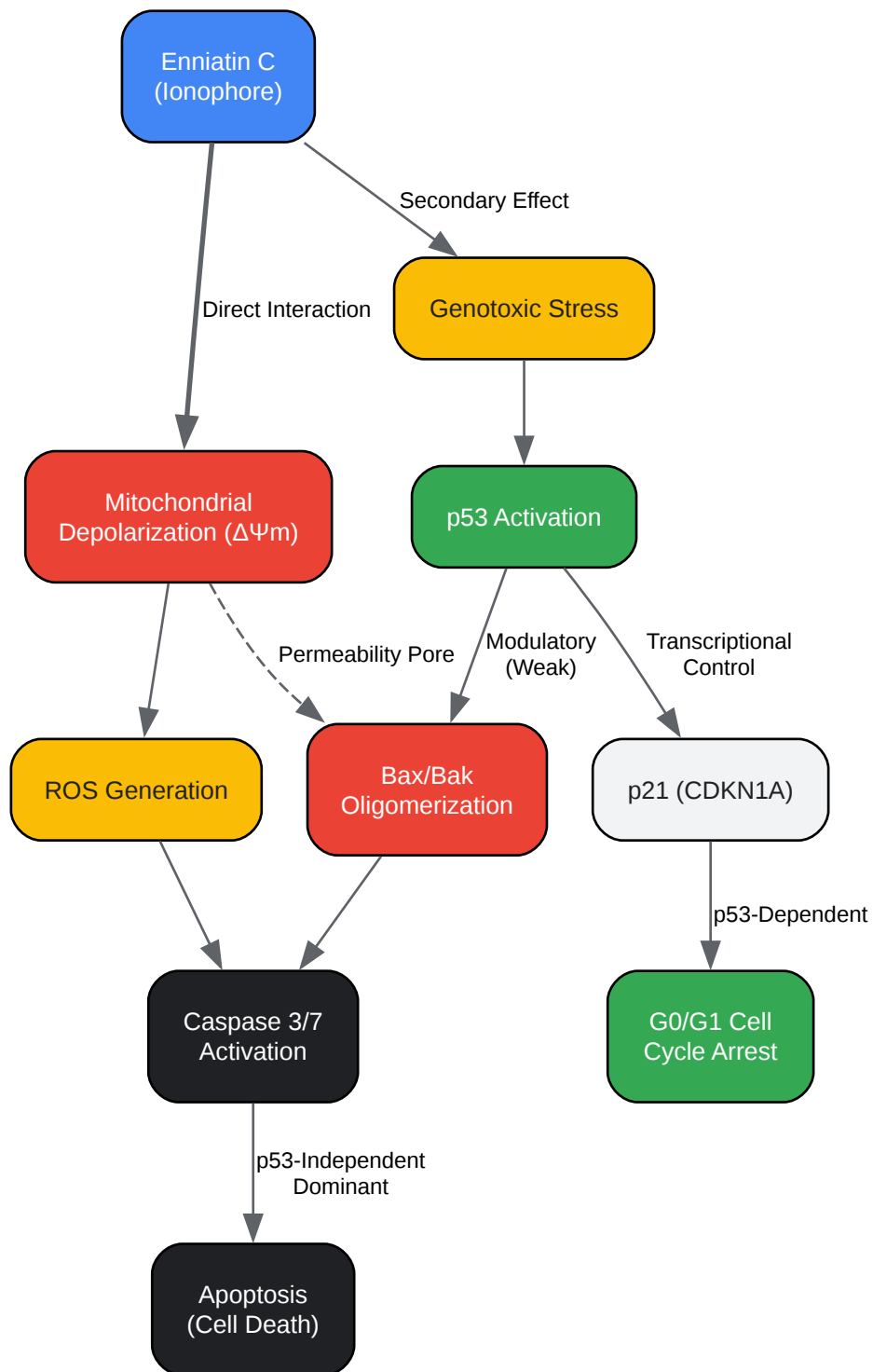

[Click to download full resolution via product page](#)

Caption: Figure 1: Proposed Mechanism of Action. **Enniatin C** drives apoptosis primarily through mitochondrial depolarization (p53-independent), while cell cycle arrest relies on the p53-p21 axis.

Comparative Model System

To confirm this mechanism, you must compare the "Delta" (

) in response between the two cell lines.

Feature	HCT116 p53+/+ (WT)	HCT116 p53-/- (KO)	Experimental Purpose
p53 Status	Functional Wild Type	Homozygous Deletion	Controls for p53-mediated signaling.[1][2][3][4]
Apoptosis Sensitivity	High	High (Hypothesis)	Proves mitochondrial toxicity is direct.
Cell Cycle Arrest	Strong G0/G1 Block	Weak/Absent	Proves arrest is p53-mediated.
p21 Expression	Inducible	Absent/Low	Validates pathway integrity.

Reference Compounds:

- Enniatin B (ENN B): Structural analog and positive control for ionophoric activity.
- Doxorubicin (DOX): Positive control for p53-dependent apoptosis (Expect significant resistance in p53-/- cells).

Experimental Protocols & Validation

Experiment A: Differential Cytotoxicity Assay (IC50 Determination)

Objective: Determine if cell death is dependent on p53. Method: CCK-8 or MTT Assay.

- Seeding: Plate HCT116 WT and HCT116 p53-/- cells at
 cells/well in 96-well plates. Allow 24h attachment.
- Treatment: Treat with **Enniatin C** (0.1, 0.5, 1, 5, 10, 25

).

- Control 1: Enniatin B (Same concentrations).

- Control 2: Doxorubicin (0.01 - 10

).

- Vehicle: DMSO (0.1% final).

- Incubation: 24h and 48h.
- Readout: Add CCK-8 reagent, incubate 2h, read OD at 450nm.
- Analysis: Calculate IC50 using non-linear regression (GraphPad Prism).

Validation Criteria:

- **Enniatin C:** If IC50 is similar (Ratio WT/KO 1.0), cytotoxicity is p53-independent.
- Doxorubicin: IC50 should be significantly higher in p53^{-/-} cells (Ratio WT/KO < 0.5), validating the KO model.

Experiment B: Cell Cycle Analysis (Flow Cytometry)

Objective: Confirm if **Enniatin C**-induced growth arrest requires p53.

- Treatment: Treat both lines with **Enniatin C** at IC50 concentration for 24h.
- Fixation: Harvest cells, wash with PBS, fix in 70% ice-cold ethanol overnight at -20°C.
- Staining: Wash ethanol, resuspend in PBS containing Propidium Iodide (50) and RNase A (100). Incubate 30 min at 37°C.
- Acquisition: Analyze >10,000 events on a Flow Cytometer (FL2 channel).

- Analysis: Use ModFit LT or FlowJo to calculate % cells in G0/G1, S, and G2/M phases.

Expected Result:

- WT Cells: Significant accumulation in G0/G1 phase.[1]
- KO Cells: Reduced or absent G0/G1 arrest; potential accumulation in S-phase or direct sub-G1 (apoptosis) without arrest.

Experiment C: Immunoblotting (Western Blot)

Objective: Visualize the molecular "switch" between arrest and death.

Target Proteins:

- p53: Check for stabilization/upregulation (WT only).
- p21 (WAF1/CIP1): The effector of arrest (High in WT, Low/Absent in KO).
- Cleaved PARP / Caspase-3: Markers of apoptosis (Expect in BOTH WT and KO).
- Bax: Pro-apoptotic pore former (Check for expression in both).

Protocol Workflow:

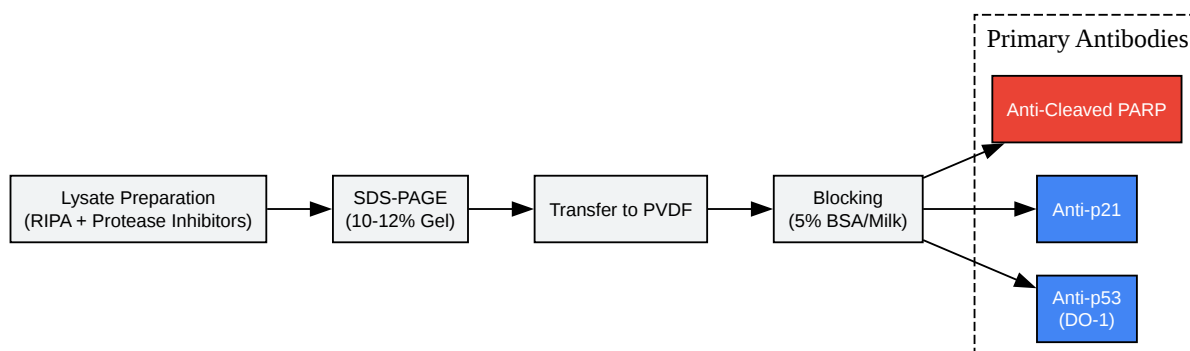

[Click to download full resolution via product page](#)

Caption: Figure 2: Immunoblotting Workflow. Parallel probing for arrest markers (p53/p21) and death markers (PARP).[2]

Data Interpretation & Comparison Guide

Use this table to interpret your experimental results.

Readout	Result in p53+/+ (WT)	Result in p53-/- (KO)	Interpretation
IC50 (Cytotoxicity)	(Example)	(Similar)	p53-Independent Killing. Confirms ionophore-driven mitochondrial toxicity.
Cell Cycle	G0/G1 Arrest (>60%)	No distinct arrest	p53-Dependent Cytostaticity. Enniatin C triggers p53-mediated checkpoints.
p53 Protein	High Expression	Not Detected	Validates model system.
p21 Protein	High Expression	Low/Absent	Confirms p53-p21 axis activation in WT.[1]
Cleaved PARP	Present	Present	Apoptosis occurs regardless of p53 status.

Critical Analysis

If **Enniatin C** fails to kill p53-/- cells (i.e., IC50 is much higher in KO), your hypothesis is incorrect, and the drug acts primarily through DNA damage signaling (like Doxorubicin). However, based on Enniatin B literature, you should expect equipotent cytotoxicity in both lines, which is a highly desirable trait for treating refractory, p53-mutated cancers.

References

- Dornetshuber, R., et al. (2007). Enniatin exerts p53-dependent cytostatic and p53-independent cytotoxic activities against human cancer cells.[2][3][5] *Chemical Research in Toxicology*.
- Wätjen, W., et al. (2009). Enniatins A1, B and B1 from *Fusarium tricinctum* induce apoptosis in H4IIE hepatoma cells accompanied by disruption of mitochondrial membrane potential. *Toxicology*.
- Bunz, F., et al. (1998). Requirement for p53 and p21 to sustain G2 arrest after DNA damage. *Science*.
- Kooti, W., et al. (2017). Therapeutic and pharmacological potential of Enniatins: A review. *Asian Pacific Journal of Tropical Biomedicine*.

Need Custom Synthesis?

BenchChem offers custom synthesis for rare earth carbides and specific isotopic labeling.

Email: info@benchchem.com or [Request Quote Online](#).

Sources

- 1. Enniatin exerts p53-dependent cytostatic and p53-independent cytotoxic activities against human cancer cells - PubMed [pubmed.ncbi.nlm.nih.gov]
- 2. [researchgate.net](https://www.researchgate.net) [[researchgate.net](https://www.researchgate.net)]
- 3. pubs.acs.org [pubs.acs.org]
- 4. Comparable radiation sensitivity in p53 wild-type and p53 deficient tumor cells associated with different cell death modalities - PMC [[pmc.ncbi.nlm.nih.gov](https://pubmed.ncbi.nlm.nih.gov)]
- 5. Revisiting the enniatins: a review of their isolation, biosynthesis, structure determination, and biological activities - PMC [[pmc.ncbi.nlm.nih.gov](https://pubmed.ncbi.nlm.nih.gov)]
- To cite this document: BenchChem. [Comparative Guide: Validating the Enniatin C Mechanism via p53 Knockout Models]. BenchChem, [2026]. [Online PDF]. Available at: [<https://www.benchchem.com/product/b1671337/docs#comparative-guide-validating-the-enniain-c-mechanism-via-p53-knockout-models>]

Disclaimer & Data Validity:

The information provided in this document is for Research Use Only (RUO) and is strictly not intended for diagnostic or therapeutic procedures. While BenchChem strives to provide accurate protocols, we make no warranties, express or implied, regarding the fitness of this product for every specific experimental setup.

Technical Support: The protocols provided are for reference purposes. Unsure if this reagent suits your experiment?

Need Industrial/Bulk Grade? [Request Custom Synthesis Quote](#)

BenchChem

Our mission is to be the trusted global source of essential and advanced chemicals, empowering scientists and researchers to drive progress in science and industry.

Contact

Address: 3281 E Guasti Rd
Ontario, CA 91761, United States
Phone: (601) 213-4426
Email: info@benchchem.com

[Contact our Ph.D. Support Team for a compatibility check](#)