

Cell line specific responses to Gne-477 treatment

Author: BenchChem Technical Support Team. **Date:** December 2025

Compound of Interest

Compound Name: Gne-477

Cat. No.: B1671977

[Get Quote](#)

GNE-477 Technical Support Center

This technical support center provides researchers, scientists, and drug development professionals with comprehensive troubleshooting guides and frequently asked questions (FAQs) for experiments involving the dual PI3K/mTOR inhibitor, **GNE-477**.

Frequently Asked Questions (FAQs)

Q1: What is **GNE-477** and what is its mechanism of action?

GNE-477 is a potent and efficacious dual inhibitor of Phosphoinositide 3-kinase (PI3K) and mammalian Target of Rapamycin (mTOR).[1][2][3][4] It functions by blocking the PI3K/AKT/mTOR signaling pathway, which is a critical pathway for regulating cell growth, proliferation, survival, and metabolism.[5][6] Dysregulation of this pathway is a common feature in many types of cancer.[5][6] **GNE-477** has been shown to inhibit the phosphorylation of key downstream effectors of PI3K and mTOR, such as Akt, p70S6K1, and S6, leading to the suppression of tumor cell growth.[5][7][8]

Q2: In which cancer cell lines has **GNE-477** shown activity?

GNE-477 has demonstrated anti-cancer activity in a variety of cell lines, including:

- Glioblastoma: U87 and U251 cells.[5][6]
- Renal Cell Carcinoma (RCC): Primary human RCC cells.[7][8][9]

- Prostate Cancer: PC3 cells.[1][2][10]
- Breast Cancer: MCF-7.1 cells.[1][10]
- Osteosarcoma: MG-63, U2OS, and 143B cells.[11]

Q3: What are the known cellular responses to **GNE-477** treatment?

Treatment with **GNE-477** has been shown to induce several key cellular responses in sensitive cancer cell lines:

- Inhibition of Proliferation: **GNE-477** effectively suppresses the proliferation of cancer cells.[5][9]
- Apoptosis Induction: The compound induces programmed cell death (apoptosis).[5][7][9]
- Cell Cycle Arrest: **GNE-477** causes cell cycle arrest, primarily in the G0/G1 phase.[5][11]
- Inhibition of Migration and Invasion: It has been observed to reduce the migratory and invasive capabilities of cancer cells.[5][6]

Q4: What is the solubility and stability of **GNE-477**?

GNE-477 is soluble in DMSO.[1][3] For long-term storage, it is recommended to store the solid compound at -20°C, where it is stable for at least four years.[1] Stock solutions in DMSO can be stored at -80°C for up to two years.[10] It is insoluble in water and ethanol.

Troubleshooting Guides

Cell Viability Assays (e.g., CCK-8, MTT)

Problem	Possible Cause(s)	Suggested Solution(s)
High variability between replicate wells	- Uneven cell seeding.- Pipetting errors.- Edge effects in the microplate.	- Ensure a homogenous single-cell suspension before seeding.- Use calibrated pipettes and proper pipetting technique.- Avoid using the outer wells of the plate or fill them with sterile PBS or media.
Low signal or no dose-dependent effect	- GNE-477 concentration is too low.- Incubation time is too short.- Cell line is resistant to GNE-477.- GNE-477 precipitated out of solution.	- Test a wider range of GNE-477 concentrations.- Increase the incubation time (e.g., 48-72 hours).- Verify the sensitivity of your cell line to PI3K/mTOR inhibitors.- Ensure GNE-477 is fully dissolved in DMSO before diluting in culture medium. Avoid repeated freeze-thaw cycles of the stock solution.
Unexpected increase in viability at high concentrations	- Compound precipitation at high concentrations can interfere with absorbance readings.- Off-target effects.	- Visually inspect wells for precipitation under a microscope.- Test a different viability assay based on a different principle (e.g., ATP-based assay).- Review literature for potential off-target effects of GNE-477.
Inconsistent results with different batches of GNE-477	- Variation in compound purity or activity.	- Purchase GNE-477 from a reputable supplier and obtain a certificate of analysis.- Test each new batch to confirm its activity before use in large-scale experiments.

Apoptosis Assays (e.g., Annexin V/PI Staining)

Problem	Possible Cause(s)	Suggested Solution(s)
High percentage of necrotic cells (Annexin V+/PI+) even at low GNE-477 concentrations	- GNE-477 may be causing necrosis at the tested concentrations.- Harsh cell handling during the staining procedure.	- Perform a time-course experiment to detect early apoptosis.- Handle cells gently during harvesting and washing steps. Avoid vigorous vortexing.
No significant increase in apoptotic cells	- Insufficient GNE-477 concentration or incubation time.- Cell line is resistant to apoptosis induction by GNE-477.- Problems with the staining protocol or reagents.	- Increase the concentration of GNE-477 and/or the incubation time.- Confirm apoptosis induction with a positive control (e.g., staurosporine).- Check the expiration dates of Annexin V and PI, and ensure proper storage.
High background fluorescence	- Incomplete washing of unbound antibodies.- Autofluorescence of the cells or GNE-477.	- Increase the number of washing steps.- Include an unstained cell control to assess autofluorescence. If GNE-477 is suspected to be fluorescent, analyze a sample of media with GNE-477 alone.

Cell Cycle Analysis (Flow Cytometry)

Problem	Possible Cause(s)	Suggested Solution(s)
Broad G1 and G2/M peaks	- Cell clumping.- Improper fixation.	- Ensure a single-cell suspension before fixation by passing through a cell strainer.- Use cold ethanol and add it dropwise while vortexing to prevent cell aggregation.
No clear G0/G1 arrest	- The cell line may not arrest in G0/G1 in response to GNE-477.- Suboptimal GNE-477 concentration or treatment duration.	- Analyze the expression of cell cycle regulatory proteins (e.g., cyclins, CDKs) by Western blot.- Perform a time-course and dose-response experiment.
Sub-G1 peak is present but no Annexin V positive cells were detected	- Different sensitivities of the assays.- The sub-G1 peak may represent cellular debris.	- Gate carefully on the cell population to exclude debris.- Correlate results with other apoptosis markers (e.g., caspase activation).

Western Blot Analysis

Problem	Possible Cause(s)	Suggested Solution(s)
No decrease in p-Akt or p-mTOR levels	- Insufficient GNE-477 concentration or treatment time.- Cells were not properly starved before stimulation (if applicable).- Antibody not working.	- Increase GNE-477 concentration or treatment duration.- If studying growth factor-stimulated phosphorylation, starve cells in serum-free media before treatment.- Use a positive control cell lysate with known pathway activation.
Basal phosphorylation levels are very low	- Cells are not actively proliferating or are in a quiescent state.	- Ensure cells are in the logarithmic growth phase before treatment.
Variability in protein loading	- Inaccurate protein quantification.- Uneven transfer.	- Use a reliable protein quantification method (e.g., BCA assay).- Normalize to a loading control (e.g., GAPDH, β -actin) that is not affected by GNE-477 treatment.

Quantitative Data

Table 1: IC50 and EC50 Values of **GNE-477** in Various Cancer Cell Lines

Cell Line	Cancer Type	Assay	Value	Reference
U87	Glioblastoma	CCK-8	0.1535 μ M	[5]
U251	Glioblastoma	CCK-8	0.4171 μ M	[5]
Primary RCC	Renal Cell Carcinoma	CCK-8	~10-100 nM	[9]
PC3	Prostate Cancer	CellTiter-Glo	EC50: 174 nM	
MCF-7.1	Breast Cancer	Cell Proliferation	EC50: 143 nM	[1][10]

Experimental Protocols

Cell Viability Assay (CCK-8)

- Seed cells in a 96-well plate at a density of 5,000 cells/well in 100 μ L of complete medium.
- Incubate the plate for 24 hours to allow for cell attachment.
- Prepare serial dilutions of **GNE-477** in complete medium.
- Remove the medium from the wells and add 100 μ L of the **GNE-477** dilutions. Include a vehicle control (DMSO) at the same final concentration as in the drug-treated wells.
- Incubate the plate for the desired time period (e.g., 24, 48, or 72 hours).
- Add 10 μ L of CCK-8 solution to each well.
- Incubate the plate for 1-4 hours at 37°C.
- Measure the absorbance at 450 nm using a microplate reader.
- Calculate cell viability as a percentage of the vehicle-treated control.

Apoptosis Assay (Annexin V-FITC/PI Staining)

- Seed cells in a 6-well plate and treat with various concentrations of **GNE-477** for the desired time.
- Harvest both adherent and floating cells.
- Wash the cells twice with cold PBS.
- Resuspend the cells in 1X Binding Buffer at a concentration of 1×10^6 cells/mL.
- Transfer 100 μ L of the cell suspension to a flow cytometry tube.
- Add 5 μ L of FITC Annexin V and 5 μ L of Propidium Iodide.
- Gently vortex the cells and incubate for 15 minutes at room temperature in the dark.

- Add 400 μ L of 1X Binding Buffer to each tube.
- Analyze the samples by flow cytometry within one hour.

Cell Cycle Analysis (Propidium Iodide Staining)

- Seed cells and treat with **GNE-477** as for the apoptosis assay.
- Harvest the cells and wash with PBS.
- Fix the cells by adding them dropwise to ice-cold 70% ethanol while gently vortexing.
- Incubate the cells at -20°C for at least 2 hours.
- Wash the cells with PBS to remove the ethanol.
- Resuspend the cell pellet in a staining solution containing Propidium Iodide and RNase A.
- Incubate for 30 minutes at room temperature in the dark.
- Analyze the samples by flow cytometry.

Western Blotting for p-Akt and p-mTOR

- Lyse **GNE-477**-treated and control cells in RIPA buffer containing protease and phosphatase inhibitors.
- Determine the protein concentration of the lysates using a BCA assay.
- Denature equal amounts of protein by boiling in Laemmli sample buffer.
- Separate the proteins by SDS-PAGE and transfer them to a PVDF membrane.
- Block the membrane with 5% non-fat dry milk or BSA in TBST for 1 hour at room temperature.
- Incubate the membrane with primary antibodies against p-Akt (Ser473), total Akt, p-mTOR (Ser2448), total mTOR, and a loading control (e.g., GAPDH) overnight at 4°C .

- Wash the membrane with TBST and incubate with the appropriate HRP-conjugated secondary antibody for 1 hour at room temperature.
- Wash the membrane again and detect the signal using an enhanced chemiluminescence (ECL) substrate.

Signaling Pathways and Experimental Workflows

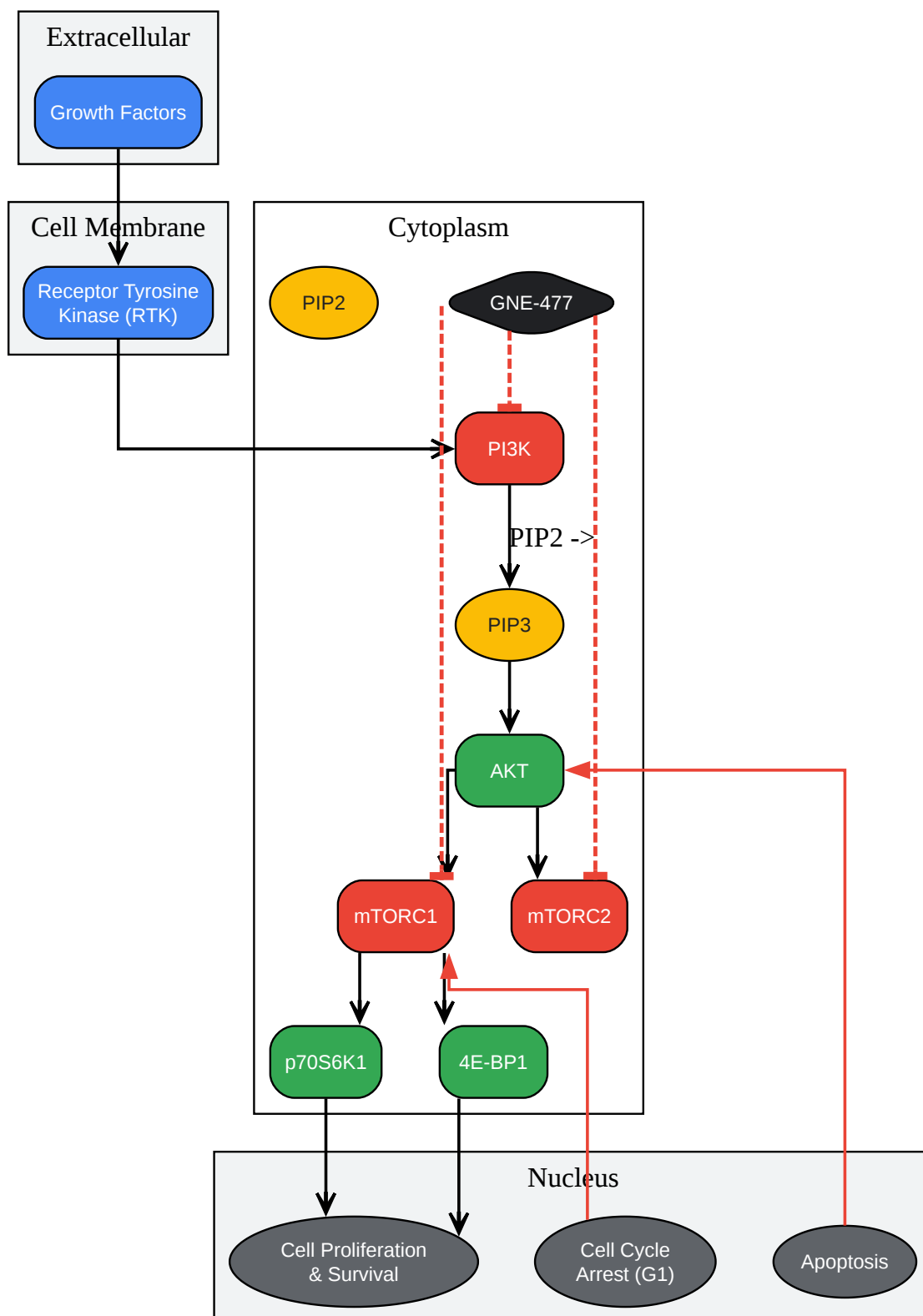

[Click to download full resolution via product page](#)

Caption: **GNE-477** inhibits the PI3K/AKT/mTOR signaling pathway.

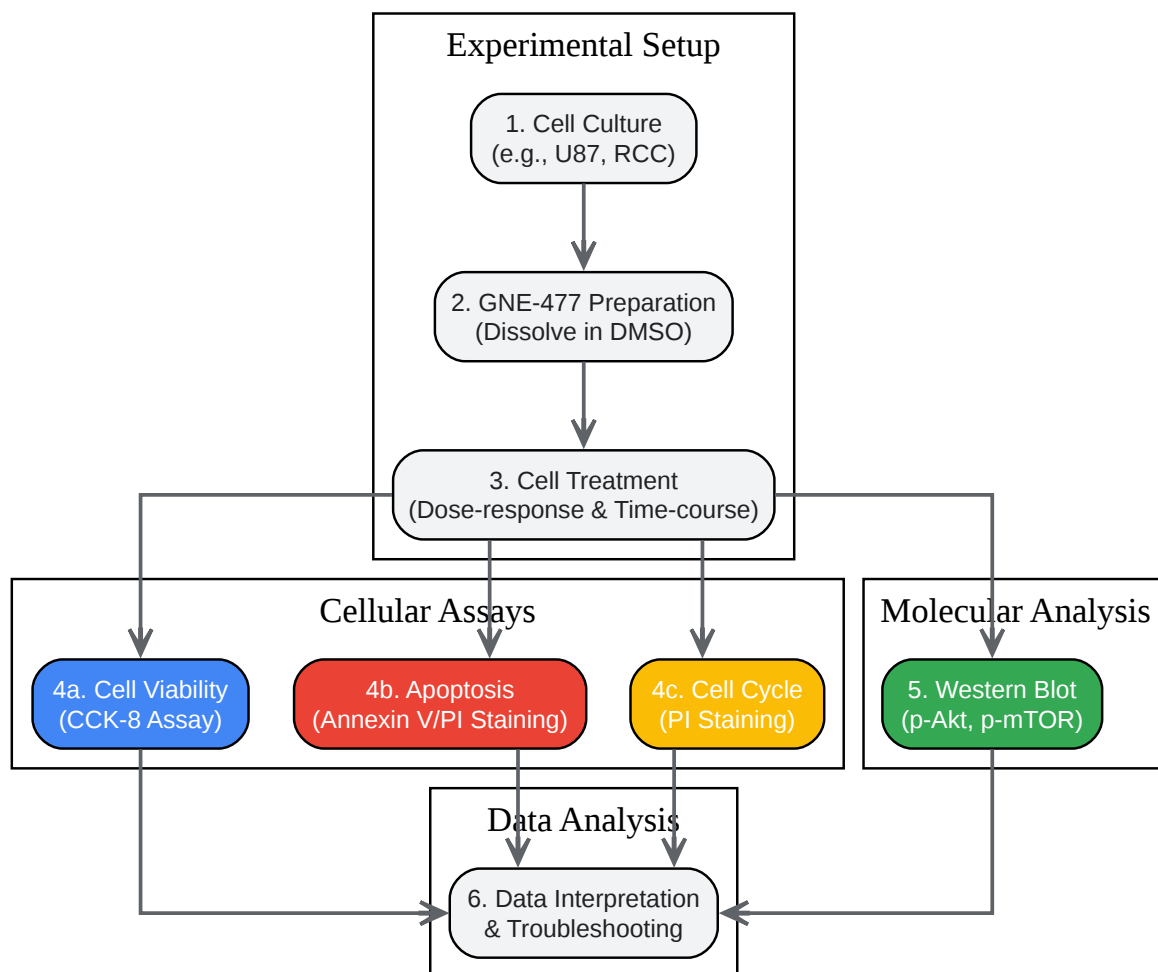

[Click to download full resolution via product page](#)

Caption: A typical experimental workflow for studying **GNE-477** effects.

Need Custom Synthesis?

BenchChem offers custom synthesis for rare earth carbides and specific isotopic labeling.

Email: info@benchchem.com or [Request Quote Online](#).

References

- 1. caymanchem.com [caymanchem.com]

- 2. GNE 477|PI3K/mTOR inhibitor|DC Chemicals [dcchemicals.com]
- 3. selleckchem.com [selleckchem.com]
- 4. medkoo.com [medkoo.com]
- 5. The New PI3K/mTOR Inhibitor GNE-477 Inhibits the Malignant Behavior of Human Glioblastoma Cells - PMC [pmc.ncbi.nlm.nih.gov]
- 6. Frontiers | The New PI3K/mTOR Inhibitor GNE-477 Inhibits the Malignant Behavior of Human Glioblastoma Cells [frontiersin.org]
- 7. PI3K-Akt-mTOR inhibition by GNE-477 inhibits renal cell carcinoma cell growth in vitro and in vivo - PMC [pmc.ncbi.nlm.nih.gov]
- 8. PI3K-Akt-mTOR inhibition by GNE-477 inhibits renal cell carcinoma cell growth in vitro and in vivo - PubMed [pubmed.ncbi.nlm.nih.gov]
- 9. PI3K-Akt-mTOR inhibition by GNE-477 inhibits renal cell carcinoma cell growth in vitro and in vivo | Aging [aging-us.com]
- 10. medchemexpress.com [medchemexpress.com]
- 11. Therapeutic impacts of GNE-477-loaded H₂O₂ stimulus-responsive dodecanoic acid-phenylborate ester-dextran polymeric micelles on osteosarcoma - PMC [pmc.ncbi.nlm.nih.gov]
- To cite this document: BenchChem. [Cell line specific responses to Gne-477 treatment]. BenchChem, [2025]. [Online PDF]. Available at: [https://www.benchchem.com/product/b1671977#cell-line-specific-responses-to-gne-477-treatment]

Disclaimer & Data Validity:

The information provided in this document is for Research Use Only (RUO) and is strictly not intended for diagnostic or therapeutic procedures. While BenchChem strives to provide accurate protocols, we make no warranties, express or implied, regarding the fitness of this product for every specific experimental setup.

Technical Support: The protocols provided are for reference purposes. Unsure if this reagent suits your experiment? [[Contact our Ph.D. Support Team for a compatibility check](#)]

Need Industrial/Bulk Grade? [Request Custom Synthesis Quote](#)

BenchChem

Our mission is to be the trusted global source of essential and advanced chemicals, empowering scientists and researchers to drive progress in science and industry.

Contact

Address: 3281 E Guasti Rd

Ontario, CA 91761, United States

Phone: (601) 213-4426

Email: info@benchchem.com