

Application Notes and Protocols for Intraperitoneal Injection of DR-4004 in Mice

Author: BenchChem Technical Support Team. **Date:** December 2025

Compound of Interest

Compound Name: DR-4004

Cat. No.: B1670936

[Get Quote](#)

For Researchers, Scientists, and Drug Development Professionals

Introduction

DR-4004 is a research compound identified as a putative antagonist of the 5-hydroxytryptamine-7 (5-HT7) receptor, which also exhibits functional activity at the dopamine D2 receptor.[1] This dual activity makes it a compound of interest for investigating the roles of these two neurotransmitter systems in various physiological and pathological processes. These application notes provide a summary of the known in vivo effects of **DR-4004** and detailed protocols for its intraperitoneal (i.p.) administration in mice for preclinical research.

Mechanism of Action & Signaling Pathways

DR-4004's pharmacological profile is characterized by its interaction with two distinct G-protein coupled receptors:

- **5-HT7 Receptor Antagonism:** The 5-HT7 receptor is primarily coupled to Gs proteins. Canonical signaling involves the activation of adenylyl cyclase, leading to an increase in intracellular cyclic adenosine monophosphate (cAMP) and subsequent activation of Protein Kinase A (PKA).[2] PKA can then phosphorylate various downstream targets, influencing gene transcription and cellular function. A non-canonical pathway involves coupling to G12 proteins, which can activate Rho GTPases and influence the actin cytoskeleton.[2]

- Dopamine D2 Receptor Activity: The dopamine D2 receptor is predominantly coupled to Gi/o proteins.[3][4] Activation of this receptor inhibits adenylyl cyclase, resulting in a decrease in intracellular cAMP levels.[4] D2 receptor signaling can also modulate intracellular calcium levels and potassium channel activity.[3]

The interplay of these two opposing signaling cascades upon administration of **DR-4004** is a key area for investigation.

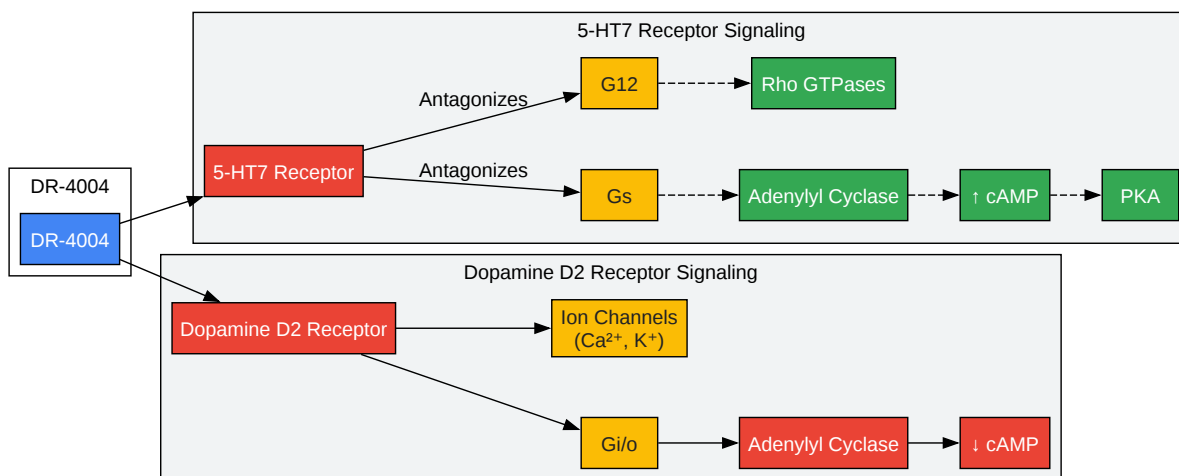

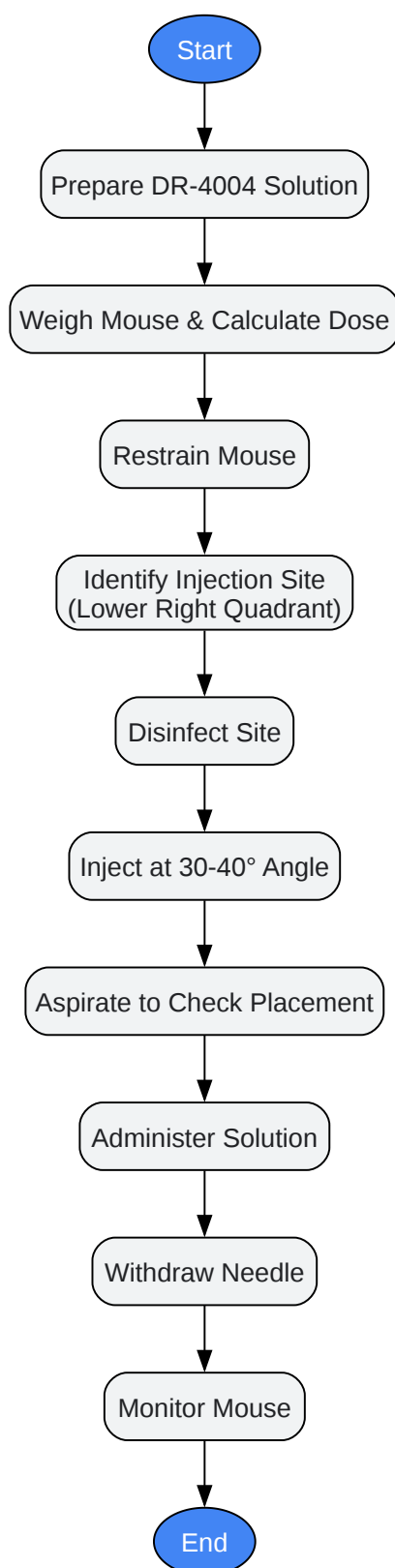

[Click to download full resolution via product page](#)

Need Custom Synthesis?

BenchChem offers custom synthesis for rare earth carbides and specific isotopic labeling.

Email: info@benchchem.com or [Request Quote Online](#).

References

- 1. DR4004, a putative 5-HT(7) receptor antagonist, also has functional activity at the dopamine D2 receptor - PubMed [pubmed.ncbi.nlm.nih.gov]
- 2. Cellular mechanisms of the 5-HT7 receptor-mediated signaling - PMC [pmc.ncbi.nlm.nih.gov]
- 3. researchgate.net [researchgate.net]
- 4. D2 (Dopamine) Receptors Mnemonic for USMLE [pixorize.com]
- To cite this document: BenchChem. [Application Notes and Protocols for Intraperitoneal Injection of DR-4004 in Mice]. BenchChem, [2025]. [Online PDF]. Available at: [https://www.benchchem.com/product/b1670936#intraperitoneal-injection-of-dr-4004-in-mice]

Disclaimer & Data Validity:

The information provided in this document is for Research Use Only (RUO) and is strictly not intended for diagnostic or therapeutic procedures. While BenchChem strives to provide accurate protocols, we make no warranties, express or implied, regarding the fitness of this product for every specific experimental setup.

Technical Support: The protocols provided are for reference purposes. Unsure if this reagent suits your experiment? [[Contact our Ph.D. Support Team for a compatibility check](#)]

Need Industrial/Bulk Grade? [Request Custom Synthesis Quote](#)

BenchChem

Our mission is to be the trusted global source of essential and advanced chemicals, empowering scientists and researchers to drive progress in science and industry.

Contact

Address: 3281 E Guasti Rd

Ontario, CA 91761, United States

Phone: (601) 213-4426

Email: info@benchchem.com