

# Application Notes and Protocols for Dup 747 in Rodent Models

**Author:** BenchChem Technical Support Team. **Date:** April 2026

## Compound of Interest

Compound Name:	Dup 747
CAS No.:	142515-44-4
Cat. No.:	B1670993

[Get Quote](#)

For Researchers, Scientists, and Drug Development Professionals

## Introduction

**Dup 747**, a potent and selective kappa-opioid receptor agonist, has been investigated for its analgesic properties. These application notes provide a summary of available data on its dosage and administration in rodent models. It is important to note that publicly available information on **Dup 747** is limited, particularly concerning its use in mice and comprehensive toxicology data. Therefore, the following protocols and data are primarily based on studies conducted in rats. Researchers should consider this a starting point and conduct thorough dose-finding and safety studies for their specific experimental models and conditions.

## Data Presentation: Dosage in Rodent Models

The following tables summarize the available quantitative data for **Dup 747** administration in rats.

Table 1: **Dup 747** Dosage and Efficacy in Rats

Administration Route	Dose Range (mg/kg)	ED50 (mg/kg)	Observed Effect	Animal Model	Reference
Subcutaneous (SC)	1.0 - 30	Not Established	Little to no spiradoline-appropriate lever selection	Sprague-Dawley Rats	[1]
Intraperitoneal (IP)	1.0 - 30	5.9	Partial generalization from spiradoline	Sprague-Dawley Rats	[1]
Oral (PO)	1.0 - 30	59	Partial generalization from spiradoline	Sprague-Dawley Rats	[1]

Note: The efficacy of **Dup 747** appears to be route-dependent, with subcutaneous administration showing limited activity compared to intraperitoneal and oral routes in the cited study. This suggests that a metabolite of **Dup 747** may be responsible for the observed kappa-opioid agonist effects[1].

## Mechanism of Action: Kappa-Opioid Receptor Signaling

**Dup 747** exerts its effects by acting as an agonist at the kappa-opioid receptor (KOR), a G-protein coupled receptor (GPCR). The binding of **Dup 747** to KOR initiates downstream signaling cascades through two primary pathways: the G-protein pathway and the  $\beta$ -arrestin pathway.

### Signaling Pathway Diagrams

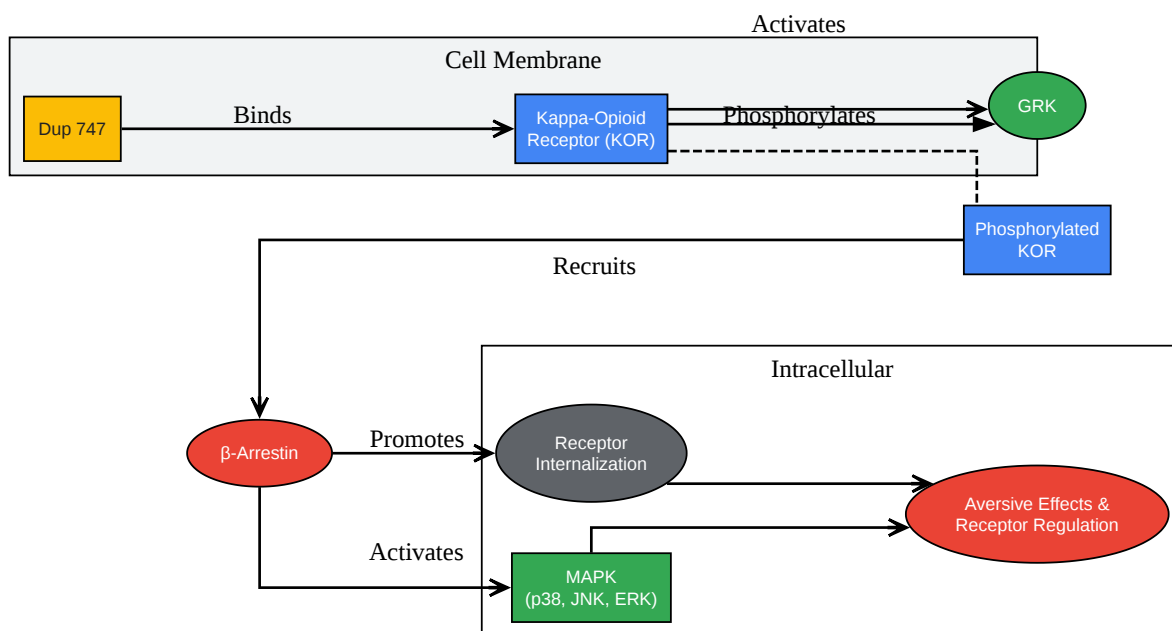
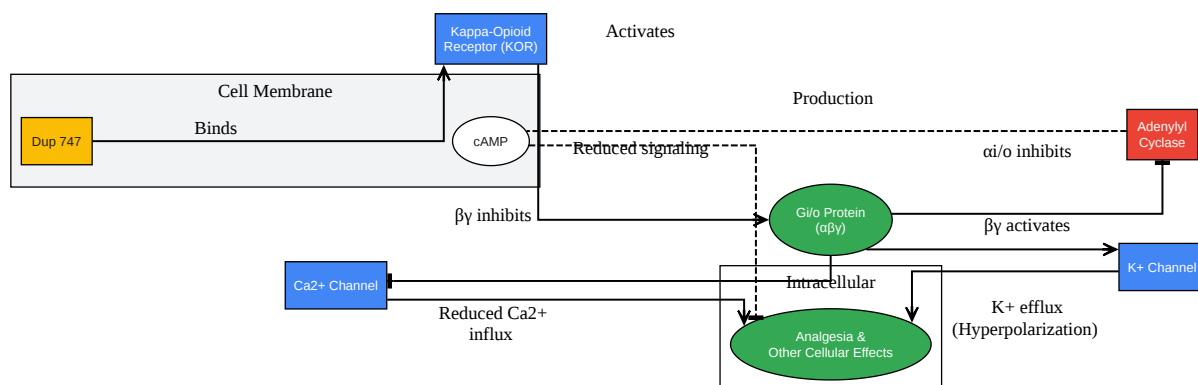

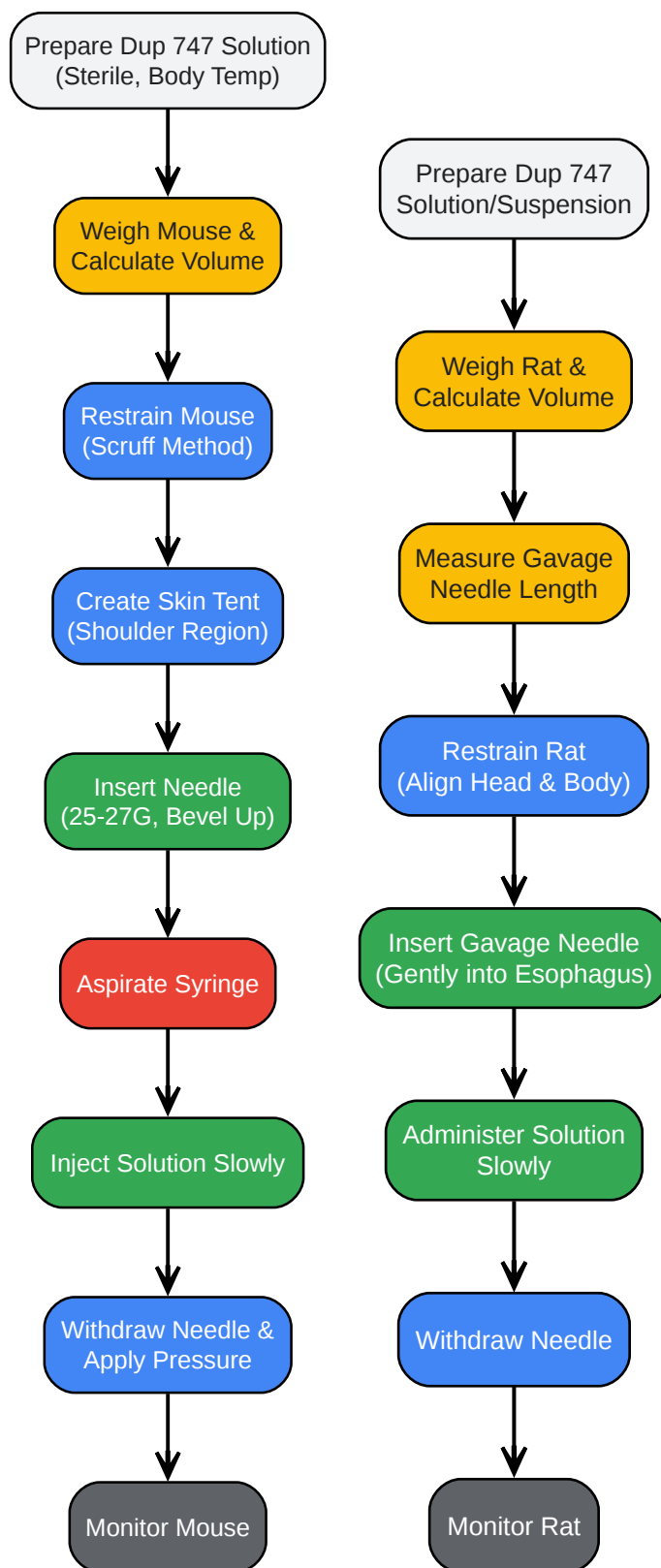

[Click to download full resolution via product page](#)

**Need Custom Synthesis?**

BenchChem offers custom synthesis for rare earth carbides and specific isotopic labeling.

Email: [info@benchchem.com](mailto:info@benchchem.com) or [Request Quote Online](#).

## References

- [1. mdpi.com \[mdpi.com\]](https://www.mdpi.com)
- To cite this document: BenchChem. [Application Notes and Protocols for Dup 747 in Rodent Models]. BenchChem, [2026]. [Online PDF]. Available at: [\[https://www.benchchem.com/product/b1670993/docs#application-notes-and-protocols-for-dup-747-in-rodent-models\]](https://www.benchchem.com/product/b1670993/docs#application-notes-and-protocols-for-dup-747-in-rodent-models)

---

**Disclaimer & Data Validity:**

The information provided in this document is for Research Use Only (RUO) and is strictly not intended for diagnostic or therapeutic procedures. While BenchChem strives to provide accurate protocols, we make no warranties, express or implied, regarding the fitness of this product for every specific experimental setup.

**Technical Support:** The protocols provided are for reference purposes. Unsure if this reagent suits your experiment?

**Need Industrial/Bulk Grade?** [Request Custom Synthesis Quote](#)

## BenchChem

Our mission is to be the trusted global source of essential and advanced chemicals, empowering scientists and researchers to drive progress in science and industry.

### Contact

Address: 3281 E Guasti Rd  
Ontario, CA 91761, United States  
Phone: (601) 213-4426  
Email: [info@benchchem.com](mailto:info@benchchem.com)

Contact our Ph.D. Support Team for a compatibility check