

A Comparative Guide to Ethyl Diazoacetate and Trimethylsilyldiazomethane for Cyclopropanation

Author: BenchChem Technical Support Team. **Date:** December 2025

Compound of Interest

Compound Name: *Ethyl diazoacetate*

Cat. No.: *B1670405*

[Get Quote](#)

The construction of cyclopropane rings is a fundamental transformation in organic synthesis, owing to the prevalence of this motif in natural products, pharmaceuticals, and agrochemicals. [1] Among the various methods available for cyclopropanation, the reaction of an alkene with a carbene or carbenoid precursor is one of the most powerful. **Ethyl diazoacetate** (EDA) and trimethylsilyldiazomethane (TMSD) are two widely used diazo compounds for this purpose. This guide provides a detailed comparison of their performance, safety, and handling, supported by experimental data to aid researchers in selecting the appropriate reagent for their specific needs.

Reaction Mechanism: The Metal Carbene Pathway

Both **ethyl diazoacetate** and trimethylsilyldiazomethane typically require a transition metal catalyst to facilitate cyclopropanation. The generally accepted mechanism involves the reaction of the diazo compound with a metal complex to form a highly reactive metal-carbene intermediate. This intermediate then reacts with an alkene to transfer the carbene moiety, generating the cyclopropane ring and regenerating the catalyst.[2][3]

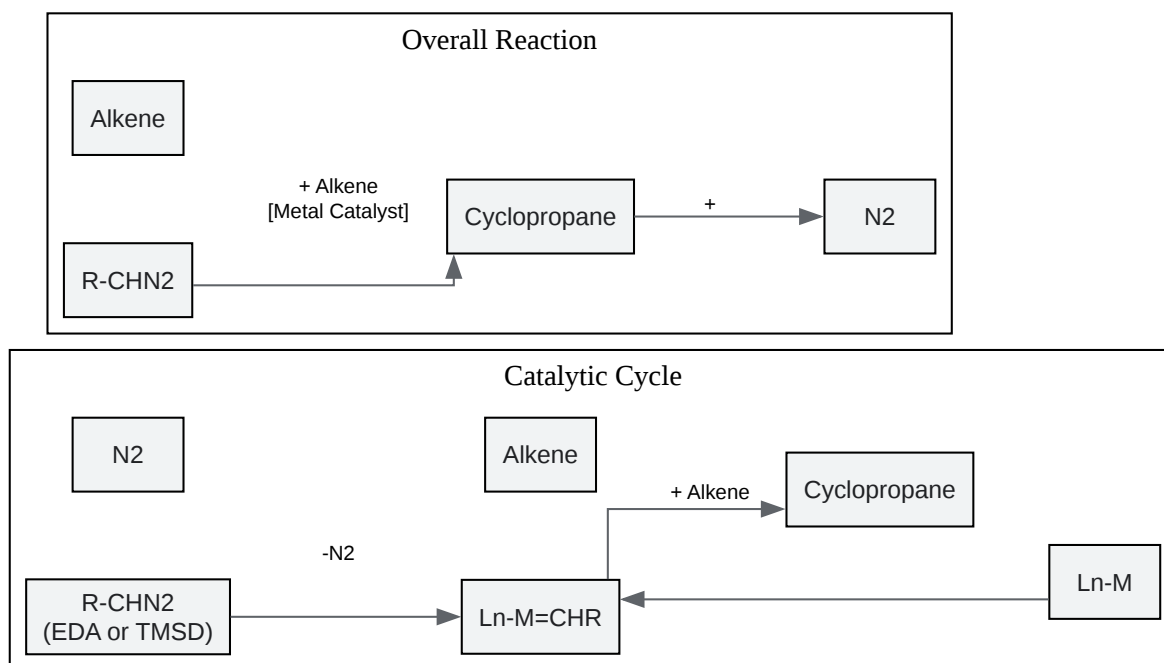

[Click to download full resolution via product page](#)

Caption: General mechanism for metal-catalyzed cyclopropanation.

Performance Comparison

The choice between EDA and TMSD often depends on the specific substrate, the desired stereochemical outcome, and the reaction conditions. The following table summarizes key performance metrics based on published experimental data.

Feature	Ethyl Diazoacetate (EDA)	Trimethylsilyldiazomethane (TMSD)
Typical Catalysts	Rhodium (e.g., Rh ₂ (OAc) ₄), Copper (e.g., Cu(acac) ₂ , Cu(OTf) ₂), Ruthenium (e.g., Ru(II)-Pheox), Palladium.[4][5][6][7][8]	Palladium (e.g., Pd(OAc) ₂), Iron (e.g., (TTP)Fe).[9][10][11]
Reactivity	Highly versatile, reacting with a wide range of electron-rich and electron-deficient alkenes.[6][7][12] Can sometimes lead to side reactions like dimerization to form diethyl fumarate and maleate.[4]	Effective for the cyclopropanation of various alkenes, including specialized substrates like 1,1-diborylalkenes.[9][10][13][14] Can sometimes lead to olefination instead of cyclopropanation.[9][10]
Substrate Scope	Broad scope, including styrenes, dienes, and functionalized allylic derivatives.[4][5][15] Effective for both mono- and disubstituted olefins.[2]	Well-suited for 2-substituted 1,1-diborylalkenes and styrenes.[9][10][11][13][14] The substrate scope includes those with various electronic and steric properties.[16]
Stereoselectivity	Diastereoselectivity (cis/trans) is highly dependent on the catalyst and substrate.[2][4] Chiral catalysts can induce high enantioselectivity (up to 99% ee).[5][15]	Can provide high diastereoselectivity, often favoring the anti conformation between substituents on the cyclopropane ring.[9][10][13][14] High trans/cis ratios (up to 13:1) have been reported.[11]
Typical Yields	Moderate to high yields, ranging from 32% to 97% depending on the substrate and catalyst system.[5][15]	Generally good to excellent yields, with reports of up to 89%.[11]

Experimental Protocols

General Procedure for Pd-Catalyzed Cyclopropanation with Ethyl Diazoacetate[4]

This protocol is a representative example for the cyclopropanation of a 2-substituted 1,3-diene.

- Preparation: In a nitrogen-filled glovebox, add the diene substrate (0.5 mmol, 1.0 equiv) and the palladium precatalyst (e.g., 5 mol%) to a Schlenk flask containing THF (5 mL, 0.1 M).
- Reaction Initiation: At room temperature, add a 15% solution of **ethyl diazoacetate** in toluene (0.75 mmol, 1.5 equiv) to the flask at once.
- Reaction: Stir the reaction mixture at 25 °C for 30 minutes.
- Quenching: Remove the Schlenk flask from the glovebox and quench the reaction by diluting the mixture with THF (5 mL).
- Work-up: Concentrate the crude mixture under reduced pressure.
- Purification: Adsorb the residue onto silica gel and purify by column chromatography to isolate the vinylcyclopropane product.

General Procedure for Pd-Catalyzed Cyclopropanation with (Trimethylsilyl)diazomethane[9][10]

This protocol is representative for the cyclopropanation of 2-substituted 1,1-diborylalkenes.

- Preparation: To a solution of the 1,1-diborylalkene (0.2 mmol) in dry toluene (2.0 mL) under an argon atmosphere, add the palladium catalyst (e.g., Pd(OAc)₂, 5 mol%).
- Reaction Initiation: Add (trimethylsilyl)diazomethane (2.0 M in hexanes, 0.3 mmol, 1.5 equiv) dropwise to the mixture at room temperature.
- Reaction: Stir the reaction mixture at room temperature for the appropriate time (typically monitored by TLC or GC-MS).
- Work-up: Once the reaction is complete, concentrate the mixture under reduced pressure.

- Purification: Purify the residue by column chromatography on silica gel to afford the desired silyl-substituted cyclopropane.

Safety and Handling

Both EDA and TMSD are hazardous reagents that require careful handling in a controlled laboratory environment.

Hazard Category	Ethyl Diazoacetate (EDA)	Trimethylsilyldiazomethane (TMSD)
Toxicity	Toxic and can cause sensitization.[17] Suspected of causing cancer.[18]	Extremely toxic upon inhalation, which can be fatal due to pulmonary edema.[19] [20] Harmful if ingested or absorbed through the skin.[21] Suspected of causing cancer and fertility damage.[19][21]
Explosive Hazard	Potentially explosive, especially when heated or distilled, even under reduced pressure.[17][22] Should not be stored in bulk and is often prepared in situ for large-scale applications.[22]	Considered a less explosive alternative to diazomethane, but still requires careful handling.[19] Can form the more toxic and explosive diazomethane in alcoholic solvents under acidic or basic conditions.[19][21]
Personal Protective Equip.	Wear a lab coat, safety goggles, and appropriate gloves.[23] All operations should be conducted in a well-ventilated fume hood.[17]	Wear a flame-resistant lab coat, double nitrile or neoprene gloves, ANSI-compliant safety goggles, and a face shield.[19] [20]
Handling & Storage	Keep container tightly closed and store in a cool, well-ventilated place, away from heat and ignition sources.[17] [23] Use non-sparking tools. [23]	Must be handled in a fume hood, preferably with a blast shield.[19] Store under an inert atmosphere and keep the container tightly sealed.[19] [20] Avoid temperature extremes and direct sunlight. [20]
Spill & Decontamination	For small spills, absorb with an inert material and dispose of as hazardous waste. For large spills, evacuate the area.	For small spills inside a fume hood, use a spill kit.[21] Contaminated items can be soaked in an acetic acid/water

bath until gas evolution ceases to quench the TMSD.[19]

Waste Disposal

Unused EDA and waste streams should be neutralized before disposal.[22] Contact a licensed professional waste disposal service.

All solutions and stock materials must be collected as hazardous waste.[20] Quench reactive solutions by adding acetic acid dropwise until the yellow color disappears and gas evolution stops.[19]

Decision Framework for Reagent Selection

Choosing the right reagent requires balancing performance with practical and safety considerations. The following diagram illustrates a logical workflow for this decision-making process.

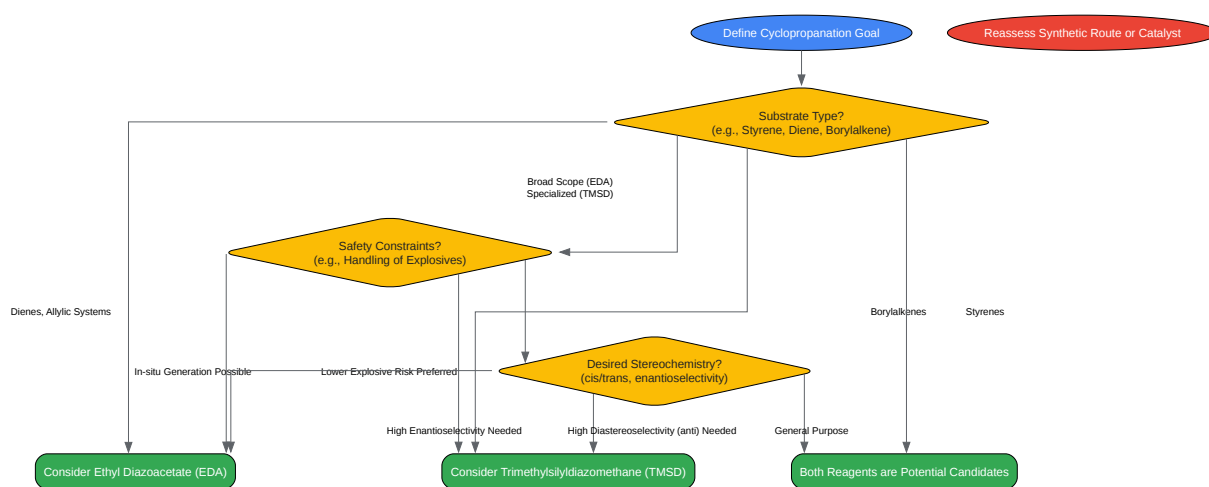

[Click to download full resolution via product page](#)

Caption: Decision tree for selecting a cyclopropanation reagent.

Conclusion

Both **ethyl diazoacetate** and trimethylsilyldiazomethane are powerful reagents for the synthesis of cyclopropanes.

- **Ethyl Diazoacetate** (EDA) is a versatile and widely studied reagent with a broad substrate scope. It is particularly well-suited for asymmetric cyclopropanation when paired with chiral catalysts, offering access to enantioenriched products. However, its significant explosive hazard necessitates careful handling and often in situ preparation for larger-scale reactions. [\[17\]](#)[\[22\]](#)
- Trimethylsilyldiazomethane (TMSD) is often considered a safer alternative to diazomethane and EDA, although it is extremely toxic upon inhalation.[\[19\]](#)[\[21\]](#) It demonstrates excellent reactivity and can provide high levels of diastereoselectivity, making it a valuable tool for specific synthetic targets, such as silyl-substituted cyclopropanes.[\[9\]](#)[\[11\]](#)

Ultimately, the selection between EDA and TMSD will be guided by the specific requirements of the chemical transformation, including the nature of the alkene, the desired stereochemical outcome, and the safety infrastructure available to the researcher.

Need Custom Synthesis?

BenchChem offers custom synthesis for rare earth carbides and specific isotopic labeling.

Email: info@benchchem.com or [Request Quote Online](#).

References

- 1. Cyclopropanation - Wikipedia [en.wikipedia.org]
- 2. [researchgate.net](https://www.researchgate.net) [[researchgate.net](https://www.researchgate.net)]
- 3. Recent Synthetic Advances on the Use of Diazo Compounds Catalyzed by Metalloporphyrins - PMC [[pmc.ncbi.nlm.nih.gov](https://pubmed.ncbi.nlm.nih.gov/)]
- 4. Pd-Catalyzed Regioselective Cyclopropanation of 2-Substituted 1,3-Dienes - PMC [[pmc.ncbi.nlm.nih.gov](https://pubmed.ncbi.nlm.nih.gov/)]
- 5. [researchgate.net](https://www.researchgate.net) [[researchgate.net](https://www.researchgate.net)]
- 6. Catalytic cyclopropanation of electron deficient alkenes mediated by chiral and achiral sulfides: scope and limitations in reactions involving phenyldiazomethane and ethyl diazoacetate - Journal of the Chemical Society, Perkin Transactions 1 (RSC Publishing) [pubs.rsc.org]

- 7. Challenging cyclopropanation reactions on non-activated double bonds of fatty esters - RSC Advances (RSC Publishing) DOI:10.1039/C7RA01017F [pubs.rsc.org]
- 8. Cyclopropanation of alkenes with ethyl diazoacetate catalysed by ruthenium porphyrin complexes - Chemical Communications (RSC Publishing) [pubs.rsc.org]
- 9. Stereoselective Cyclopropanation of 1,1-Diborylalkenes via Palladium-Catalyzed (Trimethylsilyl)diazomethane Insertion - PMC [pmc.ncbi.nlm.nih.gov]
- 10. pubs.acs.org [pubs.acs.org]
- 11. DSpace [dr.lib.iastate.edu]
- 12. research-hub.nrel.gov [research-hub.nrel.gov]
- 13. researchgate.net [researchgate.net]
- 14. Stereoselective Cyclopropanation of 1,1-Diborylalkenes via Palladium-Catalyzed (Trimethylsilyl)diazomethane Insertion - PubMed [pubmed.ncbi.nlm.nih.gov]
- 15. Experimental and Computational Studies for the Synthesis of Functionalized Cyclopropanes from 2-Substituted Allylic Derivatives with Ethyl Diazoacetate - PubMed [pubmed.ncbi.nlm.nih.gov]
- 16. Metalloradical Activation of In Situ-Generated α -Alkynyldiazomethanes for Asymmetric Radical Cyclopropanation of Alkenes - PMC [pmc.ncbi.nlm.nih.gov]
- 17. Organic Syntheses Procedure [orgsyn.org]
- 18. capotchem.com [capotchem.com]
- 19. ehs.ucsb.edu [ehs.ucsb.edu]
- 20. ehs.yale.edu [ehs.yale.edu]
- 21. ehs.unm.edu [ehs.unm.edu]
- 22. researchgate.net [researchgate.net]
- 23. chemicalbook.com [chemicalbook.com]
- To cite this document: BenchChem. [A Comparative Guide to Ethyl Diazoacetate and Trimethylsilyldiazomethane for Cyclopropanation]. BenchChem, [2025]. [Online PDF]. Available at: [https://www.benchchem.com/product/b1670405#ethyl-diazoacetate-vs-trimethylsilyldiazomethane-for-cyclopropanation]

Disclaimer & Data Validity:

The information provided in this document is for Research Use Only (RUO) and is strictly not intended for diagnostic or therapeutic procedures. While BenchChem strives to provide accurate protocols, we make no warranties, express or implied, regarding the fitness of this product for every specific experimental setup.

Technical Support: The protocols provided are for reference purposes. Unsure if this reagent suits your experiment? [[Contact our Ph.D. Support Team for a compatibility check](#)]

Need Industrial/Bulk Grade? [Request Custom Synthesis Quote](#)

BenchChem

Our mission is to be the trusted global source of essential and advanced chemicals, empowering scientists and researchers to drive progress in science and industry.

Contact

Address: 3281 E Guasti Rd
Ontario, CA 91761, United States
Phone: (601) 213-4426
Email: info@benchchem.com