

# Technical Support Center: 6-Chlorothymine Solution Stability

**Author:** BenchChem Technical Support Team. **Date:** May 2026

## Compound of Interest

Compound Name: 6-Chlorothymine

CAS No.: 1627-28-7

Cat. No.: B167606

[Get Quote](#)

Welcome to the technical support center for **6-Chlorothymine**. This resource is designed for researchers, scientists, and drug development professionals to provide in-depth guidance on maintaining the stability of **6-Chlorothymine** in solution. Here, you will find troubleshooting guides and frequently asked questions (FAQs) to address common challenges encountered during experimental work. Our goal is to equip you with the scientific understanding and practical protocols necessary to ensure the integrity of your experiments.

## I. Understanding the Instability of 6-Chlorothymine

**6-Chlorothymine**, a halogenated derivative of the nucleobase thymine, is a valuable building block in medicinal chemistry and drug discovery.<sup>[1]</sup> However, its reactivity, which makes it a useful synthetic intermediate, also contributes to its instability in solution. The primary degradation pathway for **6-Chlorothymine** in aqueous solution is hydrolysis, a reaction where water acts as a nucleophile, leading to the displacement of the chlorine atom. This process is significantly influenced by pH, temperature, and the presence of other nucleophiles in the solution.

The C6 position of the pyrimidine ring is susceptible to nucleophilic attack. The presence of the electron-withdrawing chlorine atom further enhances the electrophilicity of this position, making it a prime target for nucleophiles.

## II. Troubleshooting Guide: Common Issues with 6-Chlorothymine Solutions

This section addresses specific problems you may encounter when working with **6-Chlorothymine** solutions and provides actionable solutions based on chemical principles.

### Problem 1: Rapid Degradation of 6-Chlorothymine in Aqueous Solution

Symptoms:

- Loss of starting material observed by HPLC or TLC analysis over a short period.
- Appearance of unexpected peaks in your chromatogram.
- Inconsistent experimental results.

Root Cause Analysis:

The primary cause of rapid degradation is hydrolysis, which is highly pH-dependent. The predicted pKa of **6-Chlorothymine** is approximately 6.52.<sup>[2]</sup> At or near this pH, and especially under basic conditions (pH > 7), the rate of hydrolysis increases significantly. This is because the concentration of the more nucleophilic hydroxide ion (OH<sup>-</sup>) is higher at elevated pH.

Solutions:

- **pH Control:** Maintain the pH of your aqueous solution in the acidic range, ideally between pH 3 and 5, to minimize the rate of hydrolysis.<sup>[3][4][5]</sup>
- **Buffer Selection:** Be mindful of your buffer choice. Some common biological buffers, especially those with nucleophilic functional groups (e.g., Tris, which contains a primary amine), can directly react with **6-Chlorothymine**, accelerating its degradation.<sup>[6][7]</sup> Consider using non-nucleophilic buffers such as MES or citrate.

- Temperature Management: Perform your experiments at the lowest temperature compatible with your protocol. Degradation reactions, including hydrolysis, are accelerated at higher temperatures.[3][4]

## Problem 2: Precipitation of 6-Chlorothymine in Solution

Symptoms:

- Cloudiness or visible particulate matter in your solution.
- Difficulty in achieving the desired concentration.

Root Cause Analysis:

**6-Chlorothymine** has limited solubility in many common solvents. Precipitation can occur due to:

- Supersaturation: Dissolving the compound in a minimal amount of hot solvent can lead to rapid crystallization upon cooling.[8][9]
- Solvent Choice: Using a solvent in which **6-Chlorothymine** has low solubility.
- pH Shift: Changes in pH can affect the ionization state of the molecule and thus its solubility.

Solutions:

- Solvent System Optimization: For stock solutions, consider using a co-solvent system. A common practice is to dissolve the compound in a minimal amount of a polar aprotic solvent like DMSO or DMF and then dilute it with the aqueous buffer.
- Controlled Cooling: If you are preparing a saturated solution by heating, allow it to cool slowly to prevent rapid precipitation and encourage the formation of purer crystals if recrystallization is the goal.[8]
- pH Adjustment: Ensure the pH of your final solution is one where **6-Chlorothymine** is sufficiently soluble.

## III. Frequently Asked Questions (FAQs)

Q1: What is the primary degradation pathway for **6-Chlorothymine** in solution?

A1: The primary degradation pathway is hydrolysis, where the chlorine atom at the C6 position is substituted by a hydroxyl group from water or hydroxide ions. This reaction is a nucleophilic substitution. Under acidic conditions, the reaction is generally slower. Under neutral to basic conditions, the rate of hydrolysis increases significantly.

Q2: What are the expected degradation products of **6-Chlorothymine**?

A2: The primary degradation product is 6-hydroxythymine (also known as 5-methylbarbituric acid). Further degradation of the pyrimidine ring can occur under harsh conditions, but 6-hydroxythymine is the initial and most common degradation product. Identification of degradation products can be achieved using techniques like LC-MS/MS.[\[10\]](#)[\[11\]](#)

Q3: How should I prepare a stable stock solution of **6-Chlorothymine**?

A3: For maximum stability, prepare a concentrated stock solution in an anhydrous polar aprotic solvent such as DMSO or DMF. Store this stock solution at -20°C or -80°C in small aliquots to avoid repeated freeze-thaw cycles. When preparing aqueous working solutions, dilute the stock solution into a pre-chilled, acidic buffer (pH 3-5) immediately before use.

Q4: Can I use phosphate buffer with **6-Chlorothymine**?

A4: While phosphate itself is not highly nucleophilic, phosphate buffers are typically used in the pH range of 6.2 to 8.2, which is where **6-Chlorothymine** is more prone to hydrolysis. If you must use a phosphate buffer, opt for a pH closer to 6.2 and keep the solution cold. However, a non-nucleophilic buffer in the acidic pH range is a safer choice for long-term stability.

Q5: How does light affect the stability of **6-Chlorothymine** solutions?

A5: Halogenated organic compounds can be susceptible to photodegradation.[\[12\]](#)[\[13\]](#) It is good practice to protect **6-Chlorothymine** solutions from light, especially during long-term storage or prolonged experiments, by using amber vials or covering the container with aluminum foil. Forced degradation studies under UV/Vis light can help determine the photosensitivity of your specific formulation.[\[14\]](#)[\[15\]](#)

## IV. Experimental Protocols

## Protocol 1: Preparation of a Stable 6-Chlorothymine Stock Solution

- Materials: **6-Chlorothymine** (solid), anhydrous DMSO, sterile microcentrifuge tubes.
- Procedure: a. Weigh the desired amount of **6-Chlorothymine** in a sterile microcentrifuge tube. b. Add the appropriate volume of anhydrous DMSO to achieve the desired stock concentration (e.g., 100 mM). c. Vortex the tube until the solid is completely dissolved. d. Aliquot the stock solution into smaller, single-use volumes in sterile microcentrifuge tubes. e. Store the aliquots at -20°C or -80°C, protected from light.

## Protocol 2: Monitoring the Stability of 6-Chlorothymine in an Aqueous Buffer

- Materials: **6-Chlorothymine** stock solution (in DMSO), aqueous buffer of choice (e.g., 50 mM citrate buffer, pH 4.0), HPLC system with a C18 column, HPLC grade solvents.
- Procedure: a. Prepare a working solution of **6-Chlorothymine** in the chosen aqueous buffer at the desired final concentration (e.g., 1 mM). b. Immediately after preparation (t=0), inject an aliquot onto the HPLC system to obtain an initial chromatogram and determine the peak area of **6-Chlorothymine**. c. Store the working solution under the desired experimental conditions (e.g., room temperature, protected from light). d. At regular time intervals (e.g., 1, 2, 4, 8, 24 hours), inject an aliquot of the working solution onto the HPLC system. e. Monitor the decrease in the peak area of **6-Chlorothymine** and the appearance of any new peaks corresponding to degradation products. f. Calculate the percentage of **6-Chlorothymine** remaining at each time point relative to the initial time point.

## V. Visualizations

### Diagram 1: Factors Influencing 6-Chlorothymine Stability

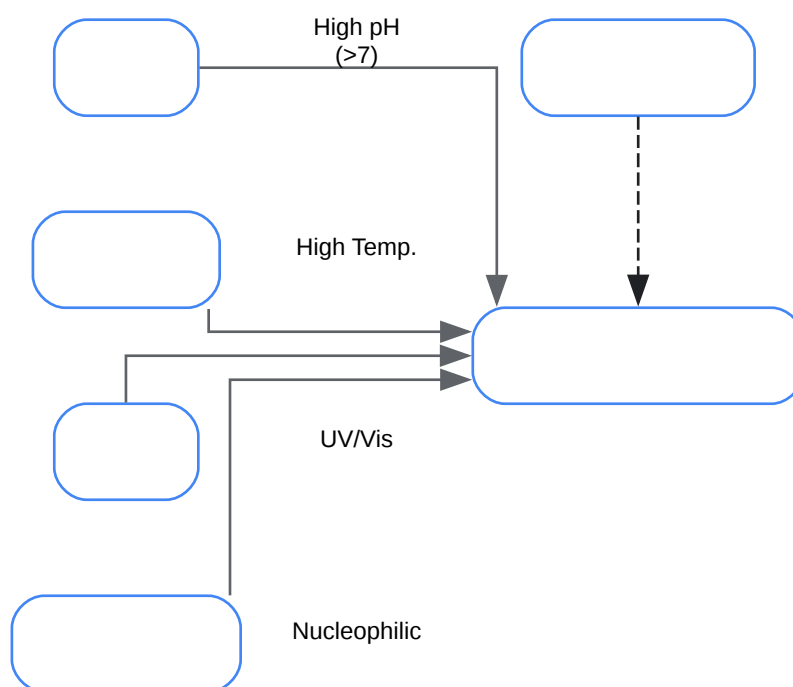

[Click to download full resolution via product page](#)

Caption: Key environmental factors affecting the stability of **6-Chlorothymine** in solution.

## Diagram 2: Proposed Degradation Pathway of 6-Chlorothymine

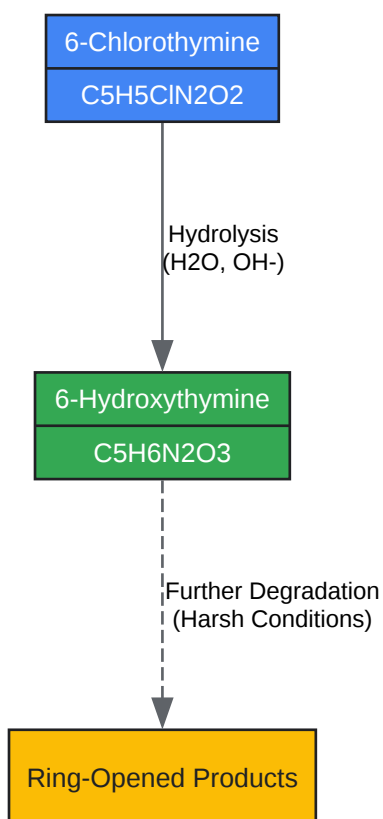

[Click to download full resolution via product page](#)

Caption: Proposed primary degradation pathway of **6-Chlorothymine** via hydrolysis.

## VI. Data Summary

Parameter	Condition	Effect on Stability	Recommendation
pH	Acidic (3-5)	Increased stability	Use acidic buffers.
Neutral to Basic (>6)	Decreased stability	Avoid neutral or basic conditions for prolonged periods.	
Temperature	Low (2-8°C)	Increased stability	Store solutions cold and perform experiments at low temperatures.
High (>25°C)	Decreased stability	Avoid heating solutions unless necessary for solubilization.	
Solvent/Buffer	Aprotic (DMSO, DMF)	High stability (anhydrous)	Use for preparing concentrated stock solutions.
Aqueous (non-nucleophilic)	Moderate stability (pH-dependent)	Use for working solutions, preferably at acidic pH.	
Aqueous (nucleophilic, e.g., Tris)	Low stability	Avoid if possible, or use for very short-term experiments.	
Light	Protected (Amber vial)	Increased stability	Protect solutions from light during storage and use.
Exposed to UV/Vis	Potential for degradation	Conduct photostability studies if light exposure is unavoidable.	

## VII. References

- Gumieniczek, A., Berecka-Rycerz, A., Hubicka, U., Żmudzki, P., Lejwoda, K., & Kozyra, P. (2020). Photodegradation of the H1 Antihistaminic Topical Drugs Emedastine, Epinastine, and Ketotifen and ROS Tests for Estimations of Their Potent Phototoxicity. *Pharmaceutics*, 12(6), 560. [\[Link\]](#)
- Thombre, A. G., & Koli, P. N. (2000). Influence of pH, Temperature and Buffers on Cefepime Degradation Kinetics and Stability Predictions in Aqueous Solutions. *Journal of Pharmaceutical and Biomedical Analysis*, 23(1), 15-26. [\[Link\]](#)
- Pharmaguideline. (n.d.). Forced Degradation Study in Pharmaceutical Stability. [\[Link\]](#)
- Ghebre-Sellassie, I., & Chow, K. (1982). Kinetics of Hydrolysis of Methenamine. *Journal of Pharmaceutical Sciences*, 71(11), 1269-1272. [\[Link\]](#)
- Falk, B., & Garrett, E. R. (1987). Degradation kinetics and mechanisms of a new cephalosporin, cefixime, in aqueous solution. *Journal of Pharmaceutical Sciences*, 76(S11), S68-S68. [\[Link\]](#)
- Miyashita, T., Yasuda, K., & Uda, T. (2022). Kinetics and mechanism of hydrolysis of PF6<sup>-</sup> accelerated by H<sup>+</sup> or Al<sup>3+</sup> in aqueous solution. *Environmental Science: Water Research & Technology*, 8(1), 116-125. [\[Link\]](#)
- Scientific Research Publishing. (2022). Drug-excipient Interactions: Case Studies and Overview of Drug Degradation Pathways. *Pharmacology & Pharmacy*, 13(12), 497-526. [\[Link\]](#)
- Mironov, I. V. (2007). Stability of diammine and chloroammine gold(I) complexes in aqueous solution. *Russian Journal of Inorganic Chemistry*, 52(6), 960-962. [\[Link\]](#)
- European Medicines Agency. (1996). Q1B Photostability Testing of New Active Substances and Medicinal Products. [\[Link\]](#)
- Bajaj, S., Singla, D., & Sakhuja, N. (2012). Development of forced degradation and stability indicating studies of drugs—A review. *Journal of Applied Pharmaceutical Science*, 2(3), 129-138. [\[Link\]](#)
- LibreTexts Chemistry. (2022). 3.6F: Troubleshooting. [\[Link\]](#)

- Wang, M., & Schibye, A. (2005). Analysis of chlorothalonil and degradation products in soil and water by GC/MS and LC/MS. *Journal of Agricultural and Food Chemistry*, 53(1), 11-19. [\[Link\]](#)
- Baertschi, S. W., Alsante, K. M., & Reed, R. A. (2011). Photostability studies of drug substances and products: Practical implications of the ICH guideline. *Pharmaceutical Technology*, 35(4), 50-57. [\[Link\]](#)
- Drug Hunter. (2025). Case Studies. [\[Link\]](#)
- Laskar, P. A., & Ayres, J. W. (1977). Degradation of carmustine in mixed solvent and nonaqueous media. *Journal of Pharmaceutical Sciences*, 66(8), 1073-1076. [\[Link\]](#)
- Gupta, K. R., Pounikar, A. R., & Umekar, M. J. (2019). Drug Excipient Compatibility Testing Protocols and Characterization: A Review. *Asian Journal of Chemistry*, 31(1), 1-8. [\[Link\]](#)
- Newman, J. (2015). Universal buffers for use in biochemistry and biophysical experiments. *Protein Science*, 24(7), 1177-1180. [\[Link\]](#)
- Miyashita, T., Yasuda, K., & Uda, T. (2022). Kinetics and mechanism of hydrolysis of PF6 – accelerated by H<sup>+</sup> or Al<sup>3+</sup> in aqueous solution. *Environmental Science: Water Research & Technology*, 8(1), 116-125. [\[Link\]](#)
- Neilson, A. R., & Reineccius, G. A. (2021). Effect of pH and concentration on the chemical stability and reaction kinetics of thiamine mononitrate and thiamine chloride hydrochloride in solution. *Food Chemistry*, 354, 129533. [\[Link\]](#)
- ResearchGate. (n.d.). Case Studies of CNS Drug Optimization-Medicinal Chemistry and CNS Biology Perspectives. [\[Link\]](#)
- Caron. (n.d.). RAPID & REPEATABLE PHOTOSTABILITY RESULTS IN AN ICH Q1B OPTION II CHAMBER. [\[Link\]](#)
- Klimenko, N. A., & Belyaeva, E. A. (2020). Stability of Rhodamine Lactone Cycle in Solutions: Chain–Ring Tautomerism, Acid–Base Equilibria, Interaction with Lewis Acids, and Fluorescence. *Molecules*, 25(18), 4153. [\[Link\]](#)

- Fisher Digital Publications. (n.d.). Drug-Excipient Compatibility Studies in Formulation Development: Current Trends and Techniques. [\[Link\]](#)
- Singh, S., et al. (2013). LC and LC–MS/MS studies for the identification and characterization of degradation products of acebutolol. *Journal of Pharmaceutical and Biomedical Analysis*, 85, 1-11. [\[Link\]](#)
- Biomedical Journal of Scientific & Technical Research. (2022). Forced Degradation – A Review. [\[Link\]](#)
- Linner, E., & Schonenberger, H. (1987). Study on the stability of the oxime HI 6 in aqueous solution. *Archiv der Pharmazie*, 320(6), 567-573. [\[Link\]](#)
- Castro, E. A., et al. (1986). Kinetics of hydrolysis and aminolysis of methyl chloroformate in aqueous solution. *Journal of the Chemical Society, Perkin Transactions 2*, (12), 1939-1942. [\[Link\]](#)
- International Association for Generic Drugs and Medical Devices. (n.d.). Photostability. [\[Link\]](#)
- Kamberi, M., & Tsutsumi, K. (2004). Forced Degradation Studies: Regulatory Considerations and Implementation. *BioProcess International*, 2(10), 48-54. [\[Link\]](#)
- National Center for Biotechnology Information. (2023). Drug-Excipient Compatibility Study Through a Novel Vial-in-Vial Experimental Setup. *AAPS PharmSciTech*, 24(4), 114. [\[Link\]](#)
- Chromatography Online. (2024). LC–QTOF-MS Identifies Degradation Products and Process-Related Substances of Brivaracetam. [\[Link\]](#)
- Drug Hunter. (n.d.). Category - Case Studies. [\[Link\]](#)
- Dinte, E., Bodoki, E., Leucuta, S., & Iuga, C. A. (2013). Compatibility studies between drugs and excipients in the preformulation phase of buccal mucoadhesive systems. *Farmacia*, 61(4), 703-712. [\[Link\]](#)
- Marin, A., & Barbas, C. (2004). LC/MS for the degradation profiling of cough-cold products under forced conditions. *Journal of Pharmaceutical and Biomedical Analysis*, 35(5), 1047-1055. [\[Link\]](#)

### Need Custom Synthesis?

BenchChem offers custom synthesis for rare earth carbides and specific isotopic labeling.

Email: [info@benchchem.com](mailto:info@benchchem.com) or [Request Quote Online](#).

## Sources

- 1. Drug-excipient compatibility testing using a high-throughput approach and statistical design - PubMed [[pubmed.ncbi.nlm.nih.gov](https://pubmed.ncbi.nlm.nih.gov)]
- 2. [researchgate.net](https://researchgate.net) [[researchgate.net](https://researchgate.net)]
- 3. Influence of pH, temperature and buffers on cefepime degradation kinetics and stability predictions in aqueous solutions - PubMed [[pubmed.ncbi.nlm.nih.gov](https://pubmed.ncbi.nlm.nih.gov)]
- 4. Kinetics of hydrolysis of methenamine - PubMed [[pubmed.ncbi.nlm.nih.gov](https://pubmed.ncbi.nlm.nih.gov)]
- 5. Effect of pH and concentration on the chemical stability and reaction kinetics of thiamine mononitrate and thiamine chloride hydrochloride in solution - PMC [[pmc.ncbi.nlm.nih.gov](https://pmc.ncbi.nlm.nih.gov)]
- 6. Buffers for Biochemical Reactions [[promega.com](https://promega.com)]
- 7. Universal buffers for use in biochemistry and biophysical experiments - PMC [[pmc.ncbi.nlm.nih.gov](https://pmc.ncbi.nlm.nih.gov)]
- 8. [researchgate.net](https://researchgate.net) [[researchgate.net](https://researchgate.net)]
- 9. [caronscientific.com](https://caronscientific.com) [[caronscientific.com](https://caronscientific.com)]
- 10. Identification and analysis of the degradation products of chlorothalonil in vegetables - PubMed [[pubmed.ncbi.nlm.nih.gov](https://pubmed.ncbi.nlm.nih.gov)]
- 11. LC and LC–MS/MS studies for the identification and characterization of degradation products of acebutolol - PMC [[pmc.ncbi.nlm.nih.gov](https://pmc.ncbi.nlm.nih.gov)]
- 12. Photodegradation of the H1 Antihistaminic Topical Drugs Emedastine, Epinastine, and Ketotifen and ROS Tests for Estimations of Their Potent Phototoxicity - PubMed [[pubmed.ncbi.nlm.nih.gov](https://pubmed.ncbi.nlm.nih.gov)]
- 13. [ema.europa.eu](https://ema.europa.eu) [[ema.europa.eu](https://ema.europa.eu)]
- 14. Forced Degradation Study in Pharmaceutical Stability | Pharmaguideline [[pharmaguideline.com](https://pharmaguideline.com)]
- 15. [researchgate.net](https://researchgate.net) [[researchgate.net](https://researchgate.net)]

- To cite this document: BenchChem. [Technical Support Center: 6-Chlorothymine Solution Stability]. BenchChem, [2026]. [Online PDF]. Available at: [<https://www.benchchem.com/product/b167606/docs#technical-support-center-6-chlorothymine-solution-stability>]

---

### Disclaimer & Data Validity:

The information provided in this document is for Research Use Only (RUO) and is strictly not intended for diagnostic or therapeutic procedures. While BenchChem strives to provide accurate protocols, we make no warranties, express or implied, regarding the fitness of this product for every specific experimental setup.

**Technical Support:** The protocols provided are for reference purposes. Unsure if this reagent suits your experiment?

**Need Industrial/Bulk Grade?** [Request Custom Synthesis Quote](#)

## BenchChem

Our mission is to be the trusted global source of essential and advanced chemicals, empowering scientists and researchers to drive progress in science and industry.

### Contact

Address: 3281 E Guasti Rd  
Ontario, CA 91761, United States  
Phone: (601) 213-4426  
Email: [info@benchchem.com](mailto:info@benchchem.com)

[Contact our Ph.D. Support Team for a compatibility check](#)