

Spectroscopic Characterization of 2,5-Difluoro-terephthalonitrile: A Predictive and Methodological Guide

Author: BenchChem Technical Support Team. **Date:** May 2026

Compound of Interest

Compound Name:	1,4-Benzenedicarbonitrile, 2,5-difluoro-
CAS No.:	1897-49-0
Cat. No.:	B167984

[Get Quote](#)

Abstract

This technical guide provides a comprehensive overview of the anticipated spectroscopic properties of 2,5-difluoro-terephthalonitrile. In the absence of extensive publicly available experimental data for this specific molecule, this document leverages established principles of nuclear magnetic resonance (NMR), infrared (IR), and mass spectrometry (MS), along with comparative data from structurally analogous compounds, to predict its spectral characteristics. Detailed, field-proven protocols for acquiring high-fidelity spectroscopic data are also presented to guide researchers in the empirical analysis of this and similar fluorinated aromatic compounds. This guide is intended for researchers, scientists, and professionals in drug development and materials science who are engaged in the synthesis and characterization of novel fluorinated aromatics.

Introduction and Molecular Structure

2,5-Difluoro-terephthalonitrile is a halogenated aromatic compound featuring a benzene ring substituted with two fluorine atoms and two nitrile groups in a para-dicyano arrangement. The strategic placement of fluorine atoms can significantly influence a molecule's electronic properties, lipophilicity, and metabolic stability, making it a potentially valuable building block in medicinal chemistry and materials science. A thorough spectroscopic characterization is paramount for the unambiguous identification and purity assessment of this compound.

Below is the chemical structure of 2,5-difluoro-terephthalonitrile:

Figure 1: Chemical structure of 2,5-difluoro-terephthalonitrile.

Nuclear Magnetic Resonance (NMR) Spectroscopy

NMR spectroscopy is the most powerful tool for elucidating the structure of organic molecules in solution. For 2,5-difluoro-terephthalonitrile, ^1H , ^{13}C , and ^{19}F NMR will provide critical information.

Predicted ^1H NMR Spectrum

Due to the symmetry of the molecule, the two protons are chemically equivalent. Therefore, a single resonance is expected in the ^1H NMR spectrum.

- **Chemical Shift (δ):** The protons are attached to a benzene ring, and their chemical shift will be influenced by the electron-withdrawing effects of the adjacent fluorine and nitrile groups. The chemical shift is predicted to be in the downfield region, likely between 7.5 and 8.0 ppm.
- **Multiplicity:** The proton will be coupled to the adjacent fluorine atom and the meta fluorine atom. This will result in a complex multiplet, likely a doublet of doublets or a triplet of doublets, depending on the magnitude of the coupling constants.

Predicted ^{13}C NMR Spectrum

The ^{13}C NMR spectrum will show distinct signals for each unique carbon atom. Due to symmetry, there will be four signals for the aromatic carbons and one for the nitrile carbons.

Carbon Atom	Predicted Chemical Shift (δ , ppm)	Predicted Multiplicity (due to C-F coupling)
C-CN	110 - 115	Triplet (coupling to two F)
C-F	160 - 165	Doublet (large $^1J_{CF}$)
C-H	115 - 120	Doublet of doublets ($^2J_{CF}$ and $^3J_{CF}$)
C (quaternary)	130 - 135	Triplet (coupling to two F)
CN	115 - 120	Singlet

- Causality behind Predictions: The chemical shifts are estimated based on the known effects of nitrile and fluorine substituents on benzene rings.[1] The multiplicities arise from through-bond scalar coupling (J-coupling) between the ^{13}C and ^{19}F nuclei. The magnitude of the coupling constant is dependent on the number of bonds separating the coupled nuclei.

Predicted ^{19}F NMR Spectrum

The two fluorine atoms are chemically equivalent, so a single resonance is expected in the ^{19}F NMR spectrum.

- Chemical Shift (δ): The chemical shift of fluorine is sensitive to its electronic environment. For fluorinated benzenes, the chemical shift is typically in the range of -110 to -140 ppm relative to CFCl_3 .
- Multiplicity: The fluorine atom will be coupled to the adjacent proton and the meta proton, resulting in a multiplet, likely a doublet of doublets.

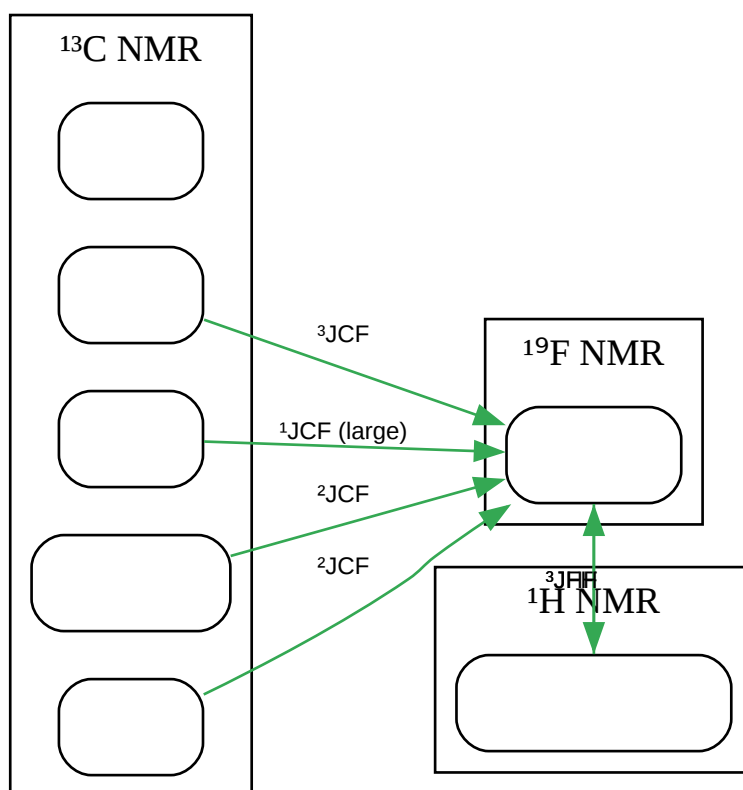

[Click to download full resolution via product page](#)

Figure 2: Predicted key NMR coupling relationships for 2,5-difluoro-terephthalonitrile.

Experimental Protocol for NMR Data Acquisition

- Sample Preparation:
 - Accurately weigh approximately 5-10 mg of the purified 2,5-difluoro-terephthalonitrile.
 - Dissolve the sample in ~0.6 mL of a deuterated solvent (e.g., CDCl_3 , DMSO-d_6) in a clean, dry NMR tube. Ensure the solvent is free of residual water.
 - Add a small amount of an internal standard (e.g., tetramethylsilane, TMS) if quantitative analysis or precise chemical shift referencing is required.
- Instrument Setup:

- Use a high-field NMR spectrometer (e.g., 400 MHz or higher) for better signal dispersion and resolution.
- Tune and match the probe for ^1H , ^{13}C , and ^{19}F frequencies.
- Shim the magnetic field to achieve optimal homogeneity.
- Data Acquisition:
 - ^1H NMR: Acquire a standard one-pulse ^1H spectrum. Typical parameters include a 30-degree pulse angle, a relaxation delay of 1-2 seconds, and 16-32 scans.
 - ^{13}C NMR: Acquire a proton-decoupled ^{13}C spectrum. Due to the lower natural abundance of ^{13}C , a larger number of scans (e.g., 1024 or more) and a longer relaxation delay (e.g., 2-5 seconds) are typically required.
 - ^{19}F NMR: Acquire a proton-decoupled ^{19}F spectrum. A one-pulse experiment with a 30-degree pulse and 16-32 scans is usually sufficient.
- Data Processing:
 - Apply Fourier transformation to the acquired free induction decays (FIDs).
 - Phase correct the spectra.
 - Reference the chemical shifts to the internal standard or the residual solvent peak.
 - Integrate the signals in the ^1H spectrum.

Infrared (IR) Spectroscopy

IR spectroscopy provides information about the functional groups present in a molecule by measuring the absorption of infrared radiation at specific wavenumbers corresponding to molecular vibrations.

Predicted IR Absorption Bands

Vibrational Mode	Predicted Wavenumber (cm ⁻¹)	Intensity
C-H stretch (aromatic)	3100 - 3000	Medium
C≡N stretch (nitrile)	2240 - 2220	Strong, sharp
C=C stretch (aromatic)	1600 - 1450	Medium to strong
C-F stretch	1250 - 1000	Strong
C-H bend (out-of-plane)	900 - 675	Strong

- Justification: The predicted wavenumbers are based on characteristic absorption ranges for these functional groups in aromatic compounds. The strong C≡N stretch is a particularly diagnostic feature for nitriles. The C-F stretch is also expected to be a prominent feature in the fingerprint region.

Experimental Protocol for ATR-FTIR Spectroscopy

- Sample Preparation:
 - Ensure the diamond crystal of the Attenuated Total Reflectance (ATR) accessory is clean by wiping it with a solvent such as isopropanol and allowing it to dry completely.
 - Place a small amount of the solid 2,5-difluoro-terephthalonitrile sample onto the center of the ATR crystal.
- Data Acquisition:
 - Lower the ATR pressure arm to ensure good contact between the sample and the crystal.
 - Collect a background spectrum of the empty ATR crystal.
 - Collect the sample spectrum. Typically, 16-32 scans are co-added to improve the signal-to-noise ratio.
 - The typical spectral range is 4000-400 cm⁻¹.

- Data Processing:
 - The software will automatically ratio the sample spectrum to the background spectrum to generate the absorbance or transmittance spectrum.
 - Perform baseline correction if necessary.
 - Label the significant peaks.

Mass Spectrometry (MS)

Mass spectrometry is a powerful analytical technique for determining the molecular weight and elemental composition of a compound, and for obtaining structural information through fragmentation analysis.

Predicted Mass Spectrum

- Molecular Ion ($M^{+\bullet}$): The molecular weight of 2,5-difluoro-terephthalonitrile ($C_8H_2F_2N_2$) is 176.02 g/mol . A strong molecular ion peak is expected at $m/z = 176$ in the electron ionization (EI) mass spectrum.
- Isotopic Pattern: The presence of ^{13}C will result in a small M+1 peak with an intensity of approximately 8.8% relative to the molecular ion peak.
- Fragmentation Pattern: Fluorinated aromatic compounds can exhibit complex fragmentation patterns. Common fragmentation pathways may include:
 - Loss of HCN ($m/z = 149$)
 - Loss of a fluorine atom ($m/z = 157$)
 - Fragmentation of the aromatic ring.

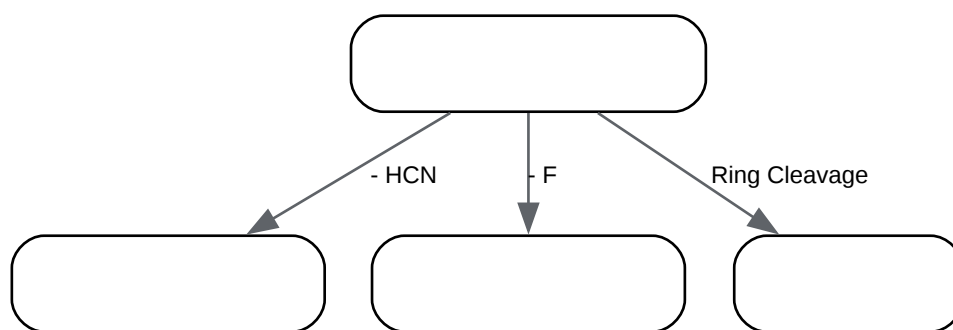

[Click to download full resolution via product page](#)

Figure 3: Plausible mass spectrometry fragmentation pathways for 2,5-difluoroterephthalonitrile.

Experimental Protocol for GC-MS Analysis

- Sample Preparation:
 - Prepare a dilute solution of the sample (e.g., 1 mg/mL) in a volatile solvent such as dichloromethane or ethyl acetate.
- Gas Chromatography (GC) Method:
 - Use a suitable capillary column (e.g., a non-polar DB-5 or a mid-polar DB-17).
 - Set an appropriate temperature program for the GC oven to ensure good separation of the analyte from any impurities. A typical program might start at 50°C, ramp to 250°C at 10°C/min, and hold for 5 minutes.
 - Set the injector temperature to 250°C and the transfer line temperature to 280°C.
- Mass Spectrometry (MS) Method:
 - Use electron ionization (EI) at a standard energy of 70 eV.
 - Scan a mass range that includes the expected molecular weight (e.g., m/z 40-300).
- Data Analysis:

- Identify the peak corresponding to 2,5-difluoro-terephthalonitrile in the total ion chromatogram (TIC).
- Examine the mass spectrum of this peak to identify the molecular ion and major fragment ions.
- Compare the obtained spectrum with a library of mass spectra if available.

Conclusion

While direct experimental spectroscopic data for 2,5-difluoro-terephthalonitrile is not readily available in the public domain, a comprehensive understanding of its expected spectral characteristics can be derived from the analysis of its structural features and comparison with analogous compounds. This guide provides a robust predictive framework for the ^1H , ^{13}C , and ^{19}F NMR, IR, and mass spectra of this molecule. The detailed experimental protocols included herein offer a standardized approach for researchers to obtain high-quality data for the empirical characterization of 2,5-difluoro-terephthalonitrile and other novel fluorinated aromatic compounds, ensuring scientific integrity and facilitating further research and development.

References

- PubChem. 2,5-Difluorobenzonitrile. National Center for Biotechnology Information. [[Link](#)]
- PubChem. Terephthalonitrile. National Center for Biotechnology Information. [[Link](#)]
- NIST. 1,3-Dicyanobenzene. In NIST Chemistry WebBook; Linstrom, P. J., Mallard, W. G., Eds.; National Institute of Standards and Technology: Gaithersburg, MD. [[Link](#)]
- Pavia, D. L.; Lampman, G. M.; Kriz, G. S.; Vyvyan, J. R. Introduction to Spectroscopy, 5th ed.; Cengage Learning: Boston, MA, 2015.
- Silverstein, R. M.; Webster, F. X.; Kiemle, D. J.; Bryce, D. L. Spectrometric Identification of Organic Compounds, 8th ed.; John Wiley & Sons: Hoboken, NJ, 2014.
- AZoM. (2017). Using Benchtop ^{19}F NMR to Evaluate Fluoroorganic Compounds. [[Link](#)]
- DergiPark. The Investigation of the Structural Properties of 3-nitrophthalonitrile Using Spectroscopic and Quantum Chemical Computational M. [[Link](#)]

Need Custom Synthesis?

BenchChem offers custom synthesis for rare earth carbides and specific isotopic labeling.

Email: info@benchchem.com or [Request Quote Online](#).

Sources

- 1. 2,3,5,6-Tetrafluoroterephthalonitrile | CAS#:1835-49-0 | Chemsrcc [chemsrc.com]
- To cite this document: BenchChem. [Spectroscopic Characterization of 2,5-Difluoroterephthalonitrile: A Predictive and Methodological Guide]. BenchChem, [2026]. [Online PDF]. Available at: [<https://www.benchchem.com/product/b167984/docs#spectroscopic-characterization-of-2-5-difluoro-terephthalonitrile-a-predictive-and-methodological-guide>]

Disclaimer & Data Validity:

The information provided in this document is for Research Use Only (RUO) and is strictly not intended for diagnostic or therapeutic procedures. While BenchChem strives to provide accurate protocols, we make no warranties, express or implied, regarding the fitness of this product for every specific experimental setup.

Technical Support: The protocols provided are for reference purposes. Unsure if this reagent suits your experiment?

Need Industrial/Bulk Grade? [Request Custom Synthesis Quote](#)

BenchChem

Our mission is to be the trusted global source of essential and advanced chemicals, empowering scientists and researchers to drive progress in science and industry.

Contact

Address: 3281 E Guasti Rd

Ontario, CA 91761, United States

Phone: (601) 213-4426

Email: info@benchchem.com

Contact our Ph.D. Support Team for a compatibility check