

Unraveling the Activity of p53-Reactivating Compounds: A Comparative Analysis

Author: BenchChem Technical Support Team. **Date:** April 2026

Compound of Interest

Compound Name: CP-312
Cat. No.: B1669481

[Get Quote](#)

A critical examination of the experimental data surrounding the small molecule CP-31398 and its alternatives in the quest to restore mutant p53 function in cancer therapeutics.

The small molecule CP-31398 has been the subject of numerous studies for its potential to reactivate the tumor suppressor protein p53, which is frequently mutated in human cancers. While a direct meta-analysis of "**CP-312**" is not readily available in published literature, a significant body of research exists for the closely related compound, CP-31398. This guide provides a comparative analysis of CP-31398 and other p53-reactivating small molecules, presenting key experimental data, detailed methodologies, and visual representations of the underlying biological pathways and experimental workflows. It is important to note that the nomenclature can be ambiguous, with other molecules such as the telomerase inhibitor MST-312 and the monoclonal antibody CSL312 (Garadacimab) also appearing in scientific literature under similar designations. This guide will focus on the p53-reactivating compounds, with CP-31398 as the central molecule of investigation.

Comparative Efficacy of p53-Reactivating Small Molecules

The reactivation of mutant p53 is a promising strategy in cancer therapy. Several small molecules, including CP-31398, PRIMA-1, RITA, and Nutlin-3, have been investigated for this purpose. Their efficacy varies across different cancer cell lines and is dependent on the specific p53 mutation. The following tables summarize key quantitative data from various studies.

Compound	Cell Line	p53 Status	Effect	Measurement	Result	Reference
CP-31398	A431 (human epidermoid carcinoma)	R273H mutant	Induction of p53 target genes	Gene Expression	Increased p21, mdm2, and Bax expression	[1]
CP-31398	Colon and prostate carcinoma cells	Mutant	Apoptosis Induction	Protein Levels	Altered Bcl2 and Bax levels	[1]
PRIMA-1	HNSCC cell lines	Mutant	p53 Reactivation	Apoptosis, Cell-cycle arrest	Induction of p21 and BAX, Caspase-3 cleavage	[2]
RITA	Fadu (HNSCC cell line)	Mutant	Apoptosis Induction	Protein Phosphorylation	Increased Ser-46-phosphorylated p53	[2]
Nutlin-3	HNSCC cell lines	Wild-type	Growth Suppression	-	Maximal effect in cells with MDM2-dependent p53 degradation	[2]
Nutlin-3	HUH-7 (Hepatocellular carcinoma)	Y220C mutant	No effect on cell cycle	Cell Cycle Analysis	No notable effect	[3]

PK7088	HUH-7				200 µM for	
	(Hepatocellular carcinoma)	Y220C mutant	G2/M cell-cycle arrest	Cell Cycle Analysis	6h caused G2/M arrest	[3]

HNSCC: Head and Neck Squamous Cell Carcinoma

Experimental Protocols

The evaluation of p53-reactivating compounds involves a series of well-defined experimental procedures to assess their impact on cancer cells. Below are the methodologies for key experiments cited in the literature.

Cell Viability and Growth Assays:

- Method: Tumor cell lines with varying TP53 status are treated with a range of concentrations of the p53-reactivating small molecules (e.g., PRIMA-1, CP-31398, RITA, and nutlin-3) individually or in combination with chemotherapeutic agents. Cell growth and viability are assessed at specific time points (e.g., 24, 48, 72 hours) using assays such as MTT (3-(4,5-dimethylthiazol-2-yl)-2,5-diphenyltetrazolium bromide) or trypan blue exclusion.

Cell Cycle Analysis:

- Method: Cells are treated with the compounds for a defined period. Subsequently, they are harvested, fixed (e.g., in ethanol), and stained with a fluorescent DNA-intercalating agent like propidium iodide. The DNA content of the cells is then analyzed by flow cytometry to determine the distribution of cells in different phases of the cell cycle (G1, S, G2/M).

Apoptosis Assays:

- Method: Apoptosis induction is quantified using various techniques. One common method is the TUNEL (Terminal deoxynucleotidyl transferase dUTP nick end labeling) assay, which detects DNA fragmentation, a hallmark of apoptosis. Another approach is to measure the cleavage of caspase-3, a key executioner caspase, and its substrate PARP (poly(ADP-ribose) polymerase) by Western blotting. The expression levels of pro-apoptotic (e.g., Bax) and anti-apoptotic (e.g., Bcl2) proteins are also frequently assessed.

p53 Reactivation and Target Gene Expression:

- Method: To confirm the reactivation of p53, nuclear accumulation of the protein is observed via immunofluorescence or subcellular fractionation followed by Western blotting. The functional restoration of p53 is determined by measuring the upregulation of its downstream target genes, such as p21 and BAX, at the mRNA level (using quantitative real-time PCR) and protein level (using Western blotting).

Visualizing the Mechanisms and Workflows

To better understand the complex interactions and experimental processes involved in the study of p53-reactivating compounds, the following diagrams have been generated using the Graphviz DOT language.

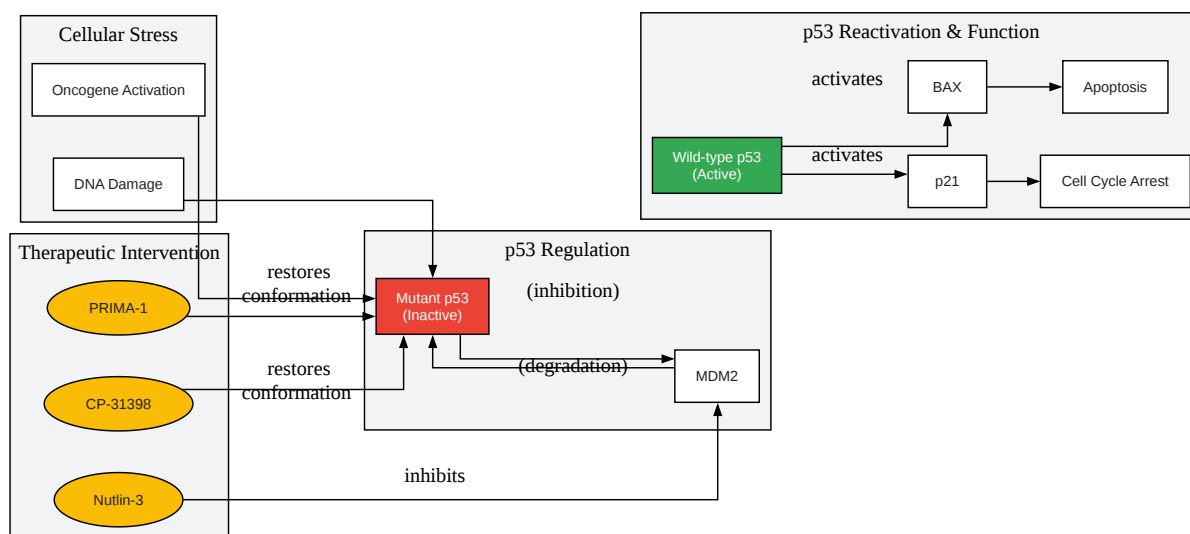

[Click to download full resolution via product page](#)

Caption: p53 signaling pathway and points of intervention by small molecules.

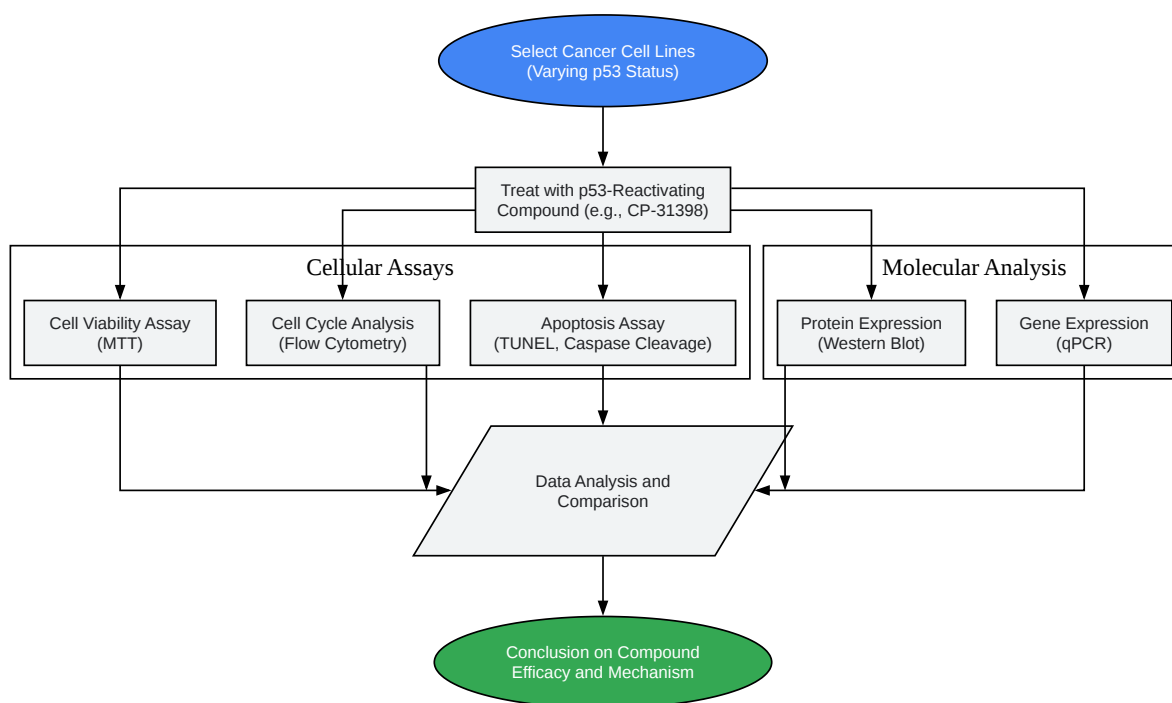

[Click to download full resolution via product page](#)

Caption: A typical experimental workflow for evaluating p53-reactivating compounds.

Conflicting Evidence and Future Directions

It is crucial to acknowledge that the mechanism of action of CP-31398 is not without controversy. Some studies have suggested that CP-31398 does not directly bind to the p53 core domain or stabilize the protein in vitro.[3] Instead, it has been proposed to act as a DNA intercalator, which could indirectly lead to p53 activation as part of a broader DNA damage response.[3] This highlights the importance of employing a multi-faceted experimental

approach to validate the on-target effects of putative p53-reactivating compounds. Future research should focus on direct biophysical binding assays and cellular thermal shift assays to unequivocally demonstrate target engagement. Furthermore, the use of isogenic cell lines differing only in their p53 mutation status is essential to confirm that the observed cellular effects are indeed p53-dependent.[3]

In conclusion, while CP-31398 and other small molecules have shown promise in preclinical models for reactivating mutant p53, a thorough and critical evaluation of the experimental evidence is paramount. The data presented in this guide, along with the outlined experimental protocols and pathway diagrams, provide a framework for researchers and drug development professionals to navigate this complex and evolving field.

Need Custom Synthesis?

BenchChem offers custom synthesis for rare earth carbides and specific isotopic labeling.

Email: info@benchchem.com or [Request Quote Online](#).

References

- 1. CP-31398 restores mutant p53 tumor suppressor function and inhibits UVB-induced skin carcinogenesis in mice - PMC [[pmc.ncbi.nlm.nih.gov](https://pubmed.ncbi.nlm.nih.gov/)]
- 2. p53-Reactivating small molecules induce apoptosis and enhance chemotherapeutic cytotoxicity in head and neck squamous cell carcinoma - PMC [[pmc.ncbi.nlm.nih.gov](https://pubmed.ncbi.nlm.nih.gov/)]
- 3. Small molecule induced reactivation of mutant p53 in cancer cells - PMC [[pmc.ncbi.nlm.nih.gov](https://pubmed.ncbi.nlm.nih.gov/)]
- To cite this document: BenchChem. [Unraveling the Activity of p53-Reactivating Compounds: A Comparative Analysis]. BenchChem, [2026]. [Online PDF]. Available at: [<https://www.benchchem.com/product/b1669481/docs#unraveling-the-activity-of-p53-reactivating-compounds-a-comparative-analysis>]

Disclaimer & Data Validity:

The information provided in this document is for Research Use Only (RUO) and is strictly not intended for diagnostic or therapeutic procedures. While BenchChem strives to provide

accurate protocols, we make no warranties, express or implied, regarding the fitness of this product for every specific experimental setup.

Technical Support: The protocols provided are for reference purposes. Unsure if this reagent suits your experiment?

Need Industrial/Bulk Grade? [Request Custom Synthesis Quote](#)

BenchChem

Our mission is to be the trusted global source of essential and advanced chemicals, empowering scientists and researchers to drive progress in science and industry.

Contact

Address: 3281 E Guasti Rd

Ontario, CA 91761, United States

Phone: (601) 213-4426

Email: info@benchchem.com

[Contact our Ph.D. Support Team for a compatibility check](#)