

# The Role of CP-31398 in Restoring p53 Function: A Technical Guide

**Author:** BenchChem Technical Support Team. **Date:** April 2026

## Compound of Interest

Compound Name: CP-31398 dihydrochloride

CAS No.: 1217195-61-3

Cat. No.: B1669482

[Get Quote](#)

For Researchers, Scientists, and Drug Development Professionals

## Abstract

The tumor suppressor protein p53 is a critical regulator of cellular stress responses, including cell cycle arrest, DNA repair, and apoptosis. Its inactivation, frequently through mutation, is a hallmark of over half of all human cancers, making the restoration of its function a highly sought-after therapeutic strategy. CP-31398, a styrylquinazoline derivative, has emerged as a significant small molecule in this field, demonstrating the ability to restore wild-type function to mutant p53 and stabilize the wild-type protein. This technical guide provides an in-depth analysis of the core mechanisms of CP-31398, detailing its impact on p53 conformation, stability, and downstream signaling pathways. It consolidates quantitative data from key studies, outlines detailed experimental protocols for assessing its activity, and presents visual representations of the molecular pathways involved.

## Introduction

The p53 protein acts as a central hub in the cellular response to genotoxic stress. Upon activation, it functions as a transcription factor, inducing the expression of genes that

orchestrate a variety of anti-proliferative and pro-apoptotic cellular processes. Mutations in the TP53 gene can lead to the expression of a dysfunctional protein that is unable to bind to its target DNA sequences, thereby abrogating its tumor-suppressive capabilities.

CP-31398 was identified through a screening process aimed at discovering compounds capable of restoring the wild-type conformation of mutant p53.[1] Subsequent research has revealed its dual ability to not only rescue the function of certain p53 mutants but also to stabilize and enhance the activity of wild-type p53.[2] This guide delves into the molecular underpinnings of CP-31398's action, providing a comprehensive resource for researchers in oncology and drug development.

## Mechanism of Action of CP-31398

The primary mechanism attributed to CP-31398 is its ability to influence the conformation and stability of the p53 protein. This leads to the reactivation of its transcriptional functions and the induction of downstream anti-tumorigenic effects.

## Restoration of Wild-Type Conformation to Mutant p53

CP-31398 has been shown to restore a wild-type-associated epitope on the DNA-binding domain of mutant p53 proteins.[1] This conformational change is crucial for the protein to regain its ability to bind to the specific DNA response elements in the promoters of its target genes. Studies have demonstrated that CP-31398 can restore DNA-binding activity to p53 mutants such as R273H and R249S in a dose-dependent manner.[3][4]

## Stabilization of Wild-Type and Mutant p53

A key aspect of CP-31398's function is its ability to increase the cellular levels of both wild-type and mutant p53.[2][5] This stabilization is achieved, at least in part, by inhibiting the ubiquitination of p53.[1][6] By blocking the ubiquitin-proteasome degradation pathway for p53, CP-31398 leads to the accumulation of the protein in the nucleus, where it can exert its transcriptional activity. Notably, this inhibition of ubiquitination appears to occur without disrupting the physical interaction between p53 and its primary E3 ubiquitin ligase, MDM2.[1][6]

## The DNA Intercalation Controversy

While the model of direct p53 binding and conformational change is widely cited, some studies have suggested that CP-31398 may also function as a DNA intercalator.[7] This alternative mechanism proposes that the cellular effects of CP-31398 could be, in part, a consequence of inducing a DNA damage response, which would then lead to p53 stabilization through canonical pathways. However, it has been observed that CP-31398-induced p53 stabilization does not lead to the phosphorylation of p53 at serine 15 or 20, a hallmark of the DNA damage response, suggesting a distinct mechanism of action.[2][6] Further research is needed to fully elucidate the contribution of each proposed mechanism.

## Cellular Consequences of CP-31398 Treatment

The restoration of p53 function by CP-31398 triggers a cascade of downstream events that ultimately lead to the inhibition of cancer cell growth.

### Transcriptional Activation of p53 Target Genes

Upon stabilization and conformational rescue, p53 translocates to the nucleus and activates the transcription of its target genes. Key among these are:

- p21WAF1/CIP1: A cyclin-dependent kinase inhibitor that induces cell cycle arrest, primarily at the G1/S and G2/M checkpoints.[1][8][9]
- MDM2: As part of a negative feedback loop, p53 induces the expression of its own regulator, MDM2.[1][8]
- Pro-apoptotic Bcl-2 family members (e.g., Bax, PUMA): These proteins play a crucial role in initiating the mitochondrial pathway of apoptosis.[1][8][10][11]
- Apaf-1: A key component of the apoptosome, which is involved in the activation of caspase-9.[1][8]

### Cell Cycle Arrest

Treatment of cancer cells with CP-31398 leads to a dose-dependent cell cycle arrest.[1][8][12] In several cell lines, this manifests as an accumulation of cells in the G1 phase of the cell cycle.[8] For instance, in A204 rhabdomyosarcoma cells, lower concentrations of CP-31398 resulted in an up to 38% increase in the G1 population compared to control.[8]

## Induction of Apoptosis

CP-31398 is a potent inducer of apoptosis in cancer cells harboring either wild-type or mutant p53.<sup>[10][12]</sup> The primary mechanism of apoptosis induction is through the intrinsic, or mitochondrial, pathway.<sup>[8][10]</sup> This involves the translocation of p53 to the mitochondria, leading to a change in the mitochondrial membrane potential, the release of cytochrome c, and the subsequent activation of caspase-9 and caspase-3.<sup>[8][10][11]</sup>

## Data Presentation

The following tables summarize quantitative data from various studies on the effects of CP-31398.

Table 1: Effect of CP-31398 on Cell Cycle Distribution in A204 Rhabdomyosarcoma Cells

Treatment (24 hours)	% of Cells in G1 Phase (relative to control)
CP-31398 (low concentration)	Up to 38% increase

Data extracted from a study on rhabdomyosarcoma cells, which observed a dose-dependent accumulation of cells in the G1 phase at lower concentrations.<sup>[8]</sup>

Table 2: Effect of CP-31398 on p53 Downstream Target Gene Expression

Cell Line	p53 Status	Target Gene	Effect of CP-31398
A431 (human epidermoid carcinoma)	Mutant (R273H)	p21, mdm2, Bax	Upregulation
A204 (rhabdomyosarcoma)	Wild-type	p21, mdm2, puma	Upregulation
RD (rhabdomyosarcoma)	Mutant	p21, mdm2, puma	Upregulation
HCT116+/+ (colon carcinoma)	Wild-type	p21, Bax	Upregulation
MeWo (melanoma)	Mutant (single point mutation)	Bax, PUMA	Upregulation

This table compiles findings from multiple studies demonstrating the transcriptional activation of p53 target genes in various cancer cell lines following CP-31398 treatment.[\[1\]](#)[\[4\]](#)[\[8\]](#)[\[10\]](#)[\[11\]](#)

Table 3: Cellular Outcomes of CP-31398 Treatment in Various Cancer Cell Lines

Cell Line	p53 Status	Outcome
Nine human cancer cell lines	Wild-type, Mutant, or Null	6/9 underwent apoptosis, 2/9 underwent cell cycle arrest
A204 (rhabdomyosarcoma)	Wild-type	G1 cell cycle arrest and apoptosis
RD (rhabdomyosarcoma)	Mutant	Apoptosis
HCT116+/+ (colon carcinoma)	Wild-type	Apoptosis
MMRU (melanoma)	Wild-type	Apoptosis
MeWo (melanoma)	Mutant (single point mutation)	Apoptosis
Sk-mel-110 (melanoma)	Mutant (multiple mutations)	No apoptosis

This table summarizes the differential responses of various cancer cell lines to CP-31398, highlighting that the cellular outcome can be influenced by the p53 mutational status.[\[8\]](#)[\[11\]](#)[\[12\]](#)

## Experimental Protocols

The following are detailed methodologies for key experiments cited in the study of CP-31398.

### Western Blot Analysis for Protein Expression

Objective: To determine the levels of p53 and its downstream target proteins (e.g., p21, MDM2, Bax, cleaved caspases) following CP-31398 treatment.

Protocol:

- **Cell Culture and Treatment:** Plate cells at an appropriate density and treat with desired concentrations of CP-31398 or vehicle control for specified time periods.
- **Cell Lysis:** Wash cells with ice-cold PBS and lyse using RIPA buffer supplemented with protease and phosphatase inhibitors.
- **Protein Quantification:** Determine the protein concentration of the lysates using a BCA or Bradford protein assay.
- **Sample Preparation:** Mix equal amounts of protein (e.g., 20-50  $\mu$ g) with Laemmli sample buffer and boil at 95-100°C for 5-10 minutes.
- **SDS-PAGE:** Separate the protein samples on a polyacrylamide gel.
- **Protein Transfer:** Transfer the separated proteins to a PVDF or nitrocellulose membrane.
- **Blocking:** Block the membrane with 5% non-fat dry milk or BSA in TBST for 1 hour at room temperature.
- **Primary Antibody Incubation:** Incubate the membrane with the primary antibody specific for the protein of interest overnight at 4°C.
- **Washing:** Wash the membrane three times with TBST for 10 minutes each.

- Secondary Antibody Incubation: Incubate the membrane with an HRP-conjugated secondary antibody for 1 hour at room temperature.
- Washing: Wash the membrane three times with TBST for 10 minutes each.
- Detection: Detect the protein bands using an enhanced chemiluminescence (ECL) substrate and visualize using an imaging system.

## Quantitative Real-Time PCR (qRT-PCR) for Gene Expression Analysis

Objective: To measure the mRNA levels of p53 target genes (e.g., CDKN1A (p21), MDM2, BAX, PUMA) after CP-31398 treatment.

Protocol:

- Cell Culture and Treatment: Treat cells with CP-31398 as described for Western blotting.
- RNA Extraction: Isolate total RNA from the cells using a commercial RNA extraction kit.
- RNA Quantification and Quality Control: Determine the concentration and purity of the RNA using a spectrophotometer.
- cDNA Synthesis: Synthesize first-strand cDNA from the total RNA using a reverse transcriptase kit.
- qRT-PCR: Perform qRT-PCR using a SYBR Green or TaqMan-based assay with gene-specific primers for the target genes and a housekeeping gene (e.g., GAPDH, ACTB) for normalization.
- Data Analysis: Calculate the relative fold change in gene expression using the  $\Delta\Delta C_t$  method.

## Flow Cytometry for Cell Cycle Analysis

Objective: To determine the effect of CP-31398 on cell cycle distribution.

Protocol:

- **Cell Culture and Treatment:** Treat cells with CP-31398 as previously described.
- **Cell Harvesting:** Harvest the cells by trypsinization and wash with PBS.
- **Fixation:** Fix the cells in ice-cold 70% ethanol while vortexing gently and store at -20°C overnight.
- **Staining:** Wash the fixed cells with PBS and resuspend in a staining solution containing propidium iodide (PI) and RNase A.
- **Data Acquisition:** Analyze the stained cells using a flow cytometer, acquiring data for at least 10,000 events per sample.
- **Data Analysis:** Analyze the DNA content histograms using cell cycle analysis software to determine the percentage of cells in the G0/G1, S, and G2/M phases.

## Chromatin Immunoprecipitation (ChIP) Assay

**Objective:** To determine if CP-31398 treatment enhances the binding of p53 to the promoter regions of its target genes.

**Protocol:**

- **Cross-linking:** Treat cells with CP-31398, followed by cross-linking with formaldehyde to fix protein-DNA complexes.
- **Cell Lysis and Chromatin Shearing:** Lyse the cells and shear the chromatin to fragments of 200-1000 bp using sonication or enzymatic digestion.
- **Immunoprecipitation:** Incubate the sheared chromatin with an antibody specific for p53 or a control IgG overnight at 4°C.
- **Immune Complex Capture:** Capture the antibody-protein-DNA complexes using protein A/G-agarose or magnetic beads.
- **Washing:** Wash the beads to remove non-specific binding.

- Elution and Reverse Cross-linking: Elute the complexes and reverse the cross-links by heating.
- DNA Purification: Purify the DNA using a DNA purification kit.
- Analysis: Analyze the purified DNA by qPCR using primers specific for the p53 response elements in the promoter regions of target genes (e.g., p21).

## Visualization of Signaling Pathways and Experimental Workflows

The following diagrams, generated using the DOT language, illustrate key pathways and workflows related to the action of CP-31398.

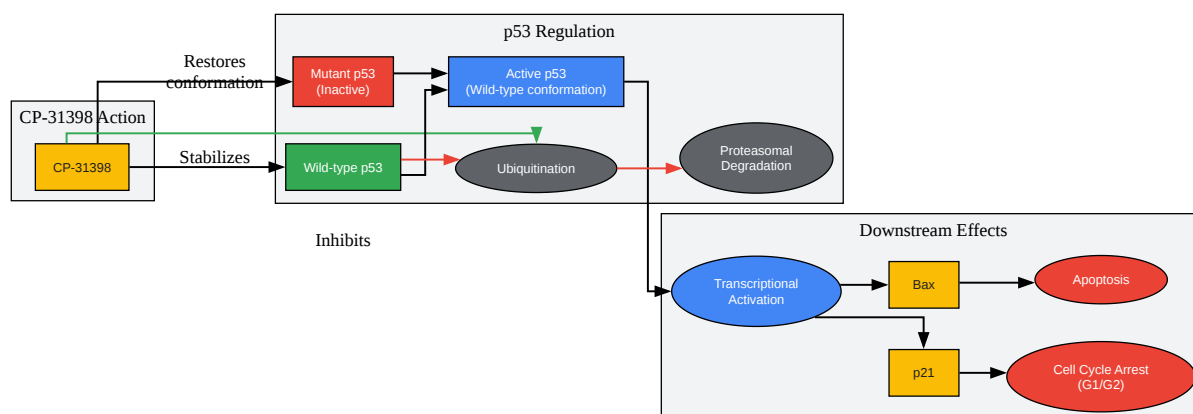

[Click to download full resolution via product page](#)

### CP-31398 Mechanism of Action

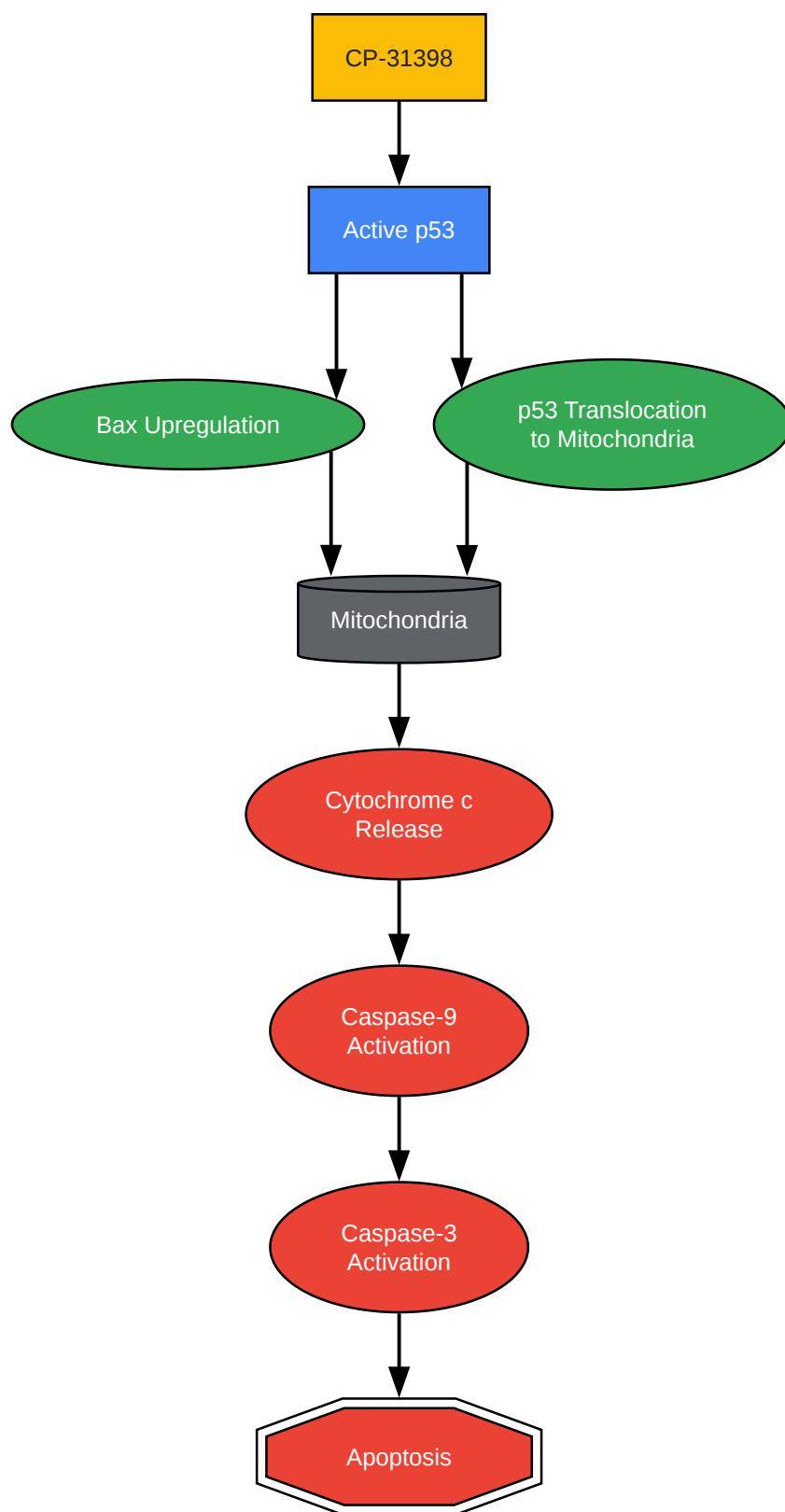

[Click to download full resolution via product page](#)

### Mitochondrial Apoptosis Pathway

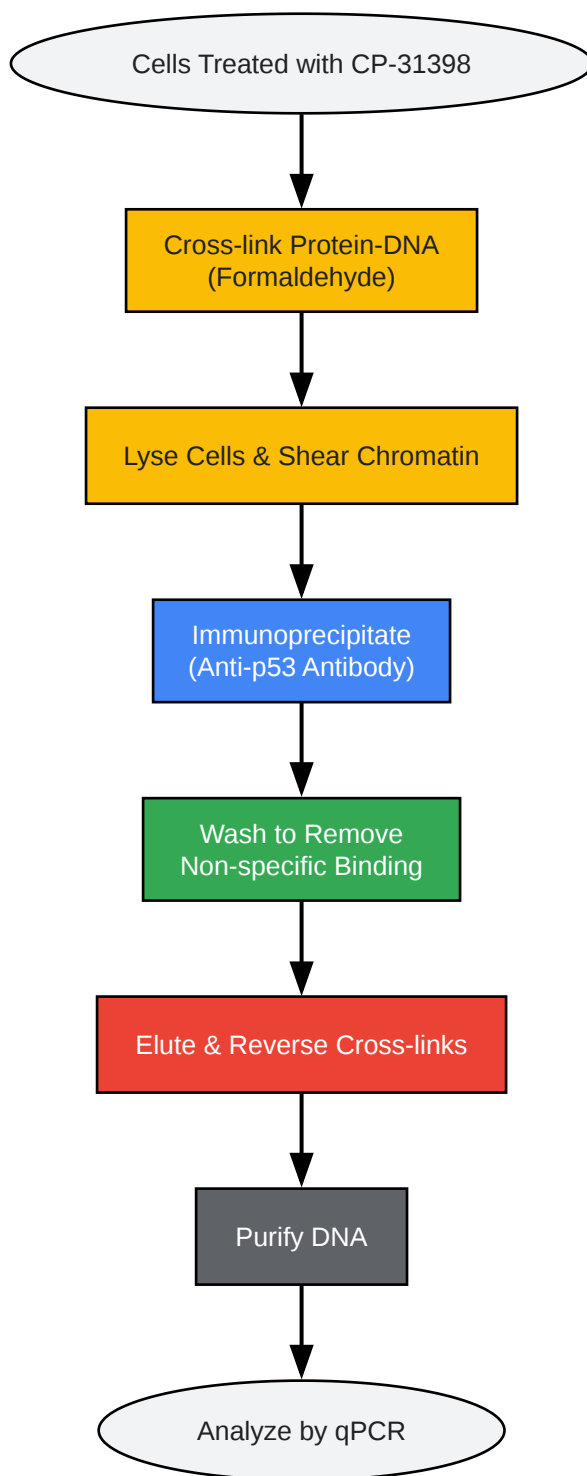

[Click to download full resolution via product page](#)

Chromatin Immunoprecipitation Workflow

## Conclusion

CP-31398 represents a pioneering effort in the pharmacological reactivation of p53. Its ability to restore wild-type function to mutant p53 and stabilize the wild-type protein underscores the therapeutic potential of targeting this critical tumor suppressor. By inducing the transcription of key target genes, CP-31398 effectively triggers cell cycle arrest and apoptosis in a variety of cancer cell models. While the precise molecular interaction of CP-31398 with p53 and DNA remains a subject of some debate, its profound biological effects are well-documented. This technical guide provides a comprehensive overview of the current understanding of CP-31398's role in restoring p53 function, offering a valuable resource for the ongoing research and development of novel cancer therapeutics targeting the p53 pathway. Further investigation into the nuances of its mechanism and the determinants of cellular response will be crucial in optimizing its potential clinical applications.

#### *Need Custom Synthesis?*

*BenchChem offers custom synthesis for rare earth carbides and specific isotopic labeling.*

*Email: [info@benchchem.com](mailto:info@benchchem.com) or [Request Quote Online](#).*

## References

- [1. CP-31398 restores mutant p53 tumor suppressor function and inhibits UVB-induced skin carcinogenesis in mice - PMC \[pmc.ncbi.nlm.nih.gov\]](#)
- [2. Targeting wild-type and mutant p53 with small molecule CP-31398 blocks the growth of rhabdomyosarcoma by inducing reactive oxygen species-dependent apoptosis - PubMed \[pubmed.ncbi.nlm.nih.gov\]](#)
- [3. CP-31398 restores DNA-binding activity to mutant p53 in vitro but does not affect p53 homologs p63 and p73 - PubMed \[pubmed.ncbi.nlm.nih.gov\]](#)
- [4. JCI - CP-31398 restores mutant p53 tumor suppressor function and inhibits UVB-induced skin carcinogenesis in mice \[jci.org\]](#)
- [5. Stabilization of p53 by CP-31398 Inhibits Ubiquitination without Altering Phosphorylation at Serine 15 or 20 or MDM2 Binding - PMC \[pmc.ncbi.nlm.nih.gov\]](#)
- [6. Stabilization of p53 by CP-31398 inhibits ubiquitination without altering phosphorylation at serine 15 or 20 or MDM2 binding - PubMed \[pubmed.ncbi.nlm.nih.gov\]](#)
- [7. CP-31398, a putative p53-stabilizing molecule tested in mammalian cells and in yeast for its effects on p53 transcriptional activity - PMC \[pmc.ncbi.nlm.nih.gov\]](#)

- 8. Targeting wild-type and mutant p53 with small molecule CP-31398 blocks the growth of rhabdomyosarcoma by inducing ROS-dependent apoptosis - PMC [pmc.ncbi.nlm.nih.gov]
- 9. A p53-stabilizing agent, CP-31398, induces p21 expression with increased G2/M phase through the YY1 transcription factor in esophageal carcinoma defective of the p53 pathway - PMC [pmc.ncbi.nlm.nih.gov]
- 10. The p53 stabilizing compound CP-31398 induces apoptosis by activating the intrinsic Bax/mitochondrial/caspase-9 pathway - PubMed [pubmed.ncbi.nlm.nih.gov]
- 11. Mutant p53 melanoma cell lines respond differently to CP-31398-induced apoptosis - PubMed [pubmed.ncbi.nlm.nih.gov]
- 12. The mutant p53-conformation modifying drug, CP-31398, can induce apoptosis of human cancer cells and can stabilize wild-type p53 protein - PubMed [pubmed.ncbi.nlm.nih.gov]
- To cite this document: BenchChem. [The Role of CP-31398 in Restoring p53 Function: A Technical Guide]. BenchChem, [2026]. [Online PDF]. Available at: [https://www.benchchem.com/product/b1669482/docs#the-role-of-cp-31398-in-restoring-p53-function-a-technical-guide]

---

### Disclaimer & Data Validity:

The information provided in this document is for Research Use Only (RUO) and is strictly not intended for diagnostic or therapeutic procedures. While BenchChem strives to provide accurate protocols, we make no warranties, express or implied, regarding the fitness of this product for every specific experimental setup.

**Technical Support:** The protocols provided are for reference purposes. Unsure if this reagent suits your experiment?

**Need Industrial/Bulk Grade?** [Request Custom Synthesis Quote](#)

## BenchChem

Our mission is to be the trusted global source of essential and advanced chemicals, empowering scientists and researchers to drive progress in science and industry.

### Contact

Address: 3281 E Guasti Rd  
Ontario, CA 91761, United States  
Phone: (601) 213-4426  
Email: [info@benchchem.com](mailto:info@benchchem.com)

Contact our Ph.D. Support Team for a compatibility check