

# Mitigating batch-to-batch variability of D4476

**Author:** BenchChem Technical Support Team. **Date:** December 2025

## Compound of Interest

**Compound Name:** 4-(4-(2,3-dihydrobenzo(1,4)dioxin-6-yl)-5-pyridin-2-yl-1H-imidazol-2-yl)benzamide

**Cat. No.:** B1669709

[Get Quote](#)

## Technical Support Center: D4476

This technical support center provides troubleshooting guides and frequently asked questions (FAQs) to assist researchers, scientists, and drug development professionals in mitigating batch-to-batch variability and ensuring consistent results when using the Casein Kinase 1 (CK1) inhibitor, D4476.

## Frequently Asked Questions (FAQs)

Q1: What is D4476 and what is its primary mechanism of action?

D4476 is a cell-permeable, potent, and selective inhibitor of Casein Kinase 1 (CK1).<sup>[1][2]</sup> It functions as an ATP-competitive inhibitor, meaning it binds to the ATP-binding pocket of the kinase, preventing the transfer of phosphate to its substrates.

Q2: What are the primary targets of D4476?

The primary target of D4476 is Casein Kinase 1 (CK1).<sup>[1][2]</sup> It also exhibits inhibitory activity against the TGF- $\beta$  type-I receptor, ALK5.<sup>[2][3]</sup>

Q3: What are the recommended storage and solubility guidelines for D4476?

Proper storage and handling are critical for maintaining the stability and activity of D4476.

Parameter	Recommendation	Source
Storage Temperature	Store at +4°C for short-term and -20°C for long-term.	[4]
Stability	≥ 4 years when stored at -20°C.	[4]
Solubility	Soluble in DMSO (up to 100 mM) and ethanol (up to 50 mM).	[3]

Q4: What are the known IC50 values for D4476 against its primary targets?

The half-maximal inhibitory concentration (IC50) values for D4476 can vary depending on the specific isoform and assay conditions.

Target	IC50 Value	Source
Casein Kinase 1 (CK1δ)	0.3 μM	[1][2]
Casein Kinase 1 (from <i>S. pombe</i> )	0.2 μM	[2]
ALK5 (TGF-βRI)	0.5 μM	[2][3]
SAPK2/p38	>20-fold selectivity over this target	[3]

## Troubleshooting Guide: Mitigating Batch-to-Batch Variability

Inconsistent results between different batches of D4476 can be a significant source of experimental variability. This guide provides a systematic approach to troubleshooting these issues.

Q1: I'm observing a decrease in the expected inhibitory effect with a new batch of D4476. What should I do?

A decrease in potency is a common issue. The following workflow can help identify the root cause.

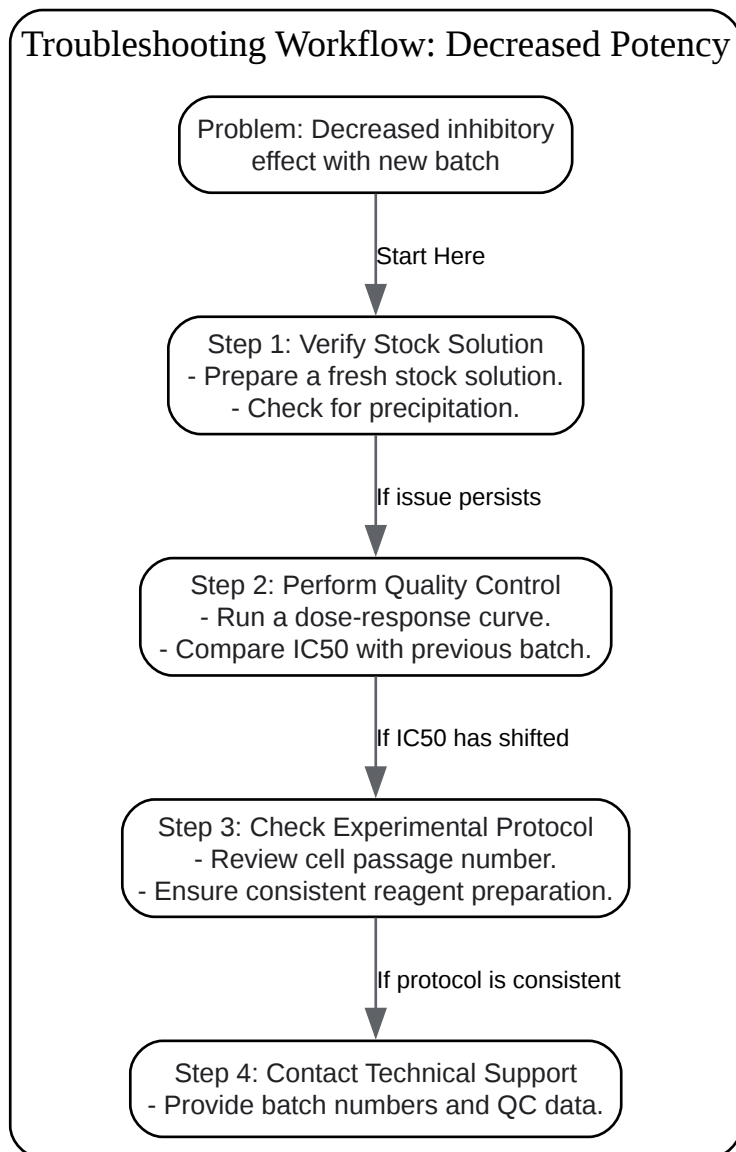

[Click to download full resolution via product page](#)

Caption: Troubleshooting workflow for decreased D4476 potency.

Potential Causes and Solutions:

- Compound Degradation:

- Cause: Improper storage (e.g., exposure to light or moisture, frequent freeze-thaw cycles).
- Solution: Always store D4476 according to the manufacturer's recommendations (+4°C for short-term, -20°C for long-term).[4] Aliquot stock solutions to minimize freeze-thaw cycles.
- Inaccurate Stock Concentration:
  - Cause: Errors in weighing the compound or dissolving it in the solvent. Precipitation of the compound out of solution.
  - Solution: Prepare fresh stock solutions. Ensure the compound is fully dissolved. If precipitation is observed in a frozen stock, gently warm and vortex to redissolve before use.
- Variations in Experimental Procedure:
  - Cause: Inconsistencies in cell density, passage number, incubation times, or reagent concentrations.
  - Solution: Standardize all experimental parameters. Use cells within a consistent passage number range and ensure all reagents are prepared fresh and consistently.

Q2: My new batch of D4476 is showing unexpected off-target effects or increased cytotoxicity. How can I address this?

Increased off-target effects or cytotoxicity may indicate the presence of impurities or a higher effective concentration than intended.

Potential Causes and Solutions:

- Batch-Specific Impurities:
  - Cause: Different synthesis lots may have varying impurity profiles.
  - Solution: Request a certificate of analysis (CoA) for each new batch to compare purity levels. If significant differences are noted, consider testing a different batch or contacting the supplier.

- Solvent Effects:
  - Cause: The solvent (e.g., DMSO) itself can have cytotoxic effects at higher concentrations.
  - Solution: Ensure the final concentration of the solvent in your experimental media is consistent and below the threshold for cytotoxicity for your cell line (typically <0.1%). Run a solvent-only control.
- Incorrect Dosing:
  - Cause: Errors in calculating dilutions from the stock solution.
  - Solution: Double-check all calculations for preparing working solutions. Perform a new dose-response experiment to determine the optimal concentration for the new batch.

## Signaling Pathways and Experimental Protocols

### D4476 Signaling Pathways

D4476 primarily targets CK1, which is involved in multiple signaling pathways, including the Wnt/ $\beta$ -catenin pathway. It also inhibits ALK5, a key receptor in the TGF- $\beta$  pathway.

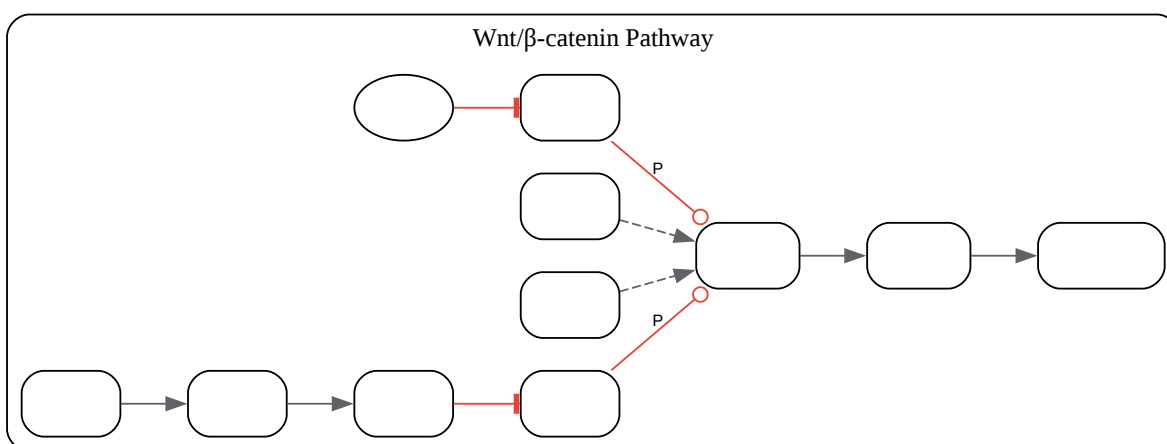

[Click to download full resolution via product page](#)

Caption: D4476 inhibits CK1 in the Wnt/ $\beta$ -catenin pathway.

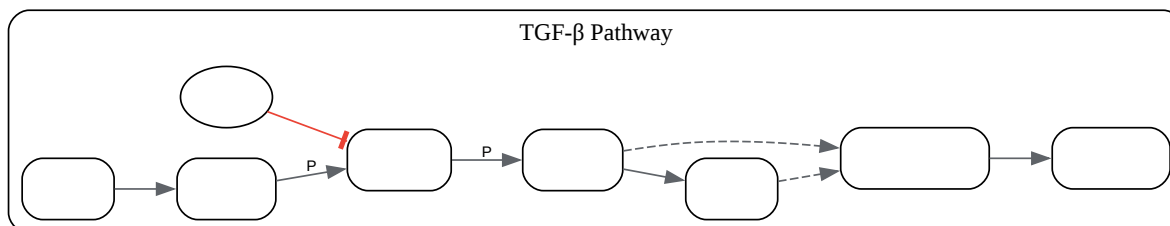

[Click to download full resolution via product page](#)

Caption: D4476 inhibits ALK5 in the TGF- $\beta$  signaling pathway.

## Recommended Experimental Protocol: Western Blot for Phospho-FOXO1a

This protocol describes a method to assess the inhibitory activity of D4476 by measuring the phosphorylation of a downstream target, FOXO1a. D4476 has been shown to specifically inhibit the phosphorylation of endogenous FOXO1a on Ser322 and Ser325.[2]

## Experimental Workflow: Western Blot for p-FOXO1a

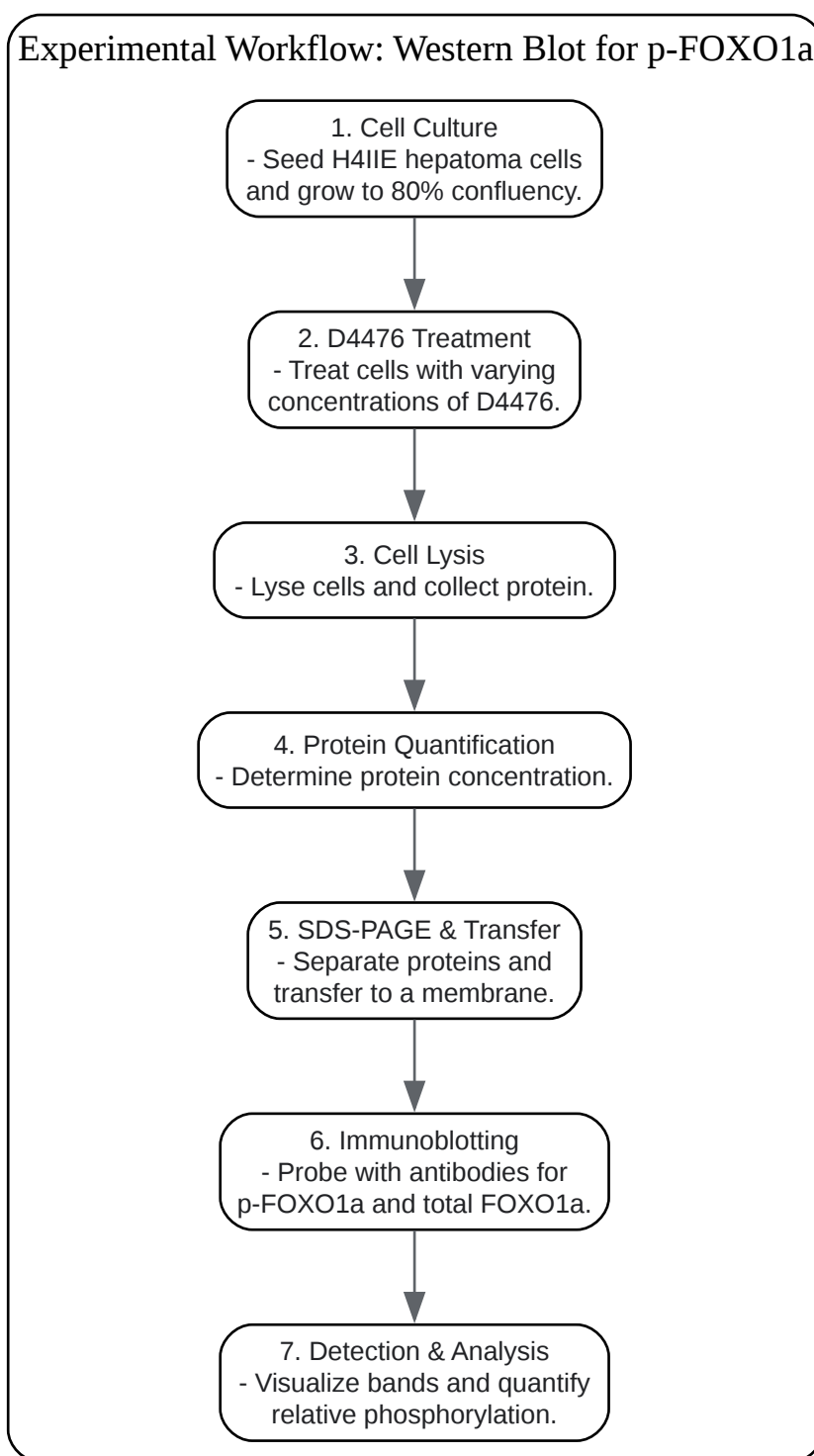

[Click to download full resolution via product page](#)

Caption: Workflow for assessing D4476 activity via Western Blot.

Detailed Steps:

- Cell Culture:
  - Culture H4IIE hepatoma cells (or other suitable cell line) in the recommended medium until they reach approximately 80% confluency.
- D4476 Treatment:
  - Prepare a series of D4476 dilutions in culture medium from a fresh stock solution. A typical concentration range to test would be 0.1  $\mu$ M to 10  $\mu$ M.
  - Include a vehicle control (e.g., DMSO) at the same final concentration as the highest D4476 treatment.
  - Replace the culture medium with the D4476-containing medium and incubate for the desired time (e.g., 1-24 hours).
- Cell Lysis:
  - Wash the cells with ice-cold PBS.
  - Lyse the cells in a suitable lysis buffer (e.g., RIPA buffer) containing protease and phosphatase inhibitors.
  - Collect the cell lysates and clarify by centrifugation.
- Protein Quantification:
  - Determine the protein concentration of each lysate using a standard protein assay (e.g., BCA assay).
- SDS-PAGE and Western Blot:
  - Load equal amounts of protein from each sample onto an SDS-PAGE gel.
  - Separate the proteins by electrophoresis.
  - Transfer the separated proteins to a PVDF or nitrocellulose membrane.



- Immunoblotting:
  - Block the membrane with a suitable blocking buffer (e.g., 5% BSA or non-fat milk in TBST).
  - Incubate the membrane with a primary antibody specific for phosphorylated FOXO1a (e.g., p-FOXO1a Ser322/325).
  - Wash the membrane and incubate with an appropriate HRP-conjugated secondary antibody.
  - For a loading control, strip the membrane and re-probe with an antibody for total FOXO1a.
- Detection and Analysis:
  - Detect the protein bands using an enhanced chemiluminescence (ECL) substrate and an imaging system.
  - Quantify the band intensities and normalize the phosphorylated FOXO1a signal to the total FOXO1a signal to determine the extent of inhibition.

#### *Need Custom Synthesis?*

*BenchChem offers custom synthesis for rare earth carbides and specific isotopic labeling.*

*Email: [info@benchchem.com](mailto:info@benchchem.com) or [Request Quote Online](#).*

## References

- 1. medchemexpress.com [medchemexpress.com]
- 2. selleckchem.com [selleckchem.com]
- 3. D 4476 | Casein Kinase 1 | Tocris Bioscience [tocris.com]
- 4. caymanchem.com [caymanchem.com]
- To cite this document: BenchChem. [Mitigating batch-to-batch variability of D4476]. BenchChem, [2025]. [Online PDF]. Available at: [https://www.benchchem.com/product/b1669709#mitigating-batch-to-batch-variability-of-d4476]

**Disclaimer & Data Validity:**

The information provided in this document is for Research Use Only (RUO) and is strictly not intended for diagnostic or therapeutic procedures. While BenchChem strives to provide accurate protocols, we make no warranties, express or implied, regarding the fitness of this product for every specific experimental setup.

**Technical Support:** The protocols provided are for reference purposes. Unsure if this reagent suits your experiment? [[Contact our Ph.D. Support Team for a compatibility check](#)]

**Need Industrial/Bulk Grade?** [Request Custom Synthesis Quote](#)

## BenchChem

Our mission is to be the trusted global source of essential and advanced chemicals, empowering scientists and researchers to drive progress in science and industry.

### Contact

Address: 3281 E Guasti Rd

Ontario, CA 91761, United States

Phone: (601) 213-4426

Email: [info@benchchem.com](mailto:info@benchchem.com)