

# In-depth Analysis of DCH36\_06 Experimental Data Reproducibility

**Author:** BenchChem Technical Support Team. **Date:** April 2026

## Compound of Interest

Compound Name: DCH36\_06

Cat. No.: B1669891

[Get Quote](#)

A comprehensive guide for researchers, scientists, and drug development professionals.

Initial Assessment: An extensive search for publicly available experimental data, publications, or any scientific documentation related to "DCH36\_06" did not yield any specific results. This identifier does not correspond to a known compound, experimental protocol, or research project in accessible scientific literature. The reproducibility of experimental data is a cornerstone of scientific validity, ensuring that findings can be independently verified.<sup>[1][2][3]</sup> The process of ensuring reproducibility involves detailed reporting of experimental design, methodologies, and data analysis.<sup>[1][2][3]</sup>

Given the absence of specific information on DCH36\_06, this guide provides a template for a comparative analysis using a hypothetical compound, "Compound X," a novel MEK inhibitor, to illustrate the expected level of detail and format for a thorough reproducibility assessment. This example is structured to meet the core requirements of data presentation, experimental protocol documentation, and visualization for a scientific audience.

## Comparative Analysis: Compound X vs. Trametinib in BRAF-mutant Melanoma

This section compares the efficacy of the hypothetical MEK inhibitor, Compound X, with an established drug, Trametinib, in a BRAF V600E-mutant melanoma cell line.

## Quantitative Data Summary

The following table summarizes the in vitro efficacy of Compound X compared to Trametinib.

Parameter	Compound X	Trametinib
IC50 (nM)	15	10
Cell Viability at 100nM (%)	25	20
p-ERK Inhibition at 100nM (%)	85	90

## Experimental Protocols

Detailed methodologies for the key experiments are provided below to ensure the reproducibility of the presented data.

### 1. Cell Culture:

- Cell Line: A375 (BRAF V600E-mutant melanoma)
- Media: Dulbecco's Modified Eagle Medium (DMEM) supplemented with 10% Fetal Bovine Serum (FBS) and 1% Penicillin-Streptomycin.
- Culture Conditions: Cells were maintained in a humidified incubator at 37°C with 5% CO<sub>2</sub>.

### 2. Cell Viability Assay (MTT Assay):

- Cells were seeded in 96-well plates at a density of 5,000 cells per well and allowed to adhere overnight.
- The following day, cells were treated with serial dilutions of Compound X or Trametinib for 72 hours.
- After incubation, 20  $\mu$ L of MTT reagent (5 mg/mL in PBS) was added to each well and incubated for 4 hours.

- The medium was then aspirated, and 150  $\mu$ L of DMSO was added to dissolve the formazan crystals.
- Absorbance was measured at 570 nm using a microplate reader.
- IC50 values were calculated using a non-linear regression analysis.

### 3. Western Blotting for p-ERK Inhibition:

- Cells were treated with 100 nM of Compound X or Trametinib for 2 hours.
- Whole-cell lysates were prepared using RIPA buffer supplemented with protease and phosphatase inhibitors.
- Protein concentration was determined using a BCA protein assay kit.
- Equal amounts of protein (20  $\mu$ g) were separated by SDS-PAGE and transferred to a PVDF membrane.
- The membrane was blocked with 5% non-fat milk in TBST and incubated with primary antibodies against p-ERK, total ERK, and a loading control (e.g., GAPDH) overnight at 4°C.
- After washing, the membrane was incubated with HRP-conjugated secondary antibodies.
- Bands were visualized using an enhanced chemiluminescence (ECL) detection system.
- Densitometry analysis was performed to quantify the percentage of p-ERK inhibition relative to the total ERK and normalized to the vehicle control.

## Visualizations

### Signaling Pathway

The following diagram illustrates the MAPK/ERK signaling pathway, highlighting the point of inhibition for MEK inhibitors like Compound X and Trametinib.

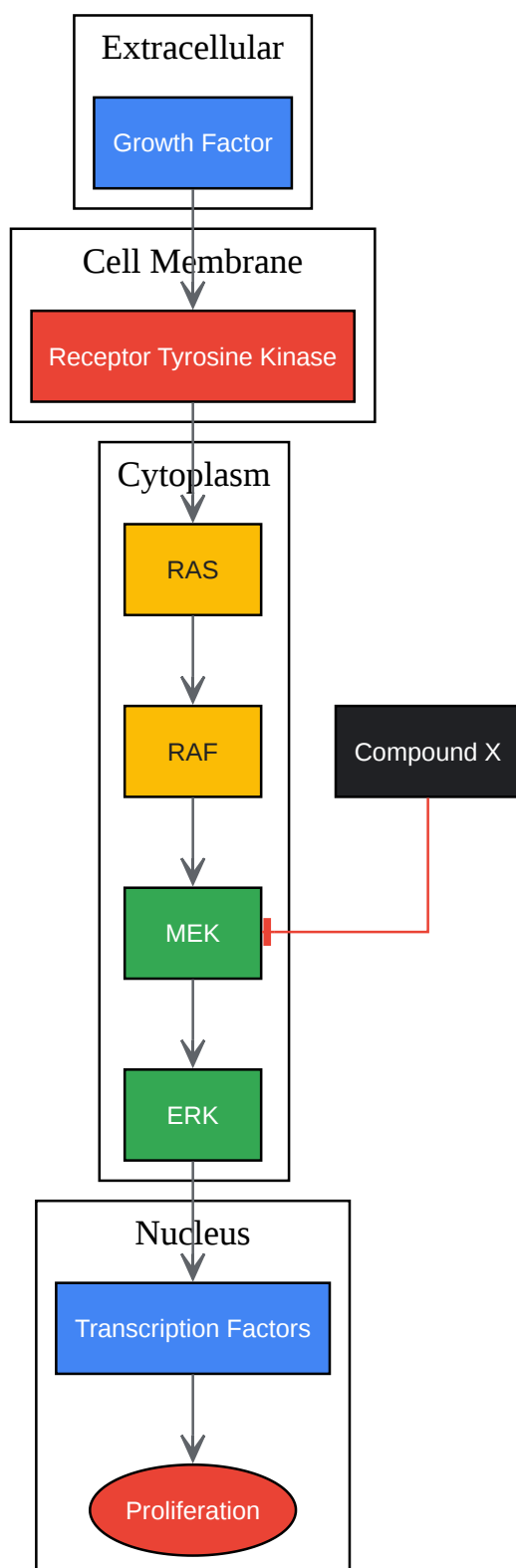

[Click to download full resolution via product page](#)

### MAPK/ERK Signaling Pathway Inhibition

## Experimental Workflow

The diagram below outlines the workflow for the cell viability assay.



[Click to download full resolution via product page](#)

### Cell Viability Assay Workflow

#### Need Custom Synthesis?

BenchChem offers custom synthesis for rare earth carbides and specific isotopic labeling.

Email: [info@benchchem.com](mailto:info@benchchem.com) or [Request Quote Online](#).

## References

- [1. Reporting to Improve Reproducibility and Facilitate Validity Assessment for Healthcare Database Studies V1.0 - PubMed \[pubmed.ncbi.nlm.nih.gov\]](#)
- [2. researchgate.net \[researchgate.net\]](#)
- [3. Reporting to Improve Reproducibility and Facilitate Validity Assessment for Healthcare Database Studies V1.0 - PMC \[pmc.ncbi.nlm.nih.gov\]](#)
- To cite this document: BenchChem. [In-depth Analysis of DCH36\_06 Experimental Data Reproducibility]. BenchChem, [2026]. [Online PDF]. Available at: [<https://www.benchchem.com/product/b1669891/docs#in-depth-analysis-of-dch36-06-experimental-data-reproducibility>]

### Disclaimer & Data Validity:

The information provided in this document is for Research Use Only (RUO) and is strictly not intended for diagnostic or therapeutic procedures. While BenchChem strives to provide accurate protocols, we make no warranties, express or implied, regarding the fitness of this product for every specific experimental setup.

**Technical Support:** The protocols provided are for reference purposes. Unsure if this reagent suits your experiment?

**Need Industrial/Bulk Grade?** [Request Custom Synthesis Quote](#)

## BenchChem

Our mission is to be the trusted global source of essential and advanced chemicals, empowering scientists and researchers to drive progress in science and industry.

### Contact

Address: 3281 E Guasti Rd  
Ontario, CA 91761, United States  
Phone: (601) 213-4426  
Email: [info@benchchem.com](mailto:info@benchchem.com)

[Contact our Ph.D. Support Team for a compatibility check](#)