

Validating the Antiarrhythmic Effects of Budiodarone In Vivo: A Comparative Guide

Author: BenchChem Technical Support Team. **Date:** April 2026

Compound of Interest

Compound Name: *Budiodarone*

CAS No.: *335148-45-3*

Cat. No.: *B1668027*

[Get Quote](#)

For Researchers, Scientists, and Drug Development Professionals

This guide provides an objective comparison of the in vivo antiarrhythmic effects of **Budiodarone** against its structural analog, Amiodarone, and a common alternative, Dronedarone. The information is compiled from available preclinical and clinical studies to support research and development in the field of cardiac arrhythmia.

Executive Summary

Budiodarone (ATI-2042) is a promising antiarrhythmic agent designed as an analog of Amiodarone with a potentially improved safety profile. Like Amiodarone and Dronedarone, **Budiodarone** is a multi-channel blocker, targeting key ion channels involved in the cardiac action potential. Preclinical studies have suggested that **Budiodarone** possesses potent antiarrhythmic effects, particularly in ventricular tachycardia. However, detailed quantitative data from in vivo preclinical models are not extensively available in the public domain. This guide summarizes the existing data for Amiodarone and Dronedarone to provide a benchmark for the evaluation of **Budiodarone** and presents the available information on **Budiodarone's** preclinical and clinical performance.

Comparative Analysis of In Vivo Efficacy

The following tables summarize quantitative data from in vivo studies on the electrophysiological and antiarrhythmic effects of Amiodarone and Dronedarone. Due to the limited availability of public preclinical data for **Budiodarone**, a direct quantitative comparison is not currently possible.

Table 1: In Vivo Electrophysiological Effects on Ventricular Tissue

Parameter	Budiodarone (ATI-2042)	Amiodarone	Dronedarone	Animal Model
Action Potential Duration at 90% Repolarization (APD90)	Increased (qualitative)	↑ by ~21%	↑ by ~31%	Canine Chronic AV Block
Effective Refractory Period (ERP)	Increased (qualitative)	Significantly Prolonged	Significantly Prolonged	Canine
QT Interval	No significant change reported in a human study[1]	↑ by ~21%	↑ by ~31%	Canine Chronic AV Block
Heart Rate	Dose-dependent decrease[2]	↓ by ~15-20%	Dose-dependent decrease	Canine

Table 2: Efficacy in In Vivo Arrhythmia Models

Arrhythmia Model	Budiodarone (ATI-2042)	Amiodarone	Dronedarone
Ischemia-Reperfusion Induced Ventricular Fibrillation	Potent inhibitory effects reported	Effective in reducing incidence	More effective than Amiodarone in some models[3]
Atrial Fibrillation (AF) Burden (Clinical Data)	↓ by 54-75% (400-600 mg bid)[2]	Highly effective in maintaining sinus rhythm	Less effective than Amiodarone for AF recurrence[4]

Experimental Protocols

Detailed methodologies for key in vivo experiments are crucial for the interpretation and replication of findings. Below are representative protocols for assessing the antiarrhythmic effects of compounds in established animal models.

Canine Chronic Atrioventricular (AV) Block Model for Proarrhythmia Assessment

This model is utilized to evaluate the potential of a drug to induce Torsade de Pointes (TdP).

- **Animal Model:** Adult mongrel dogs are used. Complete AV block is surgically induced by radiofrequency ablation of the bundle of His. This leads to a chronic, stable, low heart rate, which is a known risk factor for TdP.
- **Drug Administration:** Amiodarone (e.g., 3 and 30 mg/kg) or a comparator drug is administered orally.
- **Electrophysiological Monitoring:** Continuous ECG monitoring is performed to record heart rate, QT interval, and the occurrence of ventricular arrhythmias, including TdP. Intracardiac electrograms can be recorded via implanted electrodes to measure parameters like APD90 and ERP.
- **Data Analysis:** Changes in electrophysiological parameters from baseline are calculated. The incidence and duration of TdP and other ventricular arrhythmias are quantified.

Ischemia-Reperfusion Arrhythmia Model in Rats

This model assesses the efficacy of a drug in preventing arrhythmias associated with myocardial infarction.

- **Animal Model:** Male Wistar rats are anesthetized.
- **Surgical Procedure:** A ligature is placed around the left anterior descending (LAD) coronary artery.
- **Induction of Ischemia and Reperfusion:** The LAD is occluded for a set period (e.g., 5 minutes) to induce ischemia, followed by a reperfusion period (e.g., 5 minutes) where the occlusion is released.
- **Drug Administration:** The test compound (e.g., Dronedarone) or vehicle is administered intravenously before the ischemic period.
- **Arrhythmia Assessment:** A continuous ECG is recorded throughout the procedure. The incidence and duration of ventricular tachycardia (VT) and ventricular fibrillation (VF) are determined.
- **Data Analysis:** The antiarrhythmic effect is quantified by comparing the arrhythmia scores (based on the incidence and duration of VT and VF) between the drug-treated and vehicle-treated groups.

Signaling Pathways and Mechanisms of Action

The antiarrhythmic effects of **Budiodarone**, Amiodarone, and Dronedarone stem from their ability to modulate multiple cardiac ion channels. This multi-channel blockade leads to a prolongation of the cardiac action potential and refractory period, thereby suppressing arrhythmias.

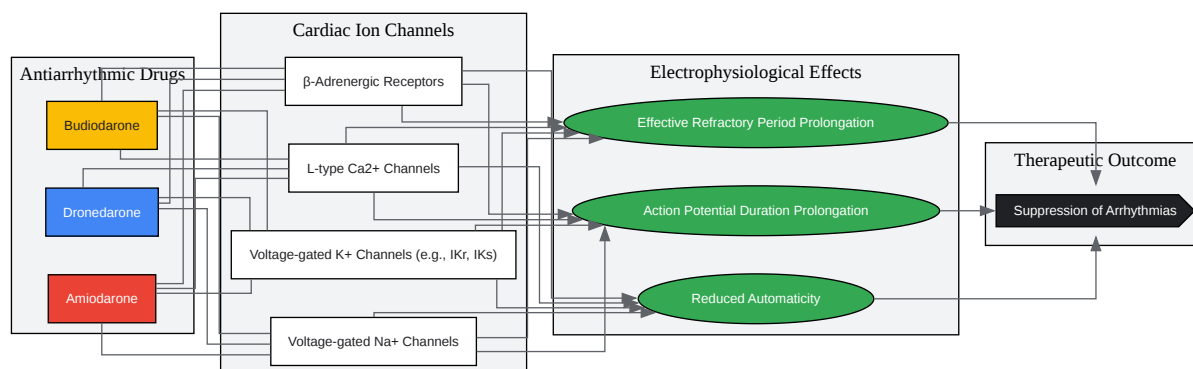

[Click to download full resolution via product page](#)

Caption: Mechanism of action for **Budiodarone** and its comparators.

The diagram above illustrates the primary mechanism of action for **Budiodarone**, Amiodarone, and Dronedarone, which involves the blockade of multiple cardiac ion channels and receptors. This leads to key electrophysiological changes that result in the suppression of arrhythmias.

Experimental Workflow

The following diagram outlines a typical workflow for the in vivo evaluation of a novel antiarrhythmic compound.

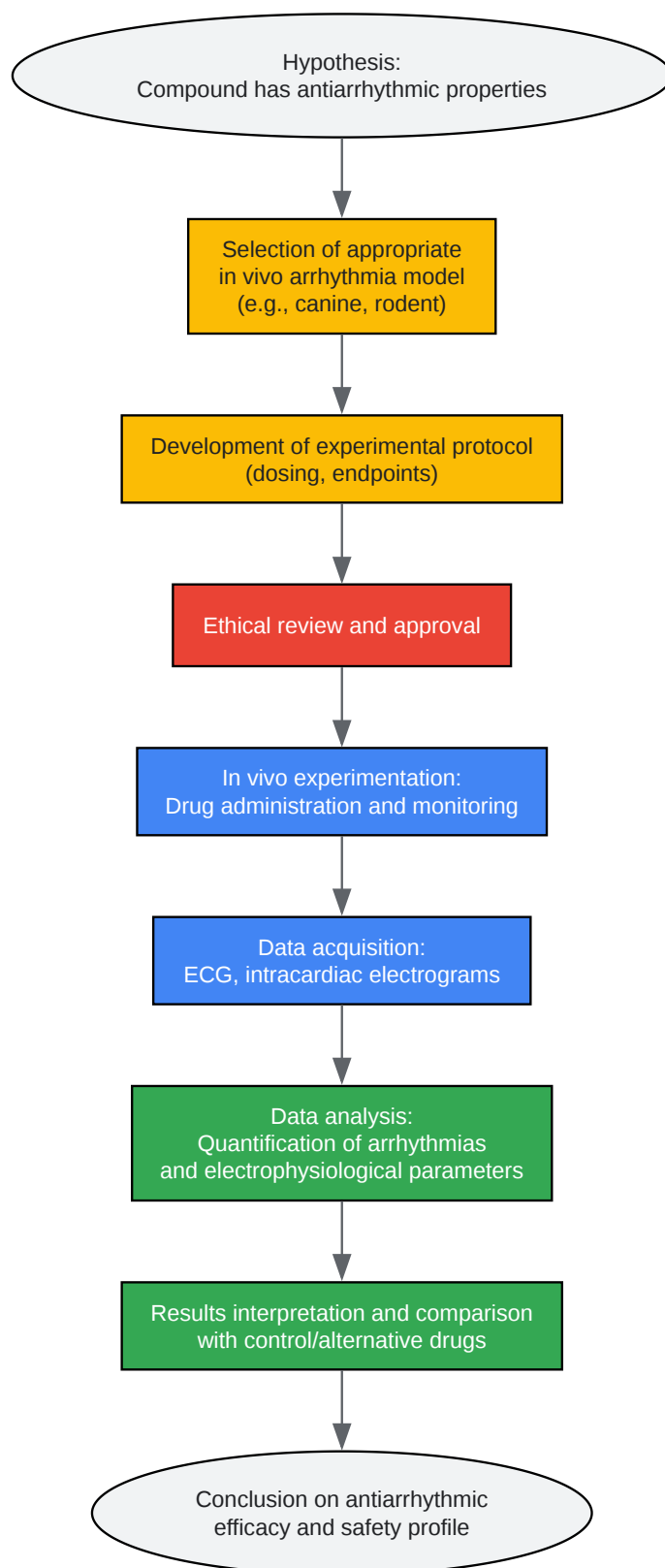

[Click to download full resolution via product page](#)

Caption: A typical workflow for in vivo antiarrhythmic drug validation.

This workflow highlights the key stages involved in the preclinical validation of an antiarrhythmic drug, from hypothesis generation to the final conclusion on its efficacy and safety.

Conclusion

Budiodarone holds considerable promise as a next-generation antiarrhythmic agent, potentially offering a safety advantage over Amiodarone due to its shorter half-life and different metabolic pathway. While direct, quantitative comparisons from in vivo preclinical studies are limited in the public domain, the available information suggests a similar multi-channel blocking mechanism and potent antiarrhythmic effects. Further publication of detailed preclinical data will be crucial for a comprehensive head-to-head comparison with established alternatives like Amiodarone and Dronedarone. This guide provides a framework for such a comparison, summarizing the available evidence and outlining the standard experimental approaches used in the field.

Need Custom Synthesis?

BenchChem offers custom synthesis for rare earth carbides and specific isotopic labeling.

Email: info@benchchem.com or [Request Quote Online](#).

References

- [1. A preliminary assessment of the effects of ATI-2042 in subjects with paroxysmal atrial fibrillation using implanted pacemaker methodology - PMC \[pmc.ncbi.nlm.nih.gov\]](#)
- [2. Budiodarone - Wikipedia \[en.wikipedia.org\]](#)
- [3. Armethion announces issuance of a new U.S. patent for its Phase 2 clinical stage novel oral anti-arrhythmic budiodarone \[innovationsincrm.com\]](#)
- [4. medchemexpress.com \[medchemexpress.com\]](#)
- To cite this document: BenchChem. [Validating the Antiarrhythmic Effects of Budiodarone In Vivo: A Comparative Guide]. BenchChem, [2026]. [Online PDF]. Available at: [\[https://www.benchchem.com/product/b1668027/docs#validating-the-antiarrhythmic-effects-of-budiodarone-in-vivo-a-comparative-guide\]](https://www.benchchem.com/product/b1668027/docs#validating-the-antiarrhythmic-effects-of-budiodarone-in-vivo-a-comparative-guide)

Disclaimer & Data Validity:

The information provided in this document is for Research Use Only (RUO) and is strictly not intended for diagnostic or therapeutic procedures. While BenchChem strives to provide accurate protocols, we make no warranties, express or implied, regarding the fitness of this product for every specific experimental setup.

Technical Support: The protocols provided are for reference purposes. Unsure if this reagent suits your experiment?

Need Industrial/Bulk Grade? [Request Custom Synthesis Quote](#)

BenchChem

Our mission is to be the trusted global source of essential and advanced chemicals, empowering scientists and researchers to drive progress in science and industry.

Contact

Address: 3281 E Guasti Rd
Ontario, CA 91761, United States
Phone: (601) 213-4426
Email: info@benchchem.com

[Contact our Ph.D. Support Team for a compatibility check](#)