

Technical Support Center: Optimizing CBK289001 Concentration for Experiments

Author: BenchChem Technical Support Team. **Date:** April 2026

Compound of Interest

Compound Name: CBK289001

Cat. No.: B1668688

[Get Quote](#)

This technical support center provides researchers, scientists, and drug development professionals with comprehensive guidance on utilizing **CBK289001**, a potent inhibitor of Tartrate-Resistant Acid Phosphatase (TRAP/ACP5), in their experiments. This guide includes frequently asked questions, troubleshooting advice, detailed experimental protocols, and visual representations of key biological pathways and workflows to ensure the successful application of **CBK289001**.

Frequently Asked Questions (FAQs)

Q1: What is the mechanism of action of **CBK289001**?

CBK289001 is a small molecule inhibitor of Tartrate-Resistant Acid Phosphatase (TRAP), also known as Acid Phosphatase 5 (ACP5). TRAP is a metalloenzyme involved in various physiological and pathological processes, including bone resorption and cancer metastasis. By inhibiting TRAP, **CBK289001** can modulate downstream signaling pathways, such as those involving Transforming Growth Factor- β (TGF- β) and CD44, which are critical in cell migration and invasion.

Q2: What are the recommended starting concentrations for in vitro experiments?

The optimal concentration of **CBK289001** depends on the specific cell line and assay. Based on available data, concentrations between 20 μ M and 100 μ M have been shown to significantly inhibit cell migration in TRAP-overexpressing MDA-MB-231 breast cancer cells.[1] For initial experiments, a dose-response study is recommended to determine the EC50 for your specific cellular system.

Q3: How should I prepare and store **CBK289001**?

For in vitro use, **CBK289001** can be dissolved in DMSO to prepare a high-concentration stock solution (e.g., 10 mM). It is crucial to use freshly opened, anhydrous DMSO to ensure maximum solubility. Stock solutions should be stored in small aliquots at -20°C for short-term storage (up to 1 month) or -80°C for long-term storage (up to 6 months) to prevent degradation from repeated freeze-thaw cycles. If precipitation is observed upon thawing, gentle warming and/or sonication can be used to redissolve the compound.

Q4: Is **CBK289001** suitable for in vivo studies?

Yes, formulations for **CBK289001** are available for in vivo experiments. Common solvent systems include a mixture of 10% DMSO, 40% PEG300, 5% Tween-80, and 45% saline, or a formulation with 10% DMSO and 90% corn oil. These formulations have been shown to achieve a clear solution with a solubility of at least 2.5 mg/mL.

Troubleshooting Guide

Issue	Possible Cause(s)	Suggested Solution(s)
<p>Low or no inhibition of cell migration</p>	<p>- Suboptimal concentration of CBK289001.- Low expression of TRAP/ACP5 in the cell line.- Insufficient incubation time.</p>	<p>- Perform a dose-response experiment to determine the optimal concentration.- Confirm TRAP/ACP5 expression in your cell line via Western Blot or qPCR.- Optimize the incubation time; significant inhibition has been observed after 24 hours of treatment.[1]</p>
<p>High cell toxicity or unexpected phenotype</p>	<p>- Off-target effects of CBK289001.- High concentration of DMSO in the final culture medium.</p>	<p>- Use the lowest effective concentration of CBK289001.- Include appropriate controls, such as a structurally unrelated TRAP/ACP5 inhibitor or siRNA-mediated knockdown of ACP5 to confirm the phenotype is on-target.- Ensure the final DMSO concentration in your assay does not exceed 0.5%.</p>
<p>Precipitation of CBK289001 in culture medium</p>	<p>- Poor solubility of the compound in aqueous solutions.- Interaction with components of the cell culture medium.</p>	<p>- Prepare fresh dilutions of CBK289001 from a high-concentration DMSO stock for each experiment.- If precipitation persists, consider using a different formulation or adding a small amount of a biocompatible surfactant, ensuring it does not affect your experimental outcome.</p>
<p>Inconsistent results between experiments</p>	<p>- Variability in cell passage number or health.- Inconsistent</p>	<p>- Use cells within a consistent and low passage number range.- Prepare a large batch</p>

preparation of CBK289001 solutions.- Pipetting errors.

of CBK289001 stock solution for a series of experiments.- Use calibrated pipettes and ensure thorough mixing of solutions.

Data Summary

In Vitro Efficacy of CBK289001

Parameter	Value	Assay Conditions	Reference
IC50 (TRAP 5bMV)	125 μ M	Biochemical Assay	[1]
IC50 (TRAP 5bOX)	4.21 μ M	Biochemical Assay	[1]
IC50 (TRAP 5aOX)	14.2 μ M	Biochemical Assay	[1]
Effective Concentration	20 μ M - 100 μ M	Inhibition of TRAP3high cell migration	

Key Experimental Protocols

Protocol 1: MDA-MB-231 Cell Culture

This protocol outlines the standard procedure for culturing MDA-MB-231 human breast cancer cells, which are commonly used in migration and invasion assays with **CBK289001**.

Materials:

- MDA-MB-231 cells
- DMEM High Glucose medium
- Fetal Bovine Serum (FBS)
- Penicillin-Streptomycin (Pen-Strep)
- 0.25% Trypsin-EDTA

- Phosphate-Buffered Saline (PBS)

Procedure:

- Culture MDA-MB-231 cells in DMEM High Glucose medium supplemented with 10% FBS and 1% Pen-Strep.
- Maintain the cells in a humidified incubator at 37°C with 5% CO₂.
- For subculturing, wash the cells with PBS and detach them using 0.25% Trypsin-EDTA when they reach 80-90% confluency.
- Neutralize the trypsin with complete medium, centrifuge the cells, and resuspend them in fresh medium for plating.

Protocol 2: Transwell Cell Migration Assay

This protocol describes a common method to assess the effect of **CBK289001** on the migratory capacity of cancer cells.

Materials:

- MDA-MB-231 cells
- Transwell inserts (8 µm pore size)
- Serum-free DMEM
- Complete DMEM (with 10% FBS)
- **CBK289001**
- Crystal Violet stain
- Cotton swabs

Procedure:

- Seed MDA-MB-231 cells (e.g., 5×10^4 cells) in the upper chamber of the Transwell insert in serum-free medium containing the desired concentration of **CBK289001** or vehicle control (DMSO).
- Add complete medium (containing 10% FBS as a chemoattractant) to the lower chamber.
- Incubate the plate for 24 hours at 37°C in a 5% CO₂ incubator.
- After incubation, remove the non-migrated cells from the upper surface of the insert with a cotton swab.
- Fix the migrated cells on the lower surface of the membrane with methanol and stain with Crystal Violet.
- Count the number of migrated cells in several fields of view under a microscope.

Visualizations

Signaling Pathways

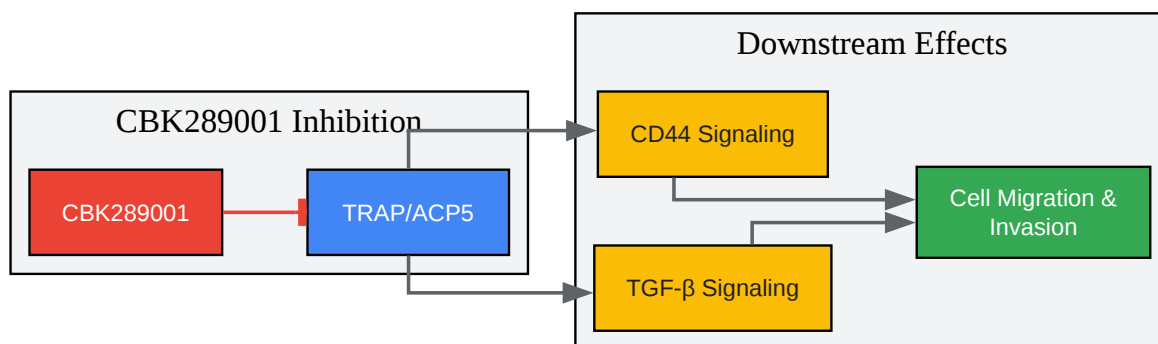

[Click to download full resolution via product page](#)

Caption: **CBK289001** inhibits TRAP/ACP5, modulating downstream TGF- β and CD44 signaling to reduce cell migration.

Experimental Workflow

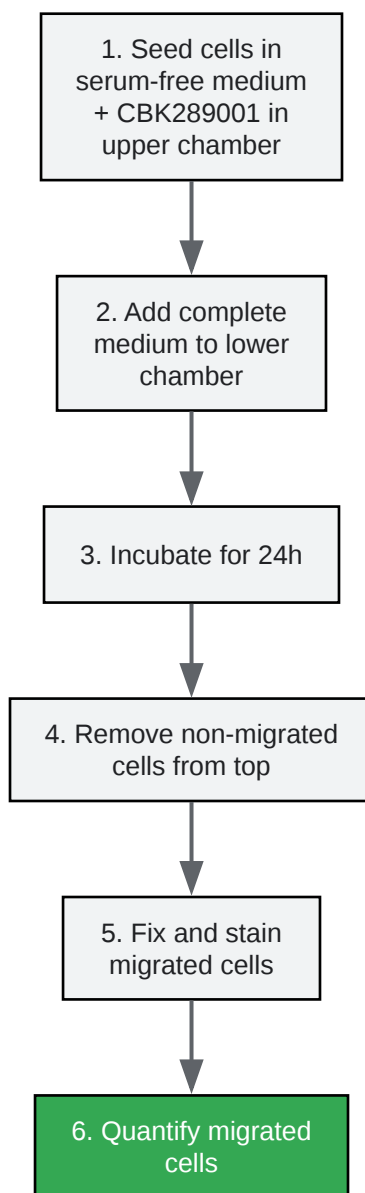

[Click to download full resolution via product page](#)

Caption: Workflow for a Transwell cell migration assay to evaluate the effect of **CBK289001**.

Troubleshooting Logic

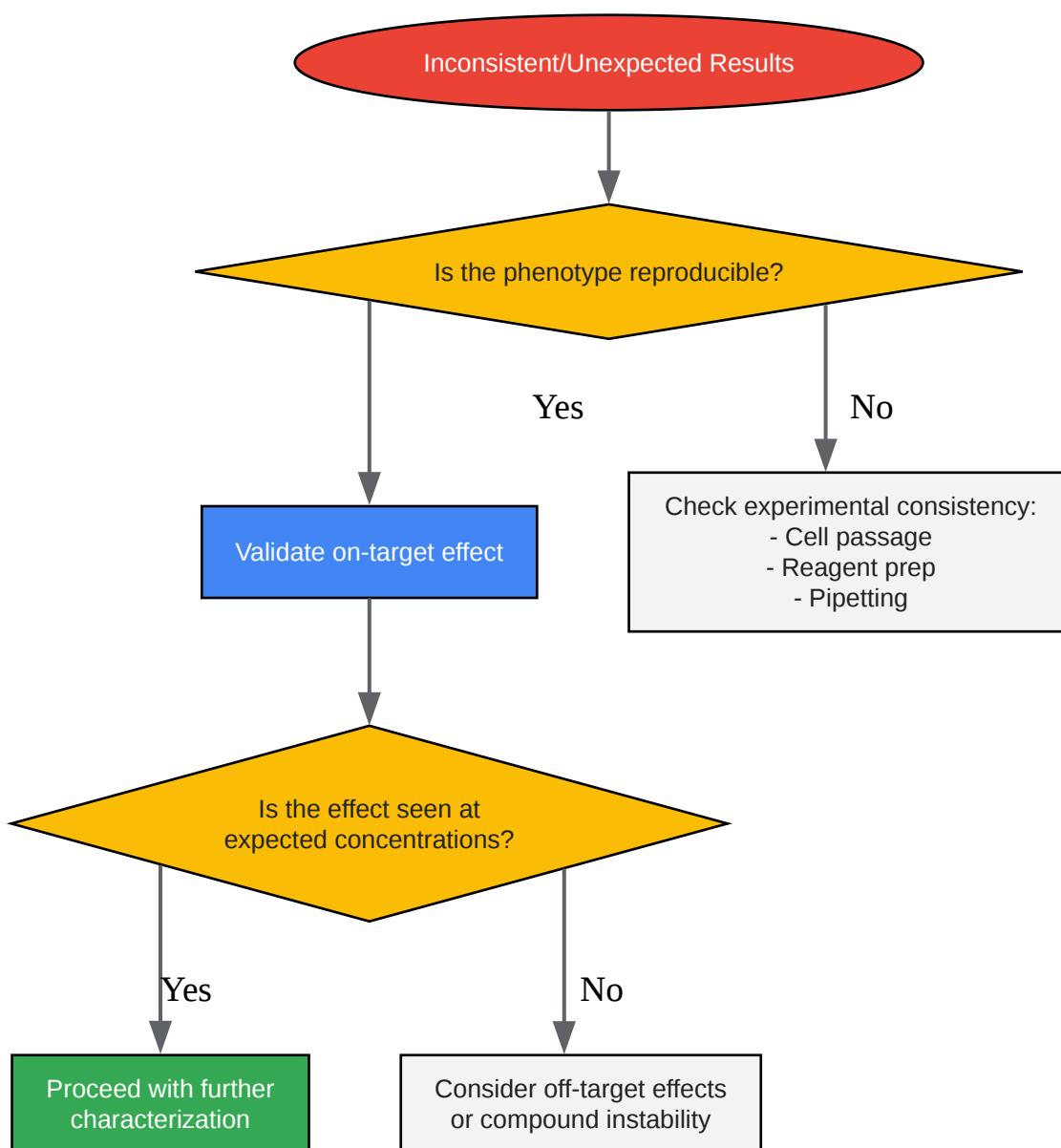

[Click to download full resolution via product page](#)

Caption: A logical flowchart for troubleshooting unexpected results in **CBK289001** experiments.

Need Custom Synthesis?

BenchChem offers custom synthesis for rare earth carbides and specific isotopic labeling.

Email: info@benchchem.com or [Request Quote Online](#).

References

- [1. Transforming growth factor- \$\beta\$ signaling in cancer invasion and metastasis | Semantic Scholar \[semanticscholar.org\]](#)
- To cite this document: BenchChem. [Technical Support Center: Optimizing CBK289001 Concentration for Experiments]. BenchChem, [2026]. [Online PDF]. Available at: [<https://www.benchchem.com/product/b1668688/docs#technical-support-center-optimizing-cbk289001-concentration-for-experiments>]

Disclaimer & Data Validity:

The information provided in this document is for Research Use Only (RUO) and is strictly not intended for diagnostic or therapeutic procedures. While BenchChem strives to provide accurate protocols, we make no warranties, express or implied, regarding the fitness of this product for every specific experimental setup.

Technical Support: The protocols provided are for reference purposes. Unsure if this reagent suits your experiment?

Need Industrial/Bulk Grade? [Request Custom Synthesis Quote](#)

BenchChem

Our mission is to be the trusted global source of essential and advanced chemicals, empowering scientists and researchers to drive progress in science and industry.

Contact

Address: 3281 E Guasti Rd
Ontario, CA 91761, United States
Phone: (601) 213-4426
Email: info@benchchem.com

[Contact our Ph.D. Support Team for a compatibility check](#)