

Technical Support Center: Challenges in Long-Term Administration of Amiodarone

Author: BenchChem Technical Support Team. **Date:** April 2026

Compound of Interest

Compound Name: *Budiodarone*

CAS No.: *335148-45-3*

Cat. No.: *B1668027*

[Get Quote](#)

Disclaimer: The term "**Budiodarone**" was not found in scientific literature. This guide has been developed based on the assumption that the query pertains to Amiodarone, a potent antiarrhythmic agent with well-documented challenges in long-term administration.

This technical support center provides researchers, scientists, and drug development professionals with comprehensive troubleshooting guides and frequently asked questions (FAQs) to address specific issues encountered during experiments involving the long-term administration of Amiodarone.

Frequently Asked Questions (FAQs)

Q1: What is the primary mechanism of action for Amiodarone?

A1: Amiodarone is a class III antiarrhythmic agent.^[1] Its primary mechanism involves blocking potassium channels, which prolongs the repolarization phase (phase 3) of the cardiac action potential.^{[1][2][3]} This action increases the effective refractory period in cardiac tissues, reducing myocardial cell excitability.^[1] Amiodarone also exhibits effects similar to other

antiarrhythmic classes by blocking sodium and calcium channels and possessing non-competitive β -adrenergic inhibitory properties.[1][2][3]

Q2: Why is long-term administration of Amiodarone challenging?

A2: Long-term amiodarone use is associated with a risk of significant adverse effects due to its chemical properties and pharmacokinetics.[4] The drug is lipophilic, leading to a large volume of distribution and accumulation in various tissues, including the lungs, liver, thyroid, and skin.[3][5] It also has a very long elimination half-life, ranging from several weeks to months, meaning that adverse effects can appear late and persist long after discontinuation of the drug.[4][6]

Q3: What are the most common organ toxicities observed with chronic Amiodarone administration?

A3: The most common and clinically significant organ toxicities associated with long-term amiodarone therapy include:

- Pulmonary toxicity: This is a serious complication that can manifest as interstitial pneumonitis or fibrosis.[6][7]
- Thyroid dysfunction: Due to its high iodine content and structural similarity to thyroxine, amiodarone can induce both hypothyroidism and hyperthyroidism (amiodarone-induced thyrotoxicosis).[6][8][9]
- Hepatotoxicity: Liver injury can range from asymptomatic elevation of liver enzymes to severe hepatitis and cirrhosis.[6][9][10]
- Ocular abnormalities: Corneal microdeposits are very common, though usually benign. Optic neuropathy is a rare but serious adverse effect.[6][8]
- Dermatological effects: Photosensitivity and a blue-gray skin discoloration are potential side effects of long-term use.[8][11]
- Neurological toxicity: Peripheral neuropathy can occur with prolonged administration.[11]
- Cardiovascular effects: Bradycardia and conduction disturbances can occur.[8]

Q4: How does Amiodarone interact with other common laboratory agents or drugs?

A4: Amiodarone inhibits several cytochrome P450 enzymes (including CYP3A4, CYP2C9, and CYP2D6), leading to significant drug-drug interactions.[12][13] This can increase the plasma concentrations and potential toxicity of co-administered drugs such as warfarin, digoxin, statins, and certain antiarrhythmics.[13][14][15][16] It is crucial to review all co-administered agents in experimental models to avoid confounding results. Grapefruit juice can also increase amiodarone levels and should be avoided.[11][16]

Troubleshooting Guides for Experimental Issues

Q5: We are observing unexpected variability in cardiac electrophysiology measurements in our animal models on long-term Amiodarone. What could be the cause?

A5: Variability in electrophysiological outcomes can stem from several factors:

- Inconsistent drug accumulation: Amiodarone has a long and variable half-life, and steady-state concentrations can take a long time to achieve.[1] Ensure your dosing regimen is sufficient to reach a stable tissue concentration.
- Metabolic interactions: Check for other compounds administered to the animals that might interact with Amiodarone's metabolism.[13]
- Thyroid function: Amiodarone-induced thyroid dysfunction can independently alter cardiac electrophysiology.[8] It is advisable to monitor thyroid hormone levels (TSH, free T4) in your animal models.[5]

Q6: Our experimental subjects are showing signs of respiratory distress after several weeks of Amiodarone administration. How can we investigate if this is Amiodarone-induced pulmonary toxicity (APT)?

A6: To investigate potential APT, a multi-faceted approach is recommended:

- Discontinuation: The primary step in managing suspected APT is the immediate discontinuation of Amiodarone.[17]

- **Imaging:** In clinical settings, chest X-rays or high-resolution computed tomography (CT) are used to identify characteristic changes like interstitial infiltrates or ground-glass opacities.[17][18] Similar imaging modalities can be used in animal models.
- **Histopathology:** Lung tissue analysis for the presence of foamy macrophages (lipid-laden macrophages), inflammation, and fibrosis is a key diagnostic feature.[17][19]
- **Exclusion of other causes:** Rule out infections or other potential causes of respiratory distress in your experimental setting.[17]

Q7: We have noted significant elevations in liver enzymes (ALT/AST) in our experimental cohort. How can we confirm this is due to Amiodarone and manage it in our study?

A7: Amiodarone-induced hepatotoxicity is a known complication.[10]

- **Confirmation:** The elevation of liver transaminases is a common sign.[9] A liver biopsy showing steatosis, inflammation, and fibrosis can confirm the diagnosis.[10] In some cases, CT scans may reveal a high-density liver due to iodine accumulation.[20]
- **Management:** If liver enzyme levels are more than three times the normal limit, discontinuation of the drug should be considered unless the experimental endpoint is critically dependent on continued administration.[9]
- **Hyperacute Toxicity (IV studies):** If using an intravenous formulation, be aware that a rapid, severe hepatotoxicity can occur within 24 hours.[21][22] This may be related to the solvent (Polysorbate 80) rather than the drug itself.[21] Some studies suggest N-acetylcysteine (NAC) may be beneficial in treating this acute injury.[23]

Q8: Our study involves co-administration of Warfarin and Amiodarone, and we are seeing inconsistent anticoagulation effects. How should we proceed?

A8: This is a well-documented drug interaction. Amiodarone inhibits the metabolism of warfarin, leading to an increased anticoagulant effect and risk of bleeding.[15][16]

- **Dose Adjustment:** When Amiodarone is initiated, the dose of warfarin typically needs to be reduced by 20-50%.[13]

- **Close Monitoring:** Frequent monitoring of coagulation parameters (e.g., prothrombin time/INR) is essential to maintain the desired level of anticoagulation.
- **Delayed Interaction:** Be aware that the peak effect of this interaction can be delayed for up to seven weeks after starting co-administration due to Amiodarone's long half-life.[9][24]

Quantitative Data Summary

Table 1: Incidence of Key Adverse Effects with Long-Term Amiodarone Therapy

Adverse Effect	Approximate Incidence	Notes	Citations
Pulmonary Toxicity	Up to 17% (can be fatal in up to 10% of cases)	Risk increases with higher cumulative doses and duration of therapy.	[7]
Thyroid Dysfunction	15-20% of patients	Can manifest as either hypothyroidism (more common) or hyperthyroidism.	[2]
Elevated Liver Enzymes	15-50% (transient)	Clinically apparent liver disease occurs in ~1% annually.	[10]
Corneal Microdeposits	70-100% of patients	Generally asymptomatic and reversible upon discontinuation.	[8]
Bradycardia/Conduction Disturbance	~9.6%	More frequent in older patients or those with structural heart disease.	[8]
Drug Withdrawal due to Intolerance	10.7 per 100 patient-years	Significantly higher than placebo or rate control drugs.	[25]

Table 2: Pharmacokinetic Parameters of Amiodarone

Parameter	Value	Notes	Citations
Bioavailability (Oral)	20% - 80% (highly variable)	Absorption is increased with food.	[4]
Time to Peak Plasma Concentration	3 - 7 hours	Onset of action can be delayed (days to weeks).	[1]
Elimination Half-Life	Up to 100 days (highly variable)	Contributes to drug accumulation and prolonged side effects.	[26][27]
Metabolism	Primarily hepatic via CYP3A4 and CYP2C8	Active metabolite is desethylamiodarone (DEA).	[12]

Detailed Experimental Protocols

Protocol 1: Monitoring for Amiodarone-Induced Organ Toxicity in a Rodent Model

- **Baseline Measurements:** Before initiating Amiodarone administration, collect baseline data for all animals. This should include:
 - Blood samples for baseline liver function tests (ALT, AST), thyroid function tests (TSH, T4), and renal function (Urea, Creatinine).[5][28]
 - Baseline electrocardiogram (ECG) to assess heart rate and QT interval.[5]
- **Amiodarone Administration:** Administer Amiodarone orally at the desired dose. The vehicle and route should be consistent throughout the experiment.
- **Regular Monitoring (e.g., every 6 months equivalent):**
 - Perform repeat blood tests for liver and thyroid function.[5][9] A low threshold for suspecting toxicity is advised.[29]

- Record ECGs to monitor for bradycardia and QT prolongation.[5]
- Conduct regular clinical examinations, noting any signs of respiratory distress, weight loss, or neurological changes.[6]
- Terminal Endpoint Analysis:
 - At the end of the study period, perform a comprehensive analysis.
 - Histopathology: Collect tissue samples from the lungs, liver, and thyroid for histological examination. Look for key pathological changes such as pulmonary fibrosis, hepatic steatosis, and thyroid follicular cell damage.[10][17]
 - Ocular Examination: If feasible, perform ophthalmologic exams to check for corneal deposits.[5]

Protocol 2: Investigating Amiodarone-Induced Thyrotoxicosis (AIT)

- Induction of AIT: Administer a chronic regimen of Amiodarone to experimental animals.
- Diagnosis:
 - Monitor serum TSH and free thyroid hormone levels. Suppressed TSH with elevated free T4/T3 indicates thyrotoxicosis.[30]
 - Utilize imaging such as color-flow Doppler sonography of the thyroid. Increased vascularity suggests Type 1 AIT (iodine-induced hyperthyroidism), while absent hypervascularity suggests Type 2 AIT (destructive thyroiditis).[30][31]
- Experimental Treatment Arms:
 - Type 1 AIT Model: Treat with a thionamide (e.g., methimazole) to block new hormone synthesis.[30][32]
 - Type 2 AIT Model: Treat with glucocorticoids (e.g., prednisone) for their anti-inflammatory effects.[30][32]
- Outcome Assessment:

- Measure the time to normalization of thyroid hormone levels in each treatment group.
- Assess changes in cardiac function (e.g., heart rate, arrhythmia burden) in response to treatment.

Visualized Signaling Pathways and Workflows

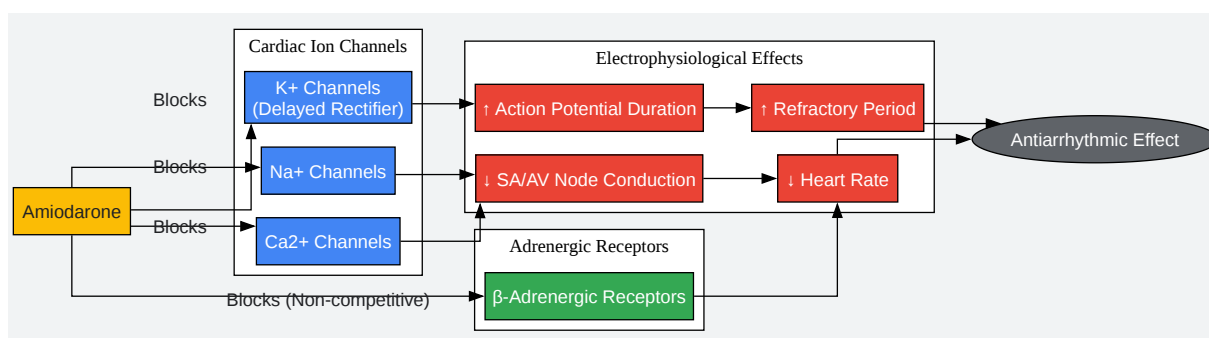

[Click to download full resolution via product page](#)

Caption: Amiodarone's multi-channel blocking effects on cardiac cells.

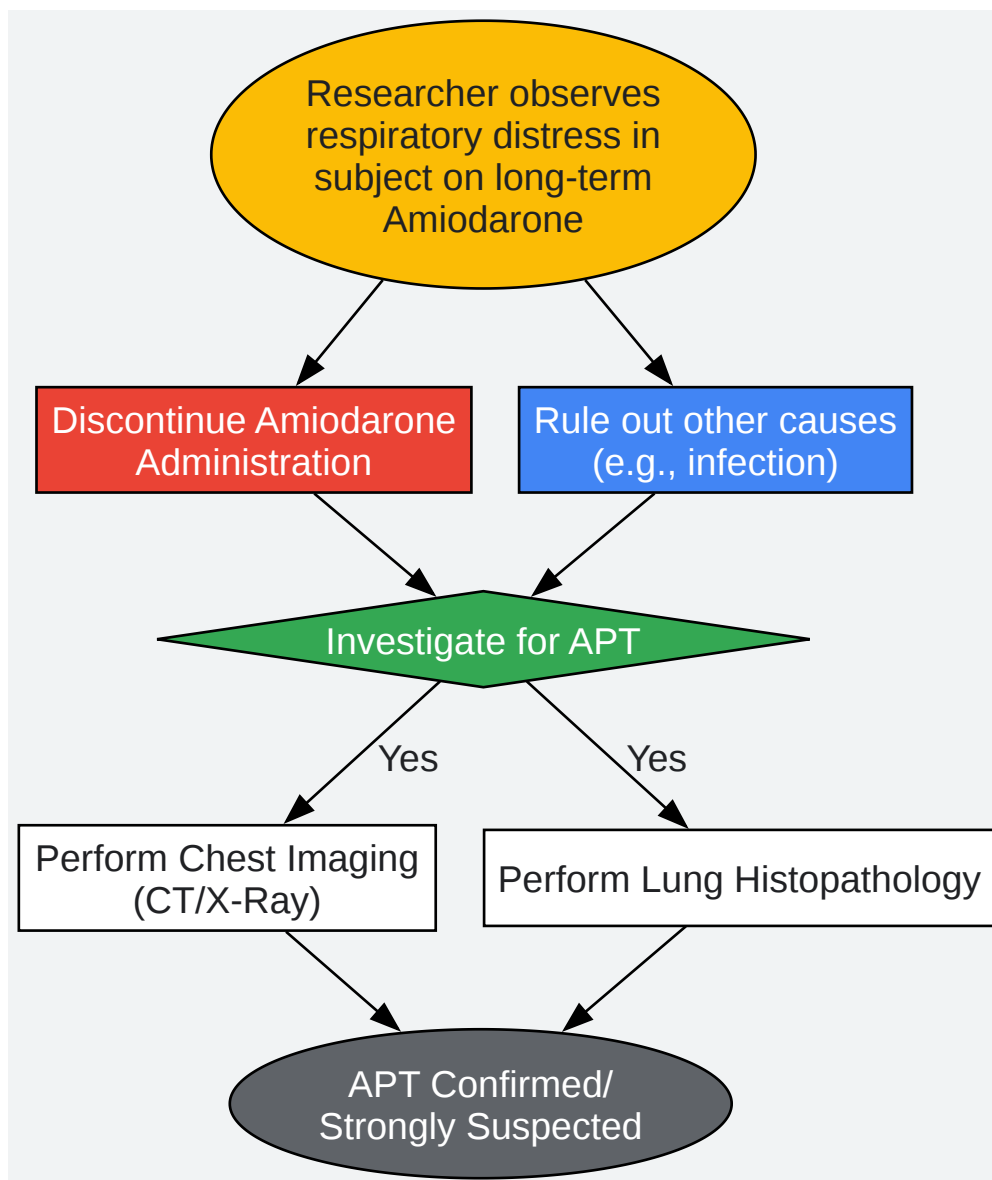

[Click to download full resolution via product page](#)

Caption: Workflow for troubleshooting suspected Amiodarone Pulmonary Toxicity.

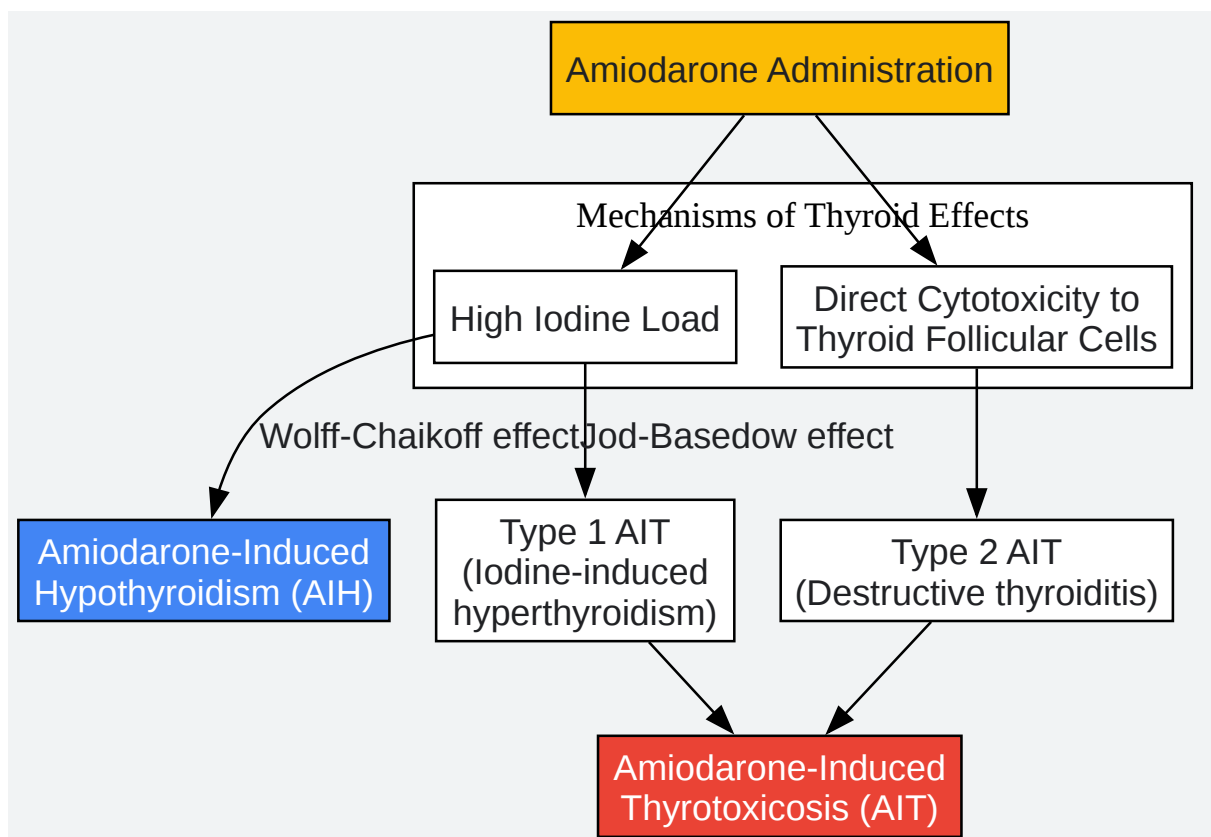

[Click to download full resolution via product page](#)

Caption: Pathophysiological pathways of Amiodarone-induced thyroid dysfunction.

Need Custom Synthesis?

BenchChem offers custom synthesis for rare earth carbides and specific isotopic labeling.

Email: info@benchchem.com or [Request Quote Online](#).

References

- 1. go.drugbank.com [go.drugbank.com]
- 2. Amiodarone - Wikipedia [en.wikipedia.org]
- 3. What is the mechanism of Amiodarone Hydrochloride? [synapse.patsnap.com]
- 4. Amiodarone Therapy: Updated Practical Insights - PMC [pmc.ncbi.nlm.nih.gov]
- 5. droracle.ai [droracle.ai]

- [6. droracle.ai \[droracle.ai\]](#)
- [7. Amiodarone side effects and how to avoid them | SingleCare \[singlecare.com\]](#)
- [8. Adverse effects of long-term amiodarone therapy - PMC \[pmc.ncbi.nlm.nih.gov\]](#)
- [9. Amiodarone: Guidelines for Use and Monitoring | AAFP \[aafp.org\]](#)
- [10. Amiodarone - LiverTox - NCBI Bookshelf \[ncbi.nlm.nih.gov\]](#)
- [11. Amiodarone \(oral route\) - Side effects & dosage - Mayo Clinic \[mayoclinic.org\]](#)
- [12. Amiodarone | C25H29I2NO3 | CID 2157 - PubChem \[pubchem.ncbi.nlm.nih.gov\]](#)
- [13. Pharmacokinetic drug interactions with amiodarone - PubMed \[pubmed.ncbi.nlm.nih.gov\]](#)
- [14. Amiodarone - Mechanism, Indication, Contraindications, Dosing, Adverse Effect, Interaction, Hepatic Dose | Drug Index | Pediatric Oncall \[pediatriconcall.com\]](#)
- [15. Amiodarone Interactions: What to Avoid With Amiodarone - GoodRx \[goodrx.com\]](#)
- [16. Amiodarone: Arrhythmia Drug Side Effects & Interactions \[medicinenet.com\]](#)
- [17. Severe amiodarone induced pulmonary toxicity - Nacca - Journal of Thoracic Disease \[jtd.amegroups.org\]](#)
- [18. wikem.org \[wikem.org\]](#)
- [19. dynamed.com \[dynamed.com\]](#)
- [20. Amiodarone-induced hepatotoxicity | BMJ Case Reports \[casereports.bmj.com\]](#)
- [21. Episode 142: Amiodarone induced hepatotoxicity - Pharmacy Joe - \[pharmacyjoe.com\]](#)
- [22. karger.com \[karger.com\]](#)
- [23. Successful treatment of amiodarone-induced hepatic injury with n-acetylcysteine: A case report - PMC \[pmc.ncbi.nlm.nih.gov\]](#)
- [24. Amiodarone: guidelines for use and monitoring - PubMed \[pubmed.ncbi.nlm.nih.gov\]](#)
- [25. Benefits and Risks of Long-term Amiodarone Therapy for Persistent Atrial Fibrillation: A Meta-analysis - PMC \[pmc.ncbi.nlm.nih.gov\]](#)
- [26. ahajournals.org \[ahajournals.org\]](#)
- [27. derangedphysiology.com \[derangedphysiology.com\]](#)
- [28. droracle.ai \[droracle.ai\]](#)
- [29. derbyshiremedicinesmanagement.nhs.uk \[derbyshiremedicinesmanagement.nhs.uk\]](#)
- [30. academic.oup.com \[academic.oup.com\]](#)
- [31. ccjm.org \[ccjm.org\]](#)

- [32. Amiodarone-induced thyrotoxicosis: A review - PMC \[pmc.ncbi.nlm.nih.gov\]](#)
- To cite this document: BenchChem. [Technical Support Center: Challenges in Long-Term Administration of Amiodarone]. BenchChem, [2026]. [Online PDF]. Available at: [<https://www.benchchem.com/product/b1668027/docs#technical-support-center-challenges-in-long-term-administration-of-amiodarone>]

Disclaimer & Data Validity:

The information provided in this document is for Research Use Only (RUO) and is strictly not intended for diagnostic or therapeutic procedures. While BenchChem strives to provide accurate protocols, we make no warranties, express or implied, regarding the fitness of this product for every specific experimental setup.

Technical Support: The protocols provided are for reference purposes. Unsure if this reagent suits your experiment?

Need Industrial/Bulk Grade? [Request Custom Synthesis Quote](#)

BenchChem

Our mission is to be the trusted global source of essential and advanced chemicals, empowering scientists and researchers to drive progress in science and industry.

Contact

Address: 3281 E Guasti Rd
Ontario, CA 91761, United States
Phone: (601) 213-4426
Email: info@benchchem.com

[Contact our Ph.D. Support Team for a compatibility check](#)