

Potential for receptor desensitization with chronic CGP 36742 use.

Author: BenchChem Technical Support Team. **Date:** April 2026

Compound of Interest

Compound Name:	CGP 36742
CAS No.:	123690-78-8
Cat. No.:	B1668497

[Get Quote](#)

Technical Support Center: CGP 36742

This technical support center provides troubleshooting guides and frequently asked questions (FAQs) for researchers, scientists, and drug development professionals working with the GABA-B receptor antagonist, **CGP 36742**.

Frequently Asked Questions (FAQs)

Q1: We are planning a long-term in vivo study using **CGP 36742**. Should we be concerned about receptor desensitization (tachyphylaxis) with chronic use?

A: Based on available preclinical data, chronic administration of **CGP 36742** does not appear to cause GABA-B receptor desensitization. In fact, studies suggest the opposite: a potential for receptor upregulation or sensitization. Chronic treatment with **CGP 36742** has been shown to increase the functional responses to GABA-B receptor activation.^[1] For instance, one study reported that pre-treatment with **CGP 36742** led to a significant increase in (-)-baclofen-mediated post-synaptic responses in olfactory cortical neurons.^[1] Another study found that

chronic administration of SGS742 (an alternative name for **CGP 36742**) resulted in an upregulation of GABA-B receptors in the frontal cortex of rats.[2]

Q2: What is the proposed mechanism for the observed increase in GABA-B receptor sensitivity following chronic **CGP 36742** treatment?

A: The likely mechanism is a compensatory homeostatic response to the prolonged blockade of GABA-B receptors. By persistently inhibiting the receptor's natural activation by GABA, the cell may respond by increasing the number of receptors on the cell surface or enhancing the efficiency of the downstream signaling cascade to maintain physiological balance. This is a common phenomenon observed with antagonist drugs for many G-protein coupled receptors (GPCRs).

Q3: Are there any conflicting reports or is this upregulation consistently observed?

A: The available literature consistently points towards an upregulation or sensitization of GABA-B receptors with chronic antagonist treatment. A study demonstrated that while a GABA-B agonist, (-)-baclofen, led to desensitization, the antagonist **CGP 36742** produced an opposing effect of sensitization.[1] This suggests a robust regulatory mechanism within the GABA-B receptor system.

Q4: How might this potential for receptor upregulation impact our experimental design?

A: This is a critical consideration. If your study involves intermittent or washout periods, you may observe exaggerated responses to any endogenous GABA or exogenous GABA-B agonists administered after the chronic **CGP 36742** treatment has ceased. It is advisable to:

- Incorporate a washout period: Carefully consider the duration of the washout period to allow for receptor levels to return to baseline, if that is a desired endpoint.
- Include agonist challenge studies: To functionally assess the extent of receptor upregulation, consider including experimental groups that are challenged with a GABA-B agonist (like baclofen) at various time points.
- Measure receptor expression: If feasible, direct measurement of GABA-B receptor protein levels or mRNA in your tissue of interest can provide a quantitative assessment of upregulation.

Troubleshooting Guides

Problem: Inconsistent or exaggerated responses to GABA-B agonists after a period of **CGP 36742** administration.

- Possible Cause: This is likely due to the upregulation of GABA-B receptors as a compensatory response to chronic antagonism.
- Troubleshooting Steps:
 - Review Dosing and Treatment Schedule: Confirm the dose and duration of **CGP 36742** administration. Longer treatment periods are more likely to induce receptor upregulation.
 - Implement a Washout Period: If the experimental design allows, introduce a washout period before administering any GABA-B agonists to allow receptor sensitivity to normalize. The duration of this period may need to be determined empirically.
 - Conduct a Dose-Response Curve: Perform a dose-response curve for your GABA-B agonist to determine if there is a leftward shift, indicating increased potency, which is characteristic of receptor sensitization.
 - Biochemical Analysis: Consider performing Western blotting or qPCR to quantify GABA-B receptor protein or mRNA levels in your experimental and control groups to directly measure upregulation.

Problem: Unexpected changes in neuronal excitability in our control group not treated with **CGP 36742**.

- Possible Cause: While **CGP 36742** is a selective GABA-B receptor antagonist, it is important to consider the broader context of neuronal circuitry. GABA-B receptors are involved in regulating the release of other neurotransmitters.[3]
- Troubleshooting Steps:
 - Examine Experimental Conditions: Ensure all other experimental conditions are tightly controlled.

- Consider Off-Target Effects (less likely): While **CGP 36742** is reported to be selective, at very high concentrations, the possibility of off-target effects, though minimal, should be considered. Confirm that your working concentration is within the established selective range (IC50 = 36 μ M).[4]
- Evaluate Interacting Systems: GABA-B receptor activity can be modulated by other receptor systems, such as NMDA receptors.[5][6][7] Unforeseen activation of these systems could indirectly influence GABAergic tone.

Data Presentation

Table 1: Effects of Chronic **CGP 36742** and Baclofen Treatment on GABA-B Receptor Function

Treatment Group	Agonist Challenge	Outcome Measure	Result	Reference
Chronic CGP 36742	(-)-Baclofen	Post-synaptic hyperpolarizing responses	Significant Increase	[1]
Chronic CGP 36742	Synaptically-evoked late IPSPs	Amplitude	Significant Increase	[1]
Chronic (-)-Baclofen	(-)-Baclofen	Post-synaptic hyperpolarizing responses	Prevented/Abolished	[1]
Chronic (-)-Baclofen	Synaptically-evoked late IPSPs	Amplitude	Prevented/Abolished	[1]

Experimental Protocols

Key Experiment: Assessing Functional GABA-B Receptor Sensitivity Following Chronic Drug Treatment

This protocol is a generalized summary based on the methodology described in the referenced literature[1].

- Animal Model and Drug Administration:
 - Species: Wistar rats.
 - Treatment: Daily intraperitoneal (i.p.) injections of either vehicle, (-)-baclofen (10 mg/kg), or **CGP 36742** for 21 consecutive days.
- Brain Slice Preparation:
 - Following the 21-day treatment period, animals are euthanized.
 - The brain is rapidly removed and placed in ice-cold, oxygenated artificial cerebrospinal fluid (aCSF).
 - 450 μm thick brain slices containing the olfactory cortex are prepared using a vibratome.
 - Slices are allowed to recover in oxygenated aCSF at room temperature for at least 1 hour before recording.
- Intracellular Recording:
 - Slices are transferred to a recording chamber continuously perfused with oxygenated aCSF.
 - Intracellular recordings are obtained from neurons in the olfactory cortex using sharp microelectrodes filled with potassium acetate.
 - Stable resting membrane potential is established before any experimental manipulations.
- Functional Assays:
 - Agonist-induced Hyperpolarization: A range of concentrations of (-)-baclofen is applied to the bath to generate a cumulative concentration-response curve. The magnitude of the resulting membrane hyperpolarization is measured.

- Synaptically-Evoked Inhibitory Postsynaptic Potentials (IPSPs): A stimulating electrode is placed to evoke synaptic responses. The late, slow IPSP, which is mediated by GABA-B receptors, is isolated and its amplitude is measured before and after drug application.
- Data Analysis:
 - The amplitude of hyperpolarizing responses and IPSPs are compared between the different treatment groups (vehicle, chronic baclofen, chronic **CGP 36742**).
 - Statistical analysis (e.g., ANOVA) is used to determine the significance of any observed differences.

Visualizations

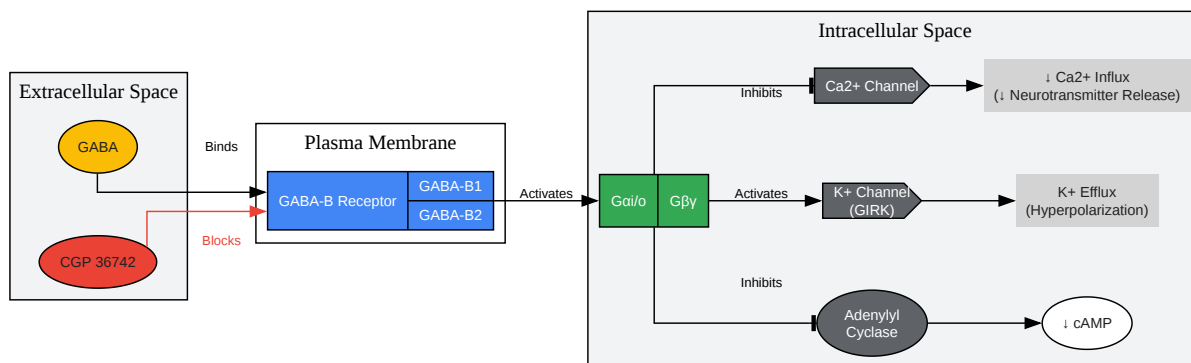

[Click to download full resolution via product page](#)

Caption: GABA-B receptor signaling pathway and the antagonistic action of **CGP 36742**.

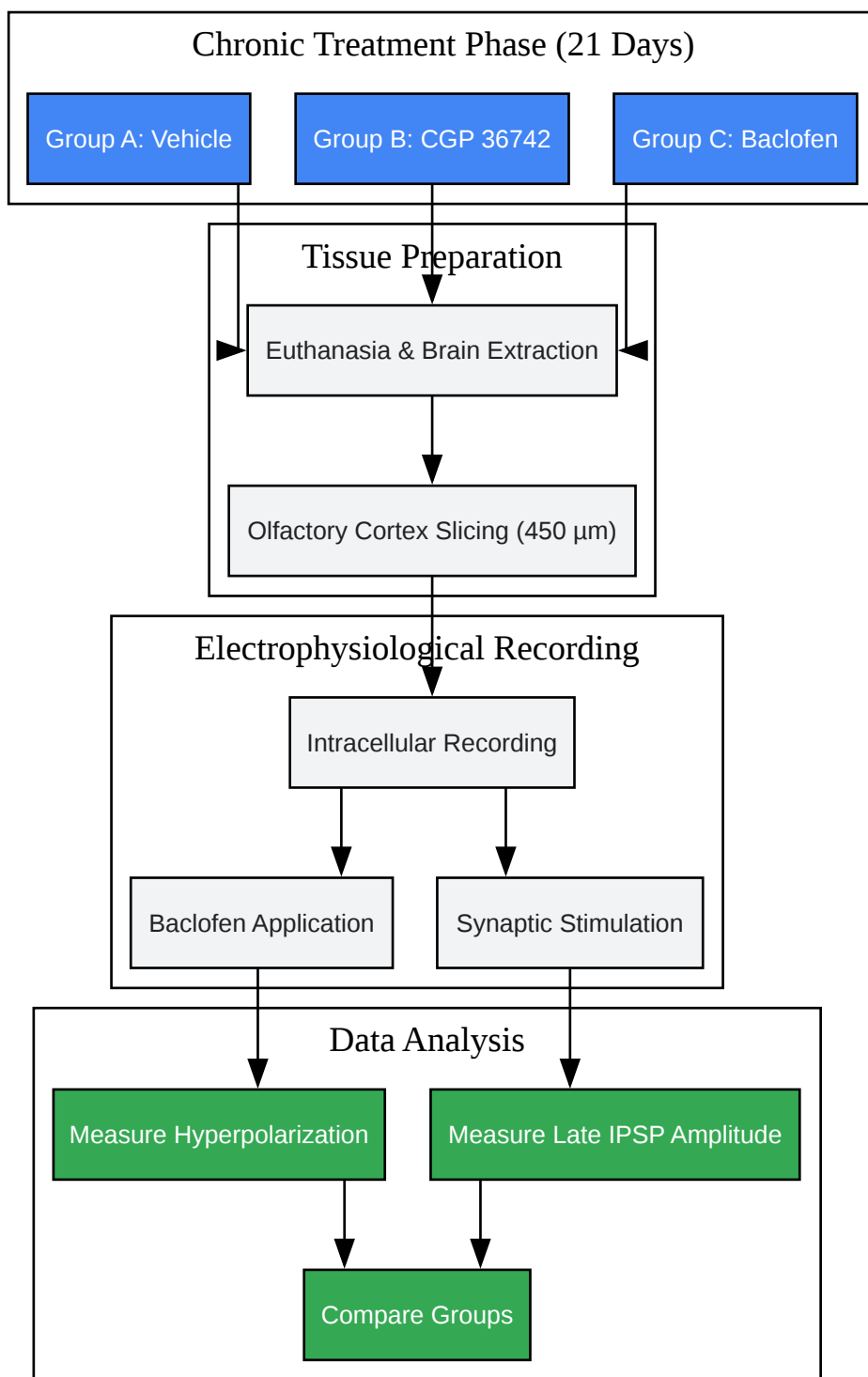

[Click to download full resolution via product page](#)

Caption: Experimental workflow for assessing GABA-B receptor sensitivity.

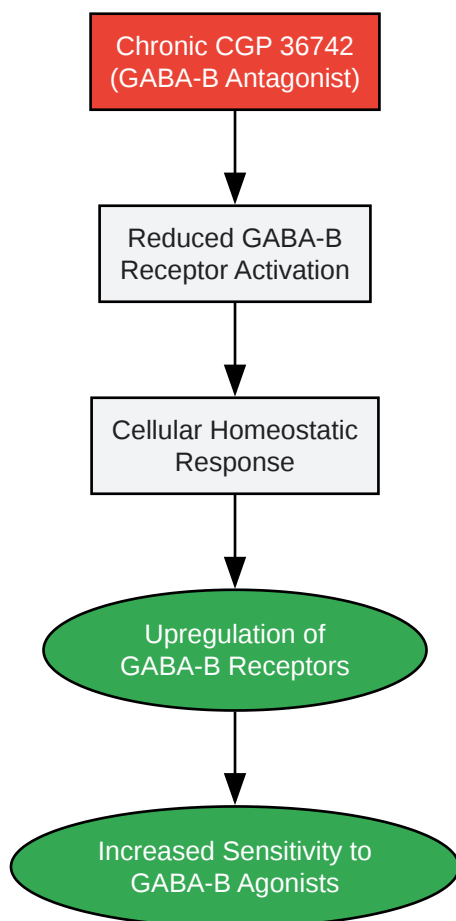

[Click to download full resolution via product page](#)

Caption: Logical flow of chronic antagonist use leading to receptor sensitization.

Need Custom Synthesis?

BenchChem offers custom synthesis for rare earth carbides and specific isotopic labeling.

Email: info@benchchem.com or [Request Quote Online](#).

References

- 1. Chronic (-)baclofen or CGP 36742 alters GABAB receptor sensitivity in rat brain and spinal cord - PubMed [pubmed.ncbi.nlm.nih.gov]
- 2. SGS742: the first GABA(B) receptor antagonist in clinical trials - PubMed [pubmed.ncbi.nlm.nih.gov]

- [3. What are GABAB receptor antagonists and how do they work? \[synapse.patsnap.com\]](#)
- [4. medchemexpress.com \[medchemexpress.com\]](#)
- [5. Differential Regulation of GABAB Receptor Trafficking by Different Modes of N-methyl-d-aspartate \(NMDA\) Receptor Signaling - PMC \[pmc.ncbi.nlm.nih.gov\]](#)
- [6. Diversity of structure and function of GABAB receptors: a complexity of GABAB-mediated signaling - PMC \[pmc.ncbi.nlm.nih.gov\]](#)
- [7. Differential regulation of GABAB receptor trafficking by different modes of N-methyl-D-aspartate \(NMDA\) receptor signaling - PubMed \[pubmed.ncbi.nlm.nih.gov\]](#)
- To cite this document: BenchChem. [Potential for receptor desensitization with chronic CGP 36742 use.]. BenchChem, [2026]. [Online PDF]. Available at: [\[https://www.benchchem.com/product/b1668497/docs#potential-for-receptor-desensitization-with-chronic-cgp-36742-use\]](https://www.benchchem.com/product/b1668497/docs#potential-for-receptor-desensitization-with-chronic-cgp-36742-use)

Disclaimer & Data Validity:

The information provided in this document is for Research Use Only (RUO) and is strictly not intended for diagnostic or therapeutic procedures. While BenchChem strives to provide accurate protocols, we make no warranties, express or implied, regarding the fitness of this product for every specific experimental setup.

Technical Support: The protocols provided are for reference purposes. Unsure if this reagent suits your experiment?

Need Industrial/Bulk Grade? [Request Custom Synthesis Quote](#)

BenchChem

Our mission is to be the trusted global source of essential and advanced chemicals, empowering scientists and researchers to drive progress in science and industry.

Contact

Address: 3281 E Guasti Rd
Ontario, CA 91761, United States
Phone: (601) 213-4426
Email: info@benchchem.com

Contact our Ph.D. Support Team for a compatibility check