

# Carazolol's Effects on the Central Nervous System: A Technical Guide

**Author:** BenchChem Technical Support Team. **Date:** December 2025

## Compound of Interest

Compound Name: Carazolol

Cat. No.: B1668300

[Get Quote](#)

For Researchers, Scientists, and Drug Development Professionals

## Abstract

**Carazolol** is a highly potent, non-selective  $\beta$ -adrenergic receptor antagonist and a  $\beta_3$ -adrenergic receptor agonist. Its lipophilic nature suggests the potential for central nervous system (CNS) penetration and subsequent neuropharmacological effects. This technical guide provides a comprehensive overview of the current understanding of **Carazolol**'s interactions with the CNS. It details its binding affinities to adrenergic receptors, explores potential downstream signaling pathways in neuronal cells, and outlines detailed experimental protocols for investigating its CNS effects. While direct preclinical and clinical studies on the specific CNS effects of **Carazolol** are limited, this guide synthesizes available data on **Carazolol**'s pharmacology and extrapolates potential CNS implications based on the known roles of  $\beta$ -adrenergic receptors in the brain and findings from studies on other  $\beta$ -blockers.

## Introduction

**Carazolol** is a carbazole derivative recognized for its high-affinity binding to  $\beta$ -adrenergic receptors.[1][2] Initially developed as a potent antihypertensive agent, its pharmacological profile as a non-selective  $\beta_1/\beta_2$  antagonist and a  $\beta_3$  agonist suggests a broader range of physiological effects.[3] Given its lipophilicity, **Carazolol** is predicted to cross the blood-brain barrier, making the investigation of its effects on the central nervous system a critical area of research.[4] Understanding these effects is crucial for identifying potential therapeutic

applications in neurological and psychiatric disorders, as well as for characterizing its neurotoxicological profile.

This guide summarizes the known quantitative data on **Carazolol**'s receptor interactions, delineates the putative signaling pathways it modulates within the CNS, and provides detailed experimental methodologies for its further investigation.

## Quantitative Data: Receptor Binding Affinities

The interaction of **Carazolol** with  $\beta$ -adrenergic receptors has been characterized in various in vitro studies. The following tables summarize the key binding affinity parameters.

Table 1: Binding Affinity of **Carazolol** for  $\beta$ 1 and  $\beta$ 2-Adrenergic Receptors

| Parameter | Receptor Subtype                   | Tissue/Cell Line                | Value                       | Reference |
|-----------|------------------------------------|---------------------------------|-----------------------------|-----------|
| Kd        | $\beta$ -receptors (non-selective) | Rat Cerebral Cortical Membranes | 0.15 nM                     | [4]       |
| Ki        | $\beta$ 1-receptors                | Calf Cerebral Cortex            | Equal affinity to $\beta$ 2 |           |
| Ki        | $\beta$ 2-receptors                | Calf Cerebellum                 | Equal affinity to $\beta$ 1 |           |

Table 2: Binding and Functional Activity of **Carazolol** at the  $\beta$ 3-Adrenergic Receptor

| Parameter          | Receptor Subtype              | Cell Line | Value               | Reference |
|--------------------|-------------------------------|-----------|---------------------|-----------|
| Ki                 | Human $\beta$ 3-adrenoceptor  | CHO cells | 2.0 $\pm$ 0.2 nM    |           |
| IC50               | Human $\beta$ 3-adrenoceptor  | CHO cells | 11.3 $\pm$ 1.2 nM   |           |
| EC50               | Murine $\beta$ 3-adrenoceptor | CHO cells | 25 nM               |           |
| Intrinsic Activity | Murine $\beta$ 3-adrenoceptor | CHO cells | 0.97 (Full Agonist) |           |

## Signaling Pathways in the Central Nervous System

**Carazolol**'s dual action as a  $\beta$ 1/ $\beta$ 2 antagonist and a  $\beta$ 3 agonist suggests complex modulatory effects on neuronal signaling. The following diagrams illustrate the putative signaling pathways affected by **Carazolol** in the CNS.

### Antagonism of $\beta$ 1/ $\beta$ 2-Adrenergic Receptor Signaling

In the CNS,  $\beta$ 1 and  $\beta$ 2-adrenergic receptors are coupled to the stimulatory G protein (Gs), which activates adenylyl cyclase (AC) to produce cyclic AMP (cAMP). cAMP, in turn, activates Protein Kinase A (PKA), leading to the phosphorylation of various downstream targets, including the transcription factor CREB (cAMP response element-binding protein). By blocking these receptors, **Carazolol** is expected to inhibit this signaling cascade.

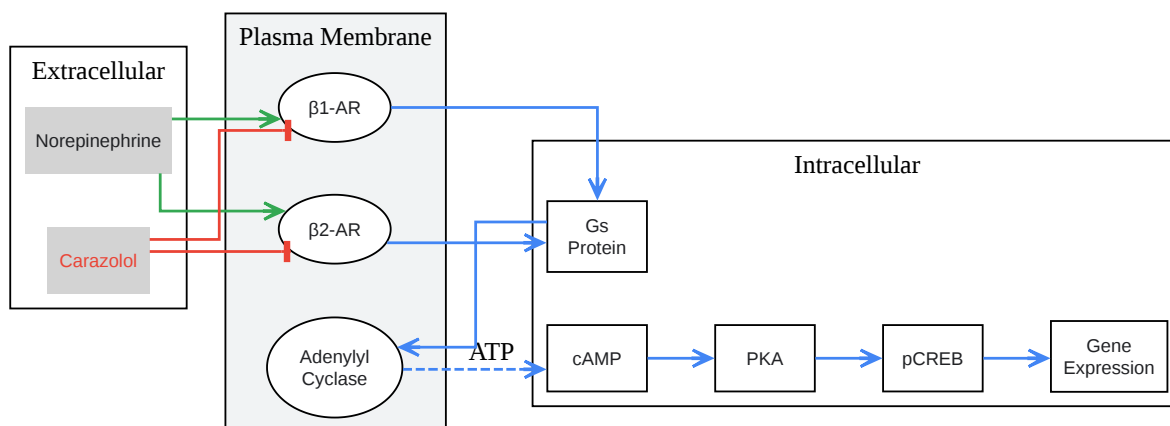

[Click to download full resolution via product page](#)

**Carazolol's** antagonism of  $\beta$ 1/ $\beta$ 2-adrenergic signaling.

## Agonism of $\beta$ 3-Adrenergic Receptor Signaling

Conversely, as a  $\beta$ 3-adrenergic receptor agonist, **Carazolol** is expected to activate Gs protein-coupled signaling pathways where these receptors are expressed in the CNS. This would lead to an increase in cAMP and activation of PKA, potentially influencing neuronal function.

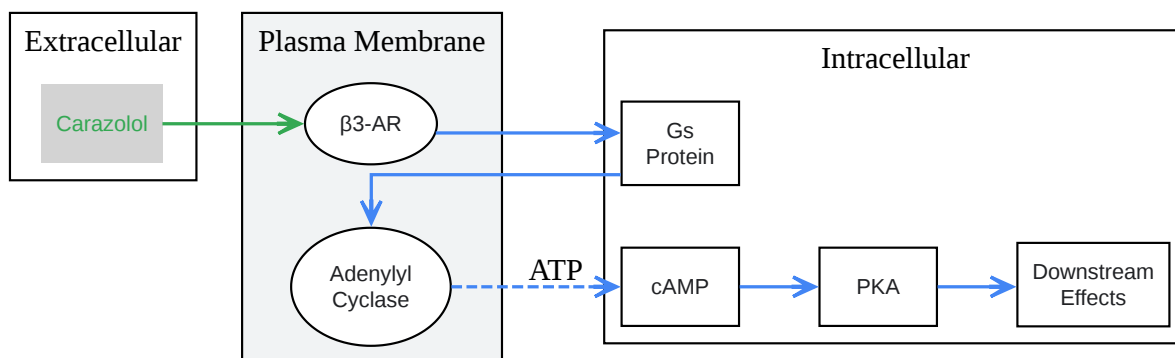

[Click to download full resolution via product page](#)

**Carazolol's** agonism of  $\beta$ 3-adrenergic signaling.

## Experimental Protocols

The following section details proposed experimental protocols for investigating the CNS effects of **Carazolol**. These are based on standard methodologies used for other  $\beta$ -adrenergic modulators.

### In Vitro Assays

This protocol determines the affinity and density of **Carazolol** binding sites in specific brain regions.

- Objective: To quantify the  $K_d$  and  $B_{max}$  of [ $^3H$ ]-**Carazolol** in rodent brain homogenates.
- Materials:
  - Rodent brain tissue (e.g., cortex, hippocampus, cerebellum)
  - [ $^3H$ ]-**Carazolol** (radioligand)
  - Unlabeled **Carazolol**
  - Binding buffer (e.g., 50 mM Tris-HCl, 10 mM MgCl<sub>2</sub>, pH 7.4)
  - Scintillation fluid and vials
  - Liquid scintillation counter
  - Glass fiber filters
  - Filtration manifold
- Procedure:
  - Prepare brain tissue homogenates in ice-cold binding buffer.
  - For saturation binding, incubate aliquots of homogenate with increasing concentrations of [ $^3H$ ]-**Carazolol**.

- For competition binding, incubate homogenates with a fixed concentration of [3H]-**Carazolol** and increasing concentrations of unlabeled **Carazolol**.
- Incubate at room temperature for a predetermined time to reach equilibrium.
- Terminate the reaction by rapid filtration through glass fiber filters.
- Wash filters with ice-cold binding buffer to remove unbound radioligand.
- Measure radioactivity on the filters using a liquid scintillation counter.
- Data Analysis:
  - Saturation binding data are analyzed using Scatchard plots to determine Kd and Bmax.
  - Competition binding data are analyzed to calculate the IC50, from which the Ki can be derived using the Cheng-Prusoff equation.

This assay measures the functional consequence of **Carazolol**'s interaction with  $\beta$ -adrenergic receptors on a key downstream effector.

- Objective: To determine the effect of **Carazolol** on basal and agonist-stimulated adenylyl cyclase activity in cultured neuronal cells or brain tissue.
- Materials:
  - Cultured neuronal cells (e.g., primary cortical neurons, SH-SY5Y cells) or brain tissue homogenates
  - **Carazolol**
  - $\beta$ -adrenergic agonist (e.g., Isoproterenol)
  - Assay buffer (containing ATP, Mg<sup>2+</sup>, and a phosphodiesterase inhibitor like IBMX)
  - cAMP enzyme immunoassay (EIA) kit or radioimmunoassay (RIA) kit
- Procedure:

- Pre-incubate neuronal cells or tissue homogenates with **Carazolol** at various concentrations.
- Stimulate with a  $\beta$ -adrenergic agonist (for antagonist studies) or assess basal activity (for agonist studies).
- Incubate for a defined period at 37°C.
- Terminate the reaction and lyse the cells/tissue.
- Measure the amount of cAMP produced using a commercial EIA or RIA kit.
- Data Analysis:
  - Generate dose-response curves to determine the IC50 (for antagonism) or EC50 (for agonism) of **Carazolol**.

## In Vivo Behavioral Assays

These protocols are designed to assess the potential effects of **Carazolol** on locomotor activity, anxiety, and depressive-like behavior in rodents.

- Objective: To evaluate the effects of **Carazolol** on general locomotor activity and anxiety-like behavior.
- Apparatus: A square arena with walls, typically equipped with automated tracking software.
- Procedure:
  - Administer **Carazolol** or vehicle to rodents at various doses.
  - After a specified pre-treatment time, place the animal in the center of the open field arena.
  - Allow the animal to explore freely for a set duration (e.g., 10-30 minutes).
  - Record and analyze parameters such as total distance traveled, time spent in the center versus the periphery, and rearing frequency.
- Data Analysis:

- Compare the behavioral parameters between **Carazolol**-treated and vehicle-treated groups using appropriate statistical tests (e.g., ANOVA). A decrease in total distance traveled may suggest sedative effects, while an increase in the time spent in the center may indicate anxiolytic-like effects.
- Objective: To assess the anxiolytic or anxiogenic potential of **Carazolol**.
- Apparatus: A plus-shaped maze elevated from the floor, with two open and two enclosed arms.
- Procedure:
  - Administer **Carazolol** or vehicle to rodents.
  - Place the animal in the center of the maze, facing an open arm.
  - Allow the animal to explore the maze for a fixed period (e.g., 5 minutes).
  - Record the time spent in and the number of entries into the open and closed arms.
- Data Analysis:
  - Calculate the percentage of time spent and entries into the open arms. An increase in these parameters is indicative of an anxiolytic-like effect.

## Visualization of Experimental Workflows

### General Workflow for In Vivo Behavioral Testing



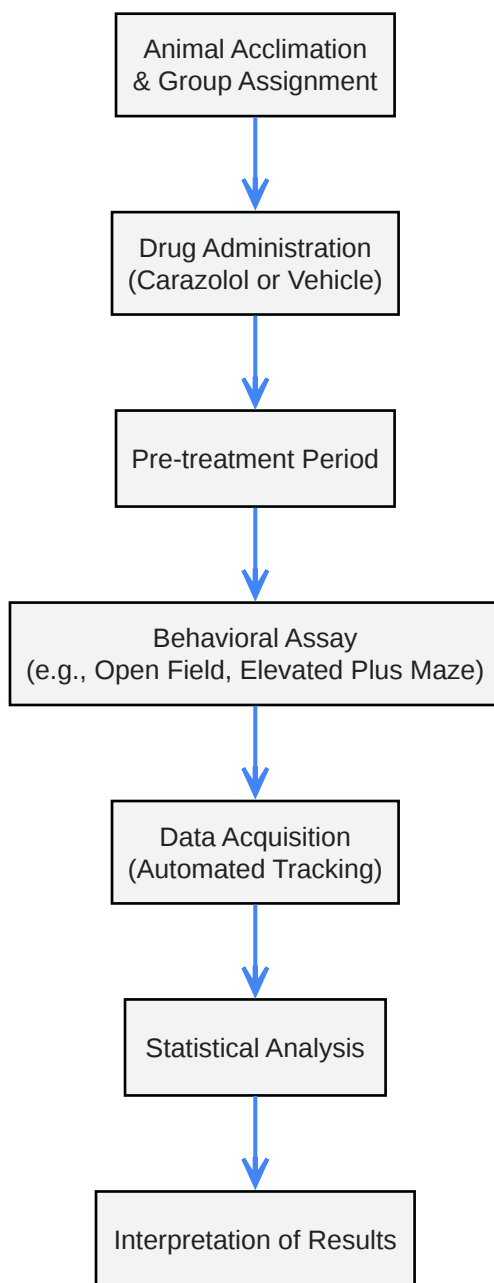

[Click to download full resolution via product page](#)

Workflow for in vivo behavioral assessment of **Carazolol**.

## Conclusion

**Carazolol**'s unique pharmacological profile as a high-affinity, non-selective  $\beta_1/\beta_2$ -adrenergic antagonist and  $\beta_3$ -adrenergic agonist, combined with its lipophilicity, strongly suggests the potential for significant effects on the central nervous system. The data presented in this guide on its receptor binding affinities provide a quantitative basis for these potential interactions. The

outlined signaling pathways offer a framework for understanding the molecular mechanisms through which **Carazolol** may exert its neuropharmacological effects.

While direct experimental evidence for **Carazolol**'s CNS effects in preclinical and clinical settings is currently lacking, the detailed experimental protocols provided herein offer a clear roadmap for future investigations. Such studies are essential to fully characterize the neuropharmacological profile of **Carazolol**, which could unveil novel therapeutic opportunities for this compound in the realm of neurological and psychiatric disorders. Further research is warranted to explore these possibilities and to establish a comprehensive understanding of **Carazolol**'s role within the central nervous system.

#### *Need Custom Synthesis?*

*BenchChem offers custom synthesis for rare earth carbides and specific isotopic labeling.*

*Email: [info@benchchem.com](mailto:info@benchchem.com) or [Request Quote Online](#).*

## References

- 1. Everything You Always Wanted to Know about  $\beta$ 3-AR \* (\* But Were Afraid to Ask) - PMC [pmc.ncbi.nlm.nih.gov]
- 2. A high-performance liquid chromatography assay of brain adenylate cyclase using [3H]ATP as substrate - PubMed [pubmed.ncbi.nlm.nih.gov]
- 3. Carazolol: a potent, selective beta 3-adrenoceptor agonist - PubMed [pubmed.ncbi.nlm.nih.gov]
- 4. apexbt.com [apexbt.com]
- To cite this document: BenchChem. [Carazolol's Effects on the Central Nervous System: A Technical Guide]. BenchChem, [2025]. [Online PDF]. Available at: [https://www.benchchem.com/product/b1668300#investigating-carazolol-s-effects-on-the-central-nervous-system]

---

#### **Disclaimer & Data Validity:**

The information provided in this document is for Research Use Only (RUO) and is strictly not intended for diagnostic or therapeutic procedures. While BenchChem strives to provide

accurate protocols, we make no warranties, express or implied, regarding the fitness of this product for every specific experimental setup.

**Technical Support:** The protocols provided are for reference purposes. Unsure if this reagent suits your experiment? [[Contact our Ph.D. Support Team for a compatibility check](#)]

**Need Industrial/Bulk Grade?** [Request Custom Synthesis Quote](#)

## BenchChem

Our mission is to be the trusted global source of essential and advanced chemicals, empowering scientists and researchers to drive progress in science and industry.

### Contact

Address: 3281 E Guasti Rd

Ontario, CA 91761, United States

Phone: (601) 213-4426

Email: [info@benchchem.com](mailto:info@benchchem.com)