

CCT68127 effects on cell cycle progression

Author: BenchChem Technical Support Team. **Date:** April 2026

Compound of Interest

Compound Name:	CCT68127
CAS No.:	660822-23-1
Cat. No.:	B1668746

[Get Quote](#)

An In-depth Technical Guide on the Effects of **CCT68127** on Cell Cycle Progression

Introduction

CCT68127 is a potent, orally active, second-generation small molecule inhibitor targeting cyclin-dependent kinases (CDKs), primarily CDK2 and CDK9.[1][2][3] Developed as a more potent and metabolically stable analog of the purine-based inhibitor seliciclib (R-roscovitine), **CCT68127** has demonstrated significant anti-proliferative and pro-apoptotic activity across a range of cancer cell lines.[1][4] Its mechanism of action, centered on the disruption of fundamental cell cycle and transcriptional machinery, makes it a compound of high interest for researchers, scientists, and drug development professionals in oncology. This guide provides a comprehensive overview of the molecular and cellular effects of **CCT68127**, with a specific focus on its impact on cell cycle progression, supported by quantitative data, detailed experimental protocols, and pathway visualizations.

Core Mechanism of Action

CCT68127 exerts its anti-cancer effects by inhibiting two key cyclin-dependent kinases that play critical roles in cell cycle regulation and transcription.

- **CDK2 Inhibition:** CDK2, in complex with Cyclin E and Cyclin A, is a crucial regulator of the G1 to S phase transition.[5][6] A primary function of the CDK2/Cyclin E complex is the phosphorylation of the Retinoblastoma protein (Rb).[1][6] Phosphorylation of Rb leads to the release of the E2F transcription factor, which activates the transcription of genes essential for DNA synthesis and S-phase entry.[1][6] By inhibiting CDK2, **CCT68127** prevents Rb phosphorylation, maintaining Rb in its active, E2F-bound state. This effectively blocks the G1/S transition, leading to cell cycle arrest.[1][2]
- **CDK9 Inhibition:** CDK9 is a component of the positive transcription elongation factor b (P-TEFb) complex. This complex phosphorylates the C-terminal domain of RNA Polymerase II (RNA Pol II), an event that is critical for releasing it from promoter-proximal pausing and enabling productive transcriptional elongation.[1] Inhibition of CDK9 by **CCT68127** leads to reduced phosphorylation of RNA Pol II, which in turn causes the transcriptional repression of key survival proteins, many of which have short half-lives.[1][2] These include anti-apoptotic proteins like MCL1 and oncogenes such as MYCN, contributing to both cell cycle arrest and apoptosis.[1][4]

Effects on Cell Cycle Progression

Treatment of cancer cells with **CCT68127** leads to significant perturbations in cell cycle distribution, primarily manifesting as cell cycle arrest and, in specific contexts, a form of mitotic catastrophe.

1. **Induction of G1 and G2/M Arrest:** Commensurate with its role as a CDK2 inhibitor, **CCT68127** effectively induces cell cycle arrest. In various lung cancer cell lines, treatment with **CCT68127** has been shown to cause a significant accumulation of cells in either the G1 or G2/M phase of the cell cycle.[5][7] For example, studies have documented G1 arrest in ED1, LKR13, and Hop62 lung cancer cells, while G2/M arrest was observed in H522 cells following treatment.[5] This arrest prevents cancer cells from proceeding with DNA replication and division, thereby inhibiting proliferation.
2. **Anaphase Catastrophe:** A notable effect of **CCT68127** is the induction of "anaphase catastrophe" in cancer cells characterized by aneuploidy and supernumerary centrosomes, a common feature in lung cancer.[7][8] Anaphase catastrophe is a form of cell death that occurs when cells fail to properly cluster their extra centrosomes during mitosis, leading to multipolar anaphase and subsequent apoptosis.[8] **CCT68127** was found to inhibit the clustering of

supernumerary centrosomes, leading to a 14.1% increase in anaphase catastrophe at a 1 μ M concentration.[7] This mechanism provides a targeted therapeutic window, as it has minimal effects on normal, non-aneuploid cells.[8]

Signaling Pathway Visualizations

The following diagrams illustrate the key signaling pathways disrupted by **CCT68127**.

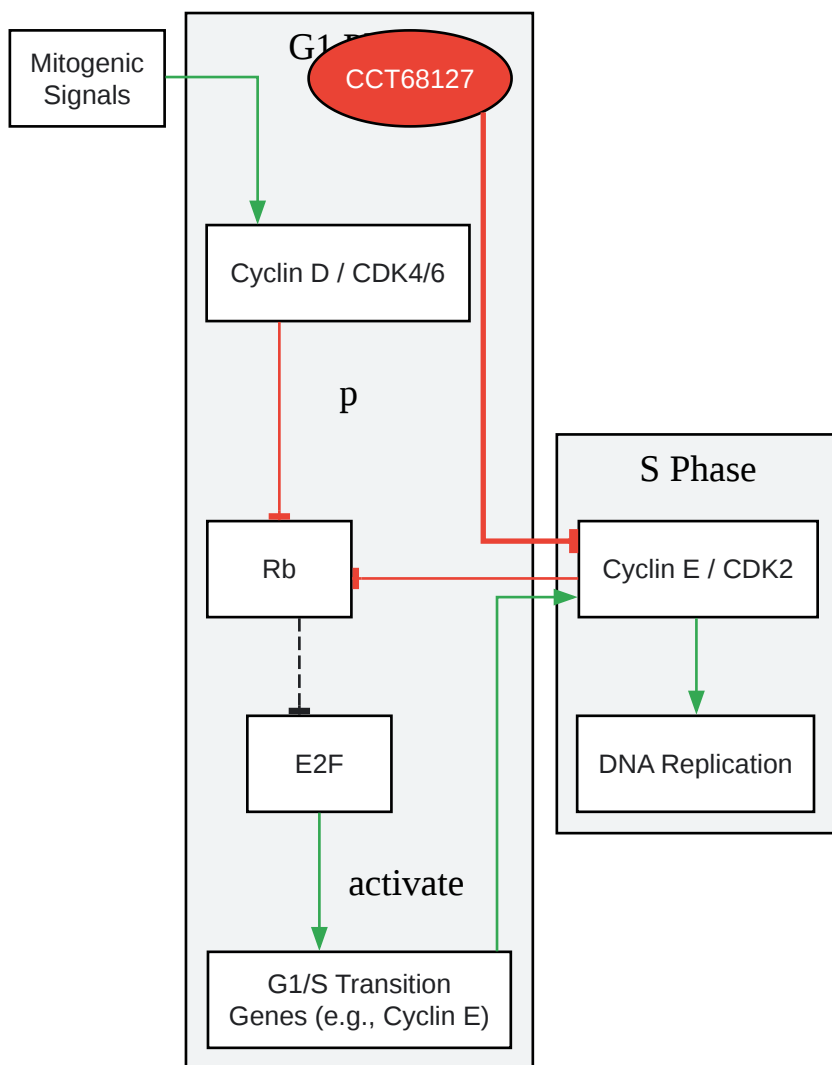

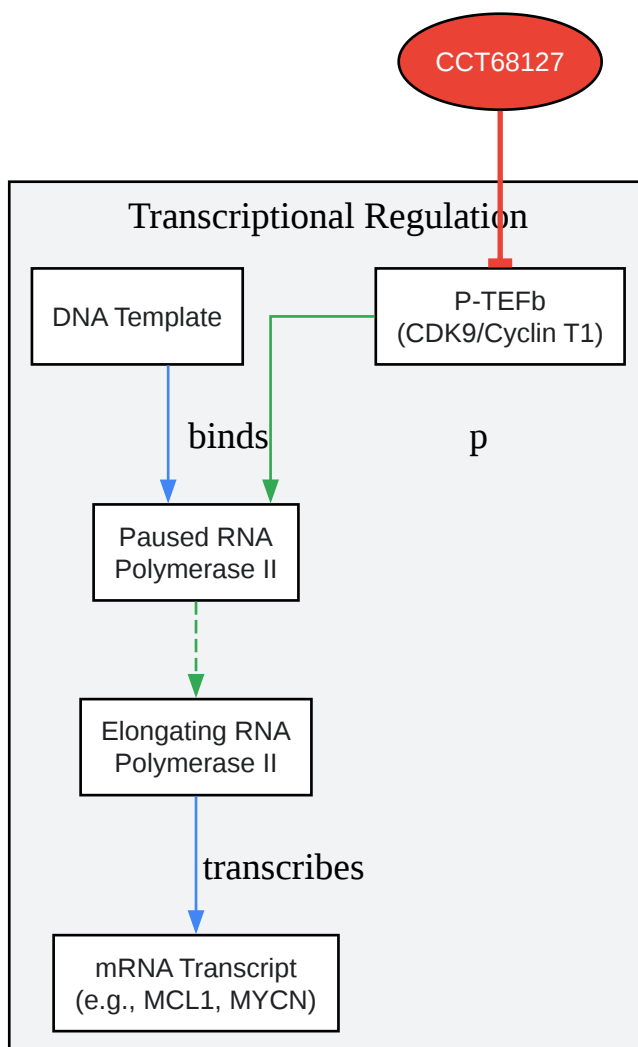

[Click to download full resolution via product page](#)

Need Custom Synthesis?

BenchChem offers custom synthesis for rare earth carbides and specific isotopic labeling.

Email: info@benchchem.com or [Request Quote Online](#).

References

- [1. Molecular profiling and combinatorial activity of CCT068127: a potent CDK2 and CDK9 inhibitor - PMC \[pmc.ncbi.nlm.nih.gov\]](#)
- [2. Molecular profiling and combinatorial activity of CCT068127: a potent CDK2 and CDK9 inhibitor - PubMed \[pubmed.ncbi.nlm.nih.gov\]](#)
- [3. medchemexpress.com \[medchemexpress.com\]](#)
- [4. cyclacel.com \[cyclacel.com\]](#)
- [5. Next-Generation CDK2/9 Inhibitors and Anaphase Catastrophe in Lung Cancer - PMC \[pmc.ncbi.nlm.nih.gov\]](#)
- [6. benchchem.com \[benchchem.com\]](#)
- [7. Next-Generation CDK2/9 Inhibitors and Anaphase Catastrophe in Lung Cancer - PubMed \[pubmed.ncbi.nlm.nih.gov\]](#)
- [8. Lung cancer cells susceptible to inhibitor treatment via newly discovered pathway | MD Anderson Cancer Center \[mdanderson.org\]](#)
- [To cite this document: BenchChem. \[CCT68127 effects on cell cycle progression\]. BenchChem, \[2026\]. \[Online PDF\]. Available at: \[https://www.benchchem.com/product/b1668746/docs#cct68127-effects-on-cell-cycle-progression\]](#)

Disclaimer & Data Validity:

The information provided in this document is for Research Use Only (RUO) and is strictly not intended for diagnostic or therapeutic procedures. While BenchChem strives to provide accurate protocols, we make no warranties, express or implied, regarding the fitness of this product for every specific experimental setup.

Technical Support: The protocols provided are for reference purposes. Unsure if this reagent suits your experiment?

Need Industrial/Bulk Grade? [Request Custom Synthesis Quote](#)

BenchChem

Our mission is to be the trusted global source of essential and advanced chemicals, empowering scientists and researchers to drive progress in science and industry.

Contact

Address: 3281 E Guasti Rd

Ontario, CA 91761, United States

Phone: (601) 213-4426

Email: info@benchchem.com

[Contact our Ph.D. Support Team for a compatibility check](#)