

Technical Support Center: Propargyl Groups in Click Chemistry

Author: BenchChem Technical Support Team. **Date:** April 2026

Compound of Interest

Compound Name: *Bis-propargyl-PEG6*

Cat. No.: *B1667523*

[Get Quote](#)

Welcome to the technical support center for researchers, scientists, and drug development professionals utilizing propargyl groups in copper-catalyzed azide-alkyne cycloaddition (CuAAC) click chemistry. This guide provides troubleshooting advice and frequently asked questions (FAQs) to help you navigate and resolve common side reactions and challenges encountered during your experiments.

Frequently Asked Questions (FAQs)

Q1: What are the most common side reactions involving propargyl groups during a CuAAC (click) reaction?

A1: The most prevalent side reaction is the oxidative homocoupling of the terminal alkyne, known as Glaser, Eglinton, or Hay coupling.^{[1][2]} This reaction leads to the formation of a symmetric 1,3-diyne byproduct, which can significantly reduce the yield of your desired triazole product.^[1] Other potential side reactions include:

- Copper-acetylide formation: Terminal alkynes react with copper(I) ions to form copper acetylide intermediates, which are essential for the click reaction.^[3] However, these can sometimes lead to the formation of unproductive polymeric copper acetylide aggregates,

especially in non-polar organic solvents.[3] When isolated and dried, copper acetylides can be explosive.

- Propargyl group degradation: Under certain conditions, such as high temperatures or the presence of strong acids, propargyl groups can degrade. For example, propargyl alcohol can undergo acid-catalyzed hydrolysis to form various byproducts.
- Isomerization to allenes: Propargyl derivatives may rearrange to form isomeric allenes, particularly when exposed to heat or certain catalysts.
- Copper-induced fragmentation: Certain propargyl-containing molecules, such as tertiary propargyl carbamates, are susceptible to fragmentation in the presence of copper, making them unsuitable for CuAAC reactions.

Q2: I am observing a significant amount of a dimerized byproduct in my reaction. What is causing this and how can I prevent it?

A2: The formation of a dimerized byproduct is a classic sign of Glaser coupling, the oxidative homocoupling of your propargyl-containing molecule. This side reaction is catalyzed by copper ions in the presence of an oxidant, typically oxygen from the air.

Here are several strategies to minimize or prevent Glaser coupling:

- Deoxygenate your reaction mixture: Thoroughly purge all solvents and the reaction vessel with an inert gas like argon or nitrogen before adding the copper catalyst. Maintaining an inert atmosphere throughout the reaction is crucial.
- Use a reducing agent: The addition of a mild reducing agent, most commonly sodium ascorbate, is highly effective. Sodium ascorbate maintains the copper catalyst in its active Cu(I) oxidation state and scavenges dissolved oxygen, thereby suppressing the oxidative homocoupling pathway. It is often used in slight excess relative to the copper catalyst.
- Utilize a stabilizing ligand: Ligands such as TBTA (Tris[(1-benzyl-1H-1,2,3-triazol-4-yl)methyl]amine) or THPTA (Tris(3-hydroxypropyl)triazolylmethyl)amine) can stabilize the Cu(I) catalyst, preventing its oxidation to Cu(II) which can participate in Glaser coupling.

- Control reaction temperature: While gentle heating can sometimes accelerate the desired click reaction, higher temperatures can also promote alkyne dimerization. It is advisable to run the reaction at room temperature unless optimization studies suggest otherwise.

Q3: My click reaction is sluggish or not proceeding to completion. What are the possible reasons?

A3: Several factors can contribute to a slow or incomplete CuAAC reaction:

- Inactive catalyst: The Cu(I) catalyst may have been oxidized to the inactive Cu(II) state. Ensure you are using a fresh solution of your reducing agent (e.g., sodium ascorbate) and that your reaction is properly deoxygenated.
- Poor solubility: If any of the reactants (azide, alkyne, or catalyst) are not fully dissolved, the reaction rate will be significantly reduced. Try adjusting the solvent system. Common solvent systems include t-BuOH/H₂O, DMSO, DMF, and mixtures thereof.
- Insufficient ligand: The concentration of the copper-stabilizing ligand may be too low, leading to catalyst degradation. Consider increasing the ligand concentration.
- Catalyst inhibition: Certain functional groups within your reactants can coordinate with the copper catalyst and inhibit its activity. If you suspect this is the case, increasing the catalyst loading or trying a different ligand may help.

Q4: Are there any specific propargyl derivatives that are known to be problematic in click chemistry?

A4: Yes, certain structures can be problematic. For instance, tertiary propargyl carbamates have been shown to be unsuitable for CuAAC as they can undergo copper-induced fragmentation. Also, propargyl halides like propargyl bromide can be problematic as they may react with the copper catalyst itself. It is often better to use more stable propargyl derivatives such as propargyl alcohols, ethers, or amides, which are generally highly reactive and well-behaved in CuAAC reactions.

Troubleshooting Guide

This guide provides a structured approach to resolving common issues encountered during CuAAC reactions with propargyl groups.

Problem	Possible Cause(s)	Suggested Solution(s)
Low or no yield of triazole product	1. Inactive Cu(I) catalyst (oxidized to Cu(II)). 2. Degradation of starting materials (azide or alkyne). 3. Poor solubility of reactants. 4. Insufficient ligand concentration.	1. Prepare the Cu(I) catalyst in situ from a Cu(II) salt (e.g., CuSO ₄) and a fresh solution of a reducing agent (e.g., sodium ascorbate). Ensure all solutions are deoxygenated. 2. Verify the purity and integrity of your starting materials using analytical techniques like NMR or mass spectrometry. 3. Experiment with different solvent systems (e.g., t-BuOH/H ₂ O, DMSO/H ₂ O, DMF) to ensure complete dissolution of all components. 4. Increase the concentration of the copper-stabilizing ligand (e.g., THPTA, TBTA).
Significant formation of alkyne homodimer (Glaser coupling byproduct)	1. Presence of oxygen in the reaction mixture. 2. Insufficient amount of reducing agent. 3. High reaction temperature.	1. Thoroughly deoxygenate all solvents and the reaction vessel by purging with an inert gas (e.g., argon or nitrogen). 2. Use a larger excess of sodium ascorbate (e.g., 5-10 equivalents relative to the copper catalyst). 3. Perform the reaction at room temperature. If heating is necessary, carefully monitor for byproduct formation.
Difficulty in purifying the final product	1. Co-elution of the product with the ligand or byproducts. 2. Residual copper in the product.	1. If using a water-soluble ligand like THPTA, the product can often be extracted into an organic solvent. For organic-soluble ligands like TBTA,

alternative purification methods such as precipitation or specialized chromatography may be needed. 2. Wash the crude product with a solution of a copper-chelating agent like EDTA or ammonia to remove residual copper.

Experimental Protocols

Protocol 1: General Procedure for a Small-Scale CuAAC Reaction

This protocol provides a general guideline for performing a copper-catalyzed azide-alkyne cycloaddition reaction.

Materials:

- Propargyl-functionalized molecule (1.0 eq)
- Azide-functionalized molecule (1.0-1.2 eq)
- Copper(II) sulfate pentahydrate ($\text{CuSO}_4 \cdot 5\text{H}_2\text{O}$) (0.01-0.1 eq)
- Sodium ascorbate (0.05-0.5 eq)
- Solvent (e.g., 1:1 t-BuOH/H₂O, DMF, or DMSO)

Procedure:

- In a suitable reaction vessel, dissolve the propargyl-functionalized molecule and the azide-functionalized molecule in the chosen solvent.
- Sparge the solution with an inert gas (argon or nitrogen) for 15-30 minutes to remove dissolved oxygen.
- In a separate vial, prepare a fresh stock solution of copper(II) sulfate in water.

- In another vial, prepare a fresh stock solution of sodium ascorbate in water.
- To the deoxygenated solution of the alkyne and azide, add the copper(II) sulfate solution, followed by the sodium ascorbate solution.
- Stir the reaction mixture at room temperature under an inert atmosphere.
- Monitor the reaction progress by an appropriate analytical method (e.g., TLC, LC-MS, or NMR).
- Upon completion, the reaction can be worked up by quenching with water, extracting the product with an organic solvent, and purifying by chromatography if necessary.

Protocol 2: Silyl Protection of a Terminal Alkyne to Prevent Homocoupling

In multi-step syntheses where the propargyl group might be exposed to oxidative conditions, protection of the terminal alkyne can prevent Glaser coupling.

Materials:

- Terminal alkyne (1.0 eq)
- Triethylamine (1.5 eq)
- Trimethylsilyl chloride (TMSCl) (1.2 eq)
- Anhydrous solvent (e.g., THF or DCM)

Procedure:

- Dissolve the terminal alkyne in the anhydrous solvent under an inert atmosphere.
- Cool the solution to 0 °C in an ice bath.
- Add triethylamine to the solution, followed by the slow, dropwise addition of trimethylsilyl chloride.

- Allow the reaction mixture to warm to room temperature and stir for 2-4 hours.
- Monitor the reaction by TLC or GC/MS until the starting material is consumed.
- Quench the reaction by adding a saturated aqueous solution of ammonium chloride (NH₄Cl).
- Extract the product with a suitable organic solvent (e.g., diethyl ether).
- Wash the organic layer with water and brine, then dry over anhydrous magnesium sulfate, filter, and concentrate under reduced pressure to yield the silyl-protected alkyne.

Data Summary

Table 1: Relative Reactivity of Terminal Alkynes in CuAAC

The structure of the alkyne can have a modest impact on the rate of the CuAAC reaction. Propargyl derivatives consistently show high reactivity.

Alkyne Substrate	Functional Group Type	% Conversion (30 min, 10 μ M Cu ⁺)	Notes
Propargyl alcohol	Propargylic	~90%	Standard, highly reactive, and cost-effective.
Propargyl ether	Propargylic	~85-90%	Excellent reactivity, commonly used in bioconjugation.
Propargyl amide	Propargylic	~90%	High reactivity, comparable to other propargyl groups.
Phenylacetylene	Aryl alkyne	~80%	Slightly less reactive than propargyl groups.
Propiolamide	Electron-activated	>95%	Marginally more reactive but can be prone to Michael addition side reactions.
Tertiary propargyl carbamate	Propargylic	Low	Unsuitable for CuAAC due to copper-induced fragmentation.

Data adapted from comparative studies under standardized ligand-accelerated conditions.

Visualizations

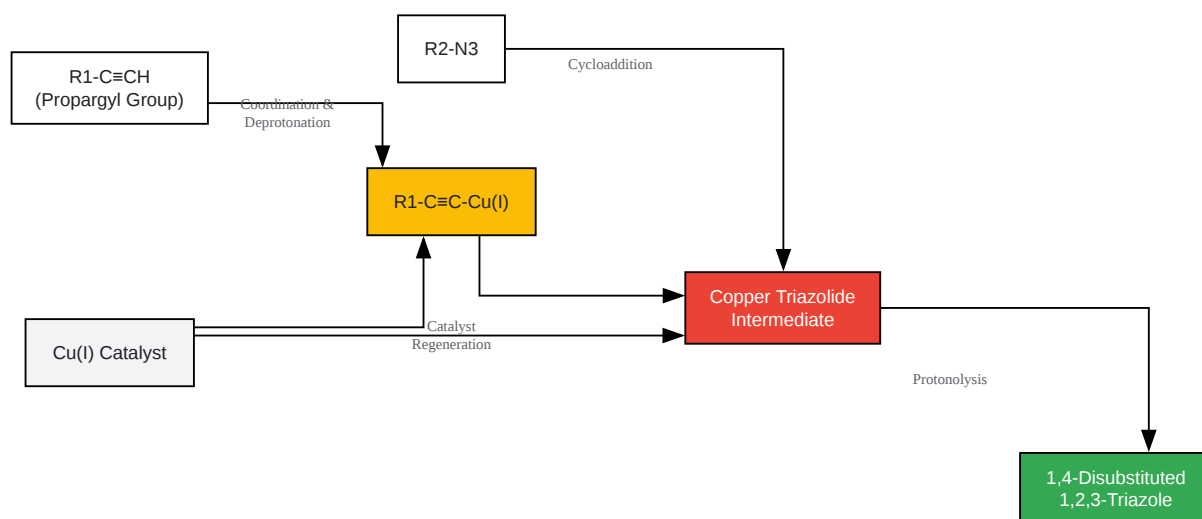

[Click to download full resolution via product page](#)

Caption: Catalytic cycle of the Copper-Catalyzed Azide-Alkyne Cycloaddition (CuAAC).

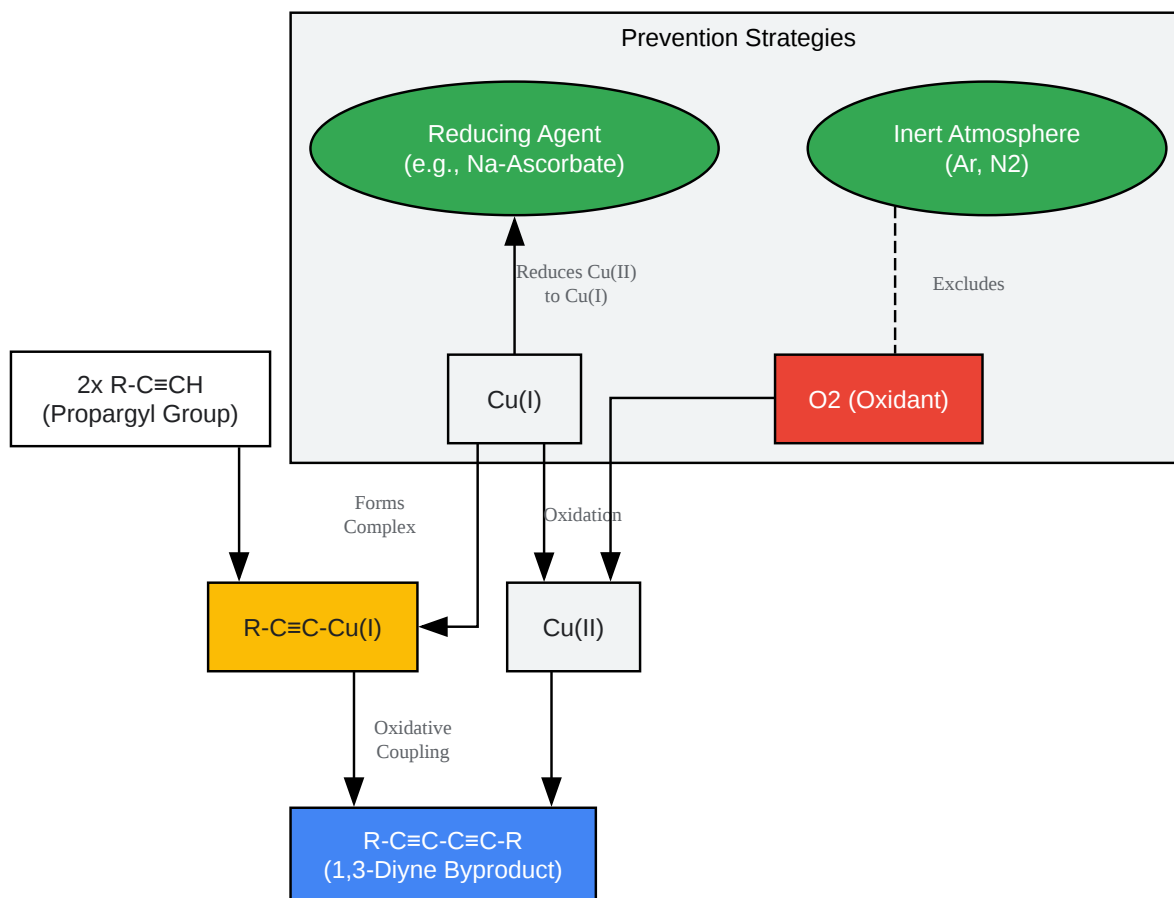

[Click to download full resolution via product page](#)

Caption: The Glaser coupling side reaction and key prevention strategies.

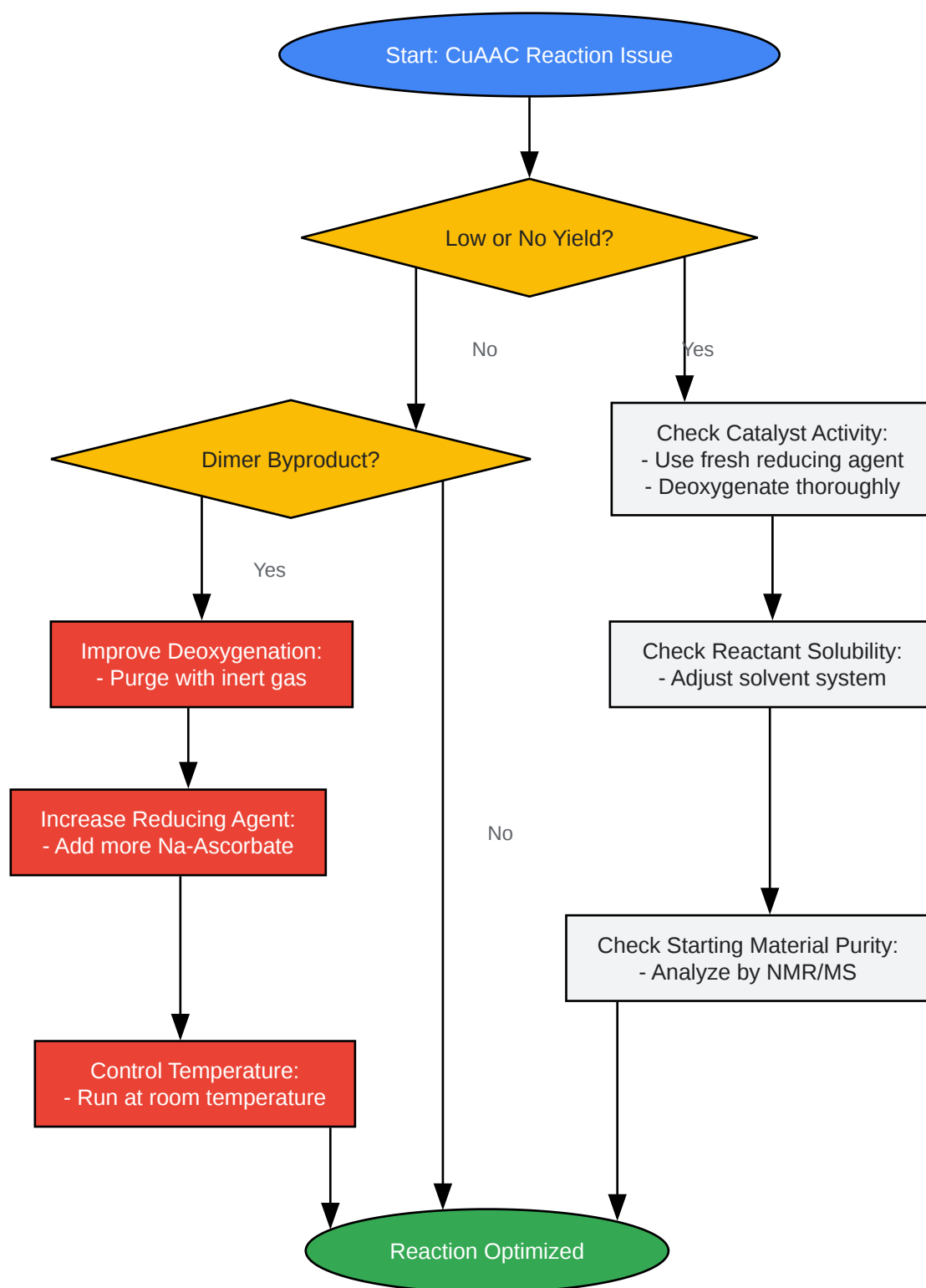

[Click to download full resolution via product page](#)

Caption: A logical workflow for troubleshooting common CuAAC reaction issues.

Need Custom Synthesis?

BenchChem offers custom synthesis for rare earth carbides and specific isotopic labeling.

Email: info@benchchem.com or [Request Quote Online](#).

References

- [1. benchchem.com \[benchchem.com\]](https://www.benchchem.com)
- [2. alfa-chemistry.com \[alfa-chemistry.com\]](https://www.alfa-chemistry.com)
- [3. Copper-catalyzed azide–alkyne cycloaddition \(CuAAC\) and beyond: new reactivity of copper\(i\) acetylides - PMC \[pmc.ncbi.nlm.nih.gov\]](#)
- To cite this document: BenchChem. [Technical Support Center: Propargyl Groups in Click Chemistry]. BenchChem, [2026]. [Online PDF]. Available at: [\[https://www.benchchem.com/product/b1667523/docs#technical-support-center-propargyl-groups-in-click-chemistry\]](https://www.benchchem.com/product/b1667523/docs#technical-support-center-propargyl-groups-in-click-chemistry)

Disclaimer & Data Validity:

The information provided in this document is for Research Use Only (RUO) and is strictly not intended for diagnostic or therapeutic procedures. While BenchChem strives to provide accurate protocols, we make no warranties, express or implied, regarding the fitness of this product for every specific experimental setup.

Technical Support: The protocols provided are for reference purposes. Unsure if this reagent suits your experiment?

Need Industrial/Bulk Grade? [Request Custom Synthesis Quote](#)

BenchChem

Our mission is to be the trusted global source of essential and advanced chemicals, empowering scientists and researchers to drive progress in science and industry.

Contact

Address: 3281 E Guasti Rd

Ontario, CA 91761, United States

Phone: (601) 213-4426

Email: info@benchchem.com

[Contact our Ph.D. Support Team for a compatibility check](#)