

In Vitro Characterization of BAY 38-7271: A Technical Guide

Author: BenchChem Technical Support Team. **Date:** April 2026

Compound of Interest

Compound Name: BAY 38-7271

CAS No.: 212188-60-8

Cat. No.: B1667812

[Get Quote](#)

For Researchers, Scientists, and Drug Development Professionals

Introduction

BAY 38-7271 is a potent and selective cannabinoid receptor agonist with high affinity for both the cannabinoid receptor type 1 (CB1) and type 2 (CB2).^{[1][2]} Developed by Bayer AG, this compound has demonstrated significant neuroprotective effects in preclinical models, suggesting its potential therapeutic application in conditions such as traumatic brain injury and cerebral ischemia.^{[1][3]} This technical guide provides a comprehensive overview of the in vitro pharmacological characterization of **BAY 38-7271**, including its binding affinity, functional activity, and the signaling pathways it modulates. Detailed experimental protocols are provided to enable replication and further investigation of its properties.

Core Data Summary

The in vitro characteristics of **BAY 38-7271** have been determined through a series of binding and functional assays. The key quantitative data are summarized in the tables below for ease of comparison.

Table 1: Receptor Binding Affinity of BAY 38-7271

| Receptor | Tissue/Cell Line | Radioligand | Ki (nM) | Reference |
|------------------|------------------|---------------|-------------|-----------|
| Human CB1 | Recombinant | [3H]CP 55,940 | 2.91 | [1] |
| Human CB2 | Recombinant | [3H]CP 55,940 | 4.24 | [1] |
| Rat Brain CB1 | Native | Not Specified | 0.46 - 1.85 | [4][5] |
| Human Cortex CB1 | Native | Not Specified | 0.46 - 1.85 | [4][5] |

Table 2: Functional Activity of BAY 38-7271

| Assay Type | Receptor | Cell Line | Parameter | Value | Reference |
|--------------------|----------|---------------|------------------|--------------|-----------|
| [35S]GTPyS Binding | CB1 | Not Specified | Agonist Activity | Full Agonist | [1] |
| [35S]GTPyS Binding | CB2 | Not Specified | Agonist Activity | Full Agonist | [1] |
| Adenylyl Cyclase | CB1/CB2 | Not Specified | cAMP levels | Inhibition | |

Signaling Pathways

BAY 38-7271 exerts its effects by activating CB1 and CB2 receptors, which are G-protein coupled receptors (GPCRs). The primary signaling mechanism involves coupling to inhibitory G-proteins (Gi/o), leading to the inhibition of adenylyl cyclase and a subsequent decrease in intracellular cyclic AMP (cAMP) levels. Activation of these receptors can also lead to the modulation of various ion channels and other downstream signaling cascades, including the mitogen-activated protein kinase (MAPK) and phosphoinositide 3-kinase (PI3K)/Akt pathways.

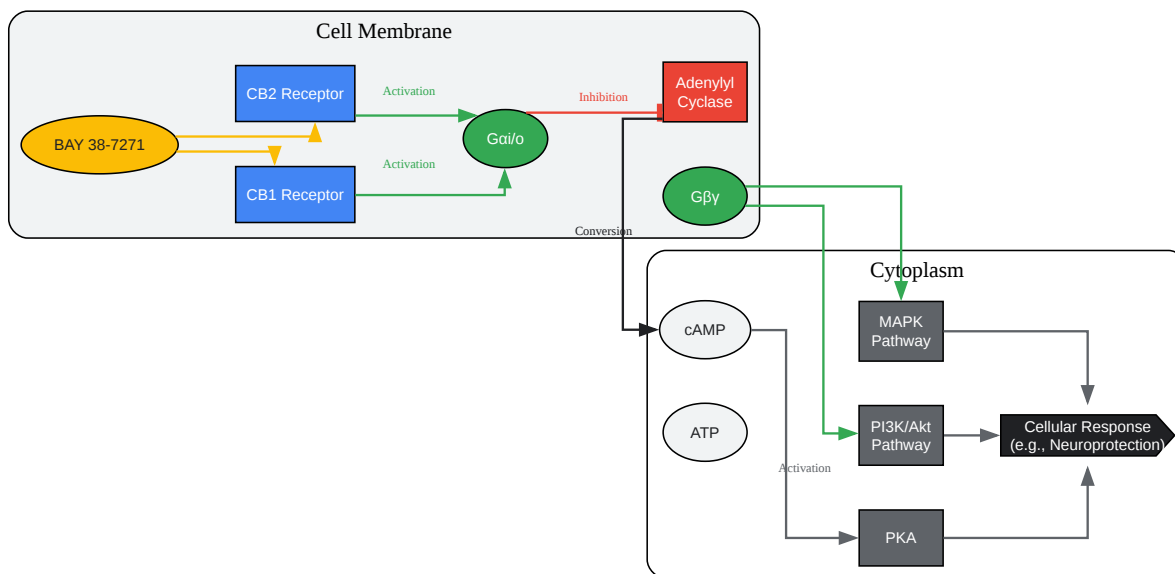

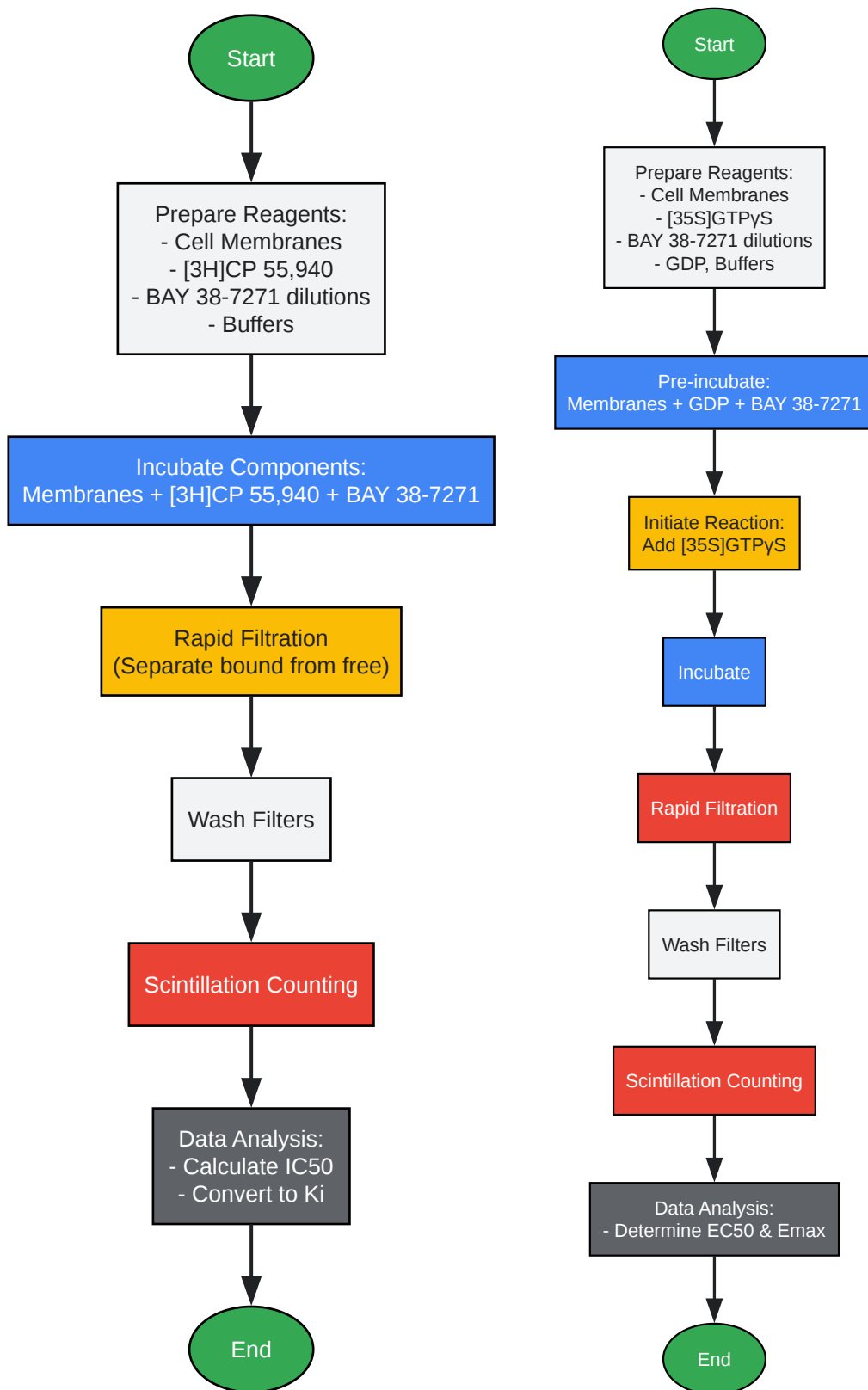

[Click to download full resolution via product page](#)

Need Custom Synthesis?

BenchChem offers custom synthesis for rare earth carbides and specific isotopic labeling.

Email: info@benchchem.com or [Request Quote Online](#).

References

- [1. researchgate.net \[researchgate.net\]](#)
- [2. BAY 38-7271 - Wikipedia \[en.wikipedia.org\]](#)
- [3. researchgate.net \[researchgate.net\]](#)
- [4. researchgate.net \[researchgate.net\]](#)
- [5. Structure–Affinity Relationships and Structure–Kinetic Relationships of 1,2-Diarylimidazol-4-carboxamide Derivatives as Human Cannabinoid 1 Receptor Antagonists - PMC \[pmc.ncbi.nlm.nih.gov\]](#)
- To cite this document: BenchChem. [In Vitro Characterization of BAY 38-7271: A Technical Guide]. BenchChem, [2026]. [Online PDF]. Available at: [\[https://www.benchchem.com/product/b1667812/docs#in-vitro-characterization-of-bay-38-7271-a-technical-guide\]](https://www.benchchem.com/product/b1667812/docs#in-vitro-characterization-of-bay-38-7271-a-technical-guide)

Disclaimer & Data Validity:

The information provided in this document is for Research Use Only (RUO) and is strictly not intended for diagnostic or therapeutic procedures. While BenchChem strives to provide accurate protocols, we make no warranties, express or implied, regarding the fitness of this product for every specific experimental setup.

Technical Support: The protocols provided are for reference purposes. Unsure if this reagent suits your experiment?

Need Industrial/Bulk Grade? [Request Custom Synthesis Quote](#)

BenchChem

Our mission is to be the trusted global source of essential and advanced chemicals, empowering scientists and researchers to drive progress in science and industry.

Contact

Address: 3281 E Guasti Rd

Ontario, CA 91761, United States

Phone: (601) 213-4426

Email: info@benchchem.com

[Contact our Ph.D. Support Team for a compatibility check](#)