

Data Presentation: Quantitative Effects of Artonin E

Author: BenchChem Technical Support Team. **Date:** April 2026

Compound of Interest

Compound Name: Artonin E
CAS No.: 129683-93-8
Cat. No.: B1667623

[Get Quote](#)

The efficacy of **Artonin E** is demonstrated through its dose- and time-dependent effects on cancer cell viability, apoptosis induction, and cell cycle progression. The following tables summarize the key quantitative data from various studies.

Table 1: Cytotoxicity of **Artonin E** (IC₅₀ Values) in Various Cancer Cell Lines

Cell Line	Cancer Type	Time Point (hours)	IC ₅₀ Value	Reference
HCT116	Colon Cancer	24	3.25 ± 0.24 µg/mL	[3]
LoVo	Colon Cancer	24	11.73 ± 1.99 µg/mL	[3]
MCF-7	Breast Cancer (ER+)	24	3.8 µM	[1]
MCF-7	Breast Cancer (ER+)	48	5.1 µM	
MCF-7	Breast Cancer (ER+)	72	6.9 µM	
MDA-MB-231	Triple-Negative Breast Cancer	24	14.3 µM	
MDA-MB-231	Triple-Negative Breast Cancer	48	13.9 µM	
MDA-MB-231	Triple-Negative Breast Cancer	72	9.8 µM	
SKOV-3	Ovarian Cancer	72	6.5 ± 0.5 µg/mL	
T1074	Normal Ovarian Cells	72	32.5 ± 0.5 µg/mL	
H460	Lung Cancer	Not Specified	31.93 µg/ml	

 Table 2: **Artonin E**-Induced Apoptosis and Related Markers

Cell Line	Treatment	Parameter	Result	Reference
MCF-7	30 μ M Artonin E (24h)	Caspase-9 Activity	Significant increase vs. control	
MCF-7	30 μ M Artonin E (24h)	Caspase-8 Activity	Significant increase vs. control	
MDA-MB-231	3, 10, 30 μ M Artonin E	Caspase-8 & -9 Activity	Dose-dependent increase	
SKOV-3	Artonin E	Caspase-3, -8, -9 Activity	Activation promoted	
LoVo	30 μ g/mL Artonin E (24h)	Sub-G1 Population	12.61%	
HCT116	2.5 μ g/mL Artonin E (24h)	Sub-G1 Population	6.80%	

 Table 3: Effect of **Artonin E** on Cell Cycle Distribution

Cell Line	Treatment	% Cells in G ₀ /G ₁ Phase	% Cells in S Phase	Reference
MCF-7	Control	57.6%	Not Specified	
MCF-7	3 μ M Artonin E	60.8%	Not Specified	
MCF-7	10 μ M Artonin E	68.7%	Not Specified	
SKOV-3	Artonin E	Not Specified	S Phase Arrest	
MDA-MB-231	Artonin E	Not Specified	G ₂ /M Arrest	

 Table 4: Induction of Reactive Oxygen Species (ROS) by **Artonin E**

Cell Line	Treatment	% of Cells with Increased ROS	Reference
MCF-7	Control	17.7%	
MCF-7	10 μ M Artonin E	47.80%	
MCF-7	30 μ M Artonin E	66.26%	
MDA-MB-231	Control	8.3%	
MDA-MB-231	3 μ M Artonin E	19.1%	
MDA-MB-231	10 μ M Artonin E	28.8%	
MDA-MB-231	30 μ M Artonin E	43.9%	

Core Mechanisms of Action

Artonin E employs a multi-pronged approach to inhibit cancer cell growth and survival, primarily through the induction of apoptosis, cell cycle arrest, and inhibition of metastasis, all orchestrated by the modulation of critical signaling pathways.

Induction of Apoptosis

Artonin E is a potent inducer of apoptosis, engaging both the intrinsic (mitochondrial) and, in some cases, the extrinsic pathways. A key initiating event is the significant elevation of intracellular Reactive Oxygen Species (ROS).

This ROS accumulation leads to a loss of mitochondrial membrane potential ($\Delta\Psi_m$), a critical step in the intrinsic apoptotic pathway. The disruption of the mitochondrial membrane facilitates the release of cytochrome c into the cytosol. This process is further amplified by **Artonin E**'s modulation of the Bcl-2 family of proteins; it upregulates the pro-apoptotic protein Bax while downregulating anti-apoptotic proteins such as Bcl-2, Bcl-xL, and Mcl-1.

The released cytochrome c, along with Apaf-1 and pro-caspase-9, forms the apoptosome, leading to the activation of caspase-9. Activated caspase-9 then triggers a cascade of effector caspases, including caspase-3 and caspase-7, which execute the final stages of apoptosis by

cleaving cellular substrates like PARP (Poly (ADP-ribose) polymerase). In certain cancer cells, such as MDA-MB-231, **Artonin E** also activates the extrinsic pathway initiator, caspase-8.

Furthermore, **Artonin E** has been shown to significantly suppress the expression of inhibitors of apoptosis proteins (IAPs) like livin and survivin, thereby lowering the threshold for apoptosis induction.

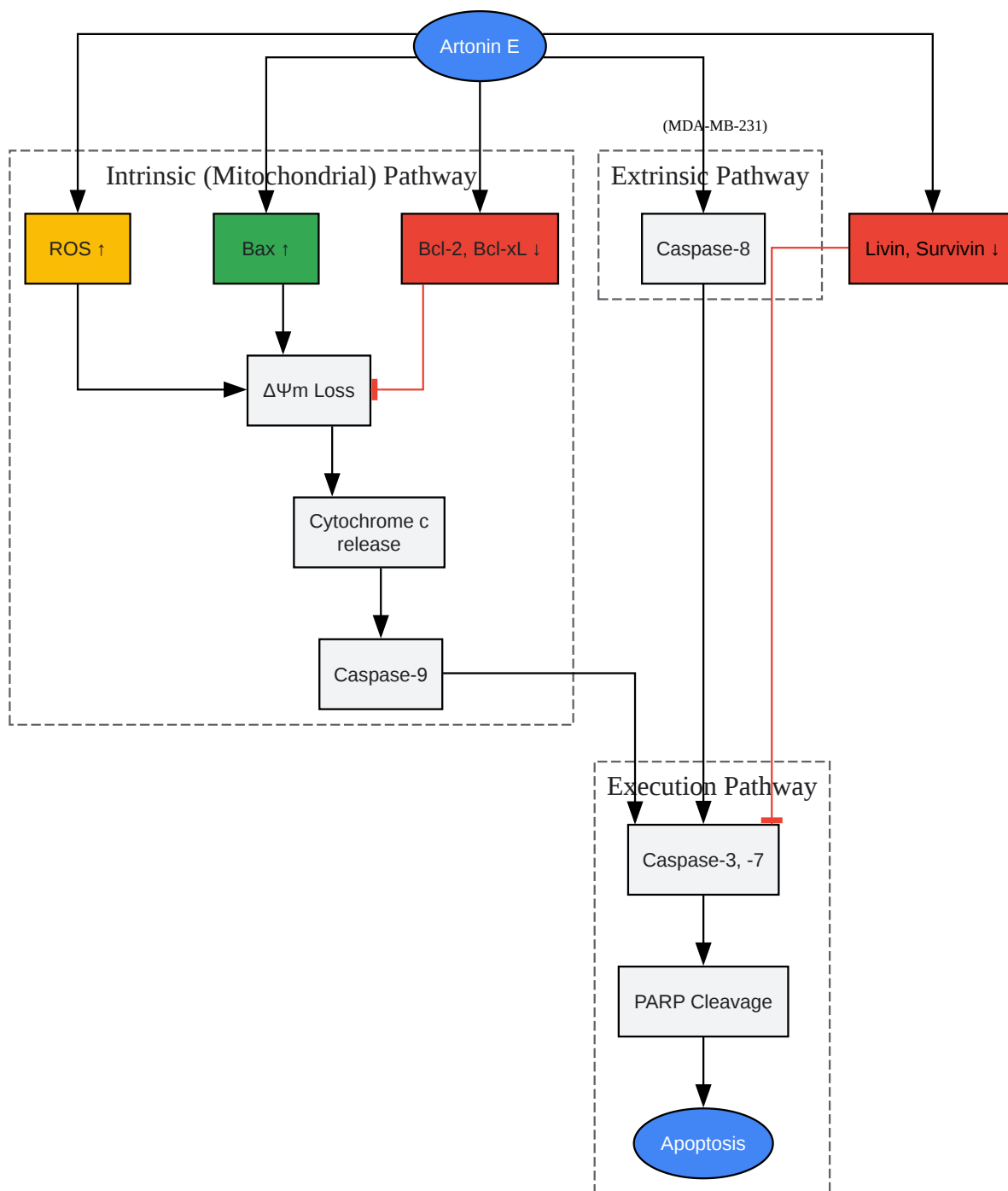

[Click to download full resolution via product page](#)

Artonin E-Induced Apoptotic Signaling Pathway.

Cell Cycle Arrest

Artonin E disrupts the normal progression of the cell cycle, an essential mechanism for its anti-proliferative effects. The specific phase of arrest appears to be cell-type dependent. For instance, in MCF-7 breast cancer cells, **Artonin E** induces a G₀/G₁ phase arrest. This is associated with the upregulation of the cyclin-dependent kinase inhibitor p21 and the downregulation of cyclin D. In contrast, studies on SKOV-3 ovarian cancer cells have reported an S phase arrest, while in MDA-MB-231 cells, a G₂/M arrest was observed. The accumulation of cells in the sub-G₁ phase, as detected by flow cytometry, is indicative of apoptotic cell death.

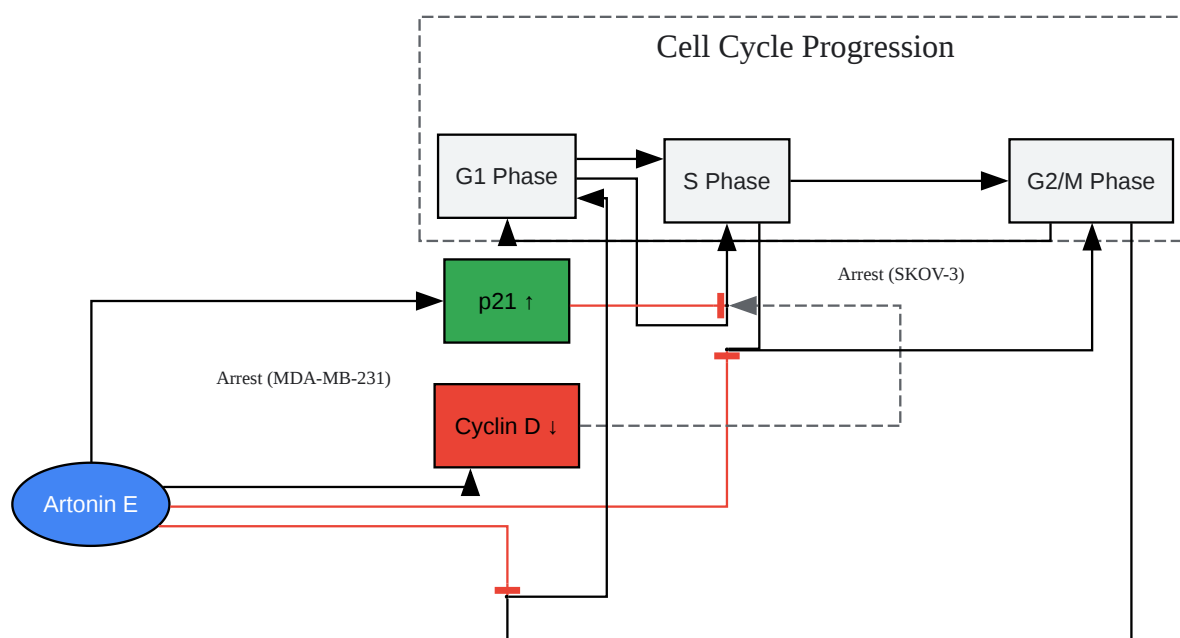

[Click to download full resolution via product page](#)

Artonin E-Induced Cell Cycle Arrest Points.

Inhibition of Metastasis and Modulation of Signaling Pathways

Artonin E has demonstrated potential in curbing the metastatic spread of cancer. It inhibits the migration and invasion of lung cancer cells by suppressing key proteins involved in cell motility. This is achieved through the decreased activation of Focal Adhesion Kinase (FAK) and its downstream effector, protein kinase B (AKT). The expression of Cell division cycle-42

(CDC42), a protein crucial for cell movement, is also reduced. Additionally, **Artonin E** enhances anoikis (detachment-induced apoptosis) in lung cancer cells, a critical mechanism for preventing metastasis, by downregulating the anti-apoptotic protein Mcl-1.

The anticancer effects of **Artonin E** are mediated through its influence on major signaling cascades. In colon cancer cells, it induces apoptosis through the activation of the MAPK signaling pathway, evidenced by increased phosphorylation of ERK1/2, p38, and c-Jun. While ERK activation is often associated with proliferation, in this context, it promotes apoptosis. Conversely, in MCF-7 cells, **Artonin E** has been reported to downregulate the MAPK pathway. This highlights the context-dependent nature of its action.

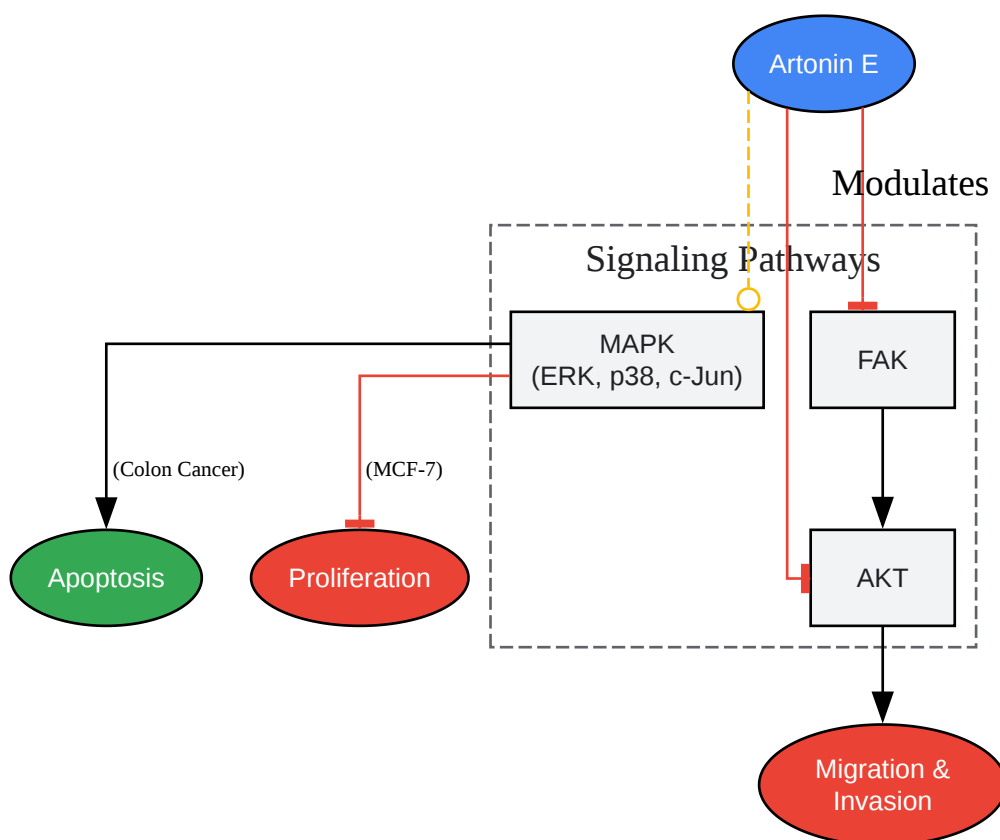

[Click to download full resolution via product page](#)

Modulation of Key Signaling Pathways by **Artonin E**.

Experimental Protocols

The following are detailed methodologies for key experiments cited in the literature for studying the effects of **Artonin E**.

Cell Viability and Cytotoxicity (MTT Assay)

- Principle: Measures the metabolic activity of viable cells. The mitochondrial dehydrogenase in living cells reduces the yellow tetrazolium salt MTT to purple formazan crystals.
- Protocol:
 - Cell Seeding: Seed cells (e.g., 5×10^3 cells/well) in a 96-well plate and allow them to adhere overnight.
 - Treatment: Treat cells with various concentrations of **Artonin E** (e.g., 0.1 to 100 $\mu\text{g/mL}$ or μM) and a vehicle control (e.g., DMSO) for specified time points (24, 48, 72 hours).
 - MTT Addition: Add 20 μL of MTT solution (5 mg/mL in PBS) to each well and incubate for 4 hours at 37°C.
 - Solubilization: Remove the medium and add 100 μL of DMSO to each well to dissolve the formazan crystals.
 - Measurement: Read the absorbance at 570 nm using a microplate reader.
 - Analysis: Calculate the percentage of cell viability relative to the control and determine the IC_{50} value using dose-response curve analysis.

Apoptosis Detection (Annexin V-FITC/PI Assay)

- Principle: Differentiates between viable, early apoptotic, late apoptotic, and necrotic cells. Annexin V binds to phosphatidylserine on the outer leaflet of the cell membrane during early apoptosis, while Propidium Iodide (PI) stains the DNA of cells with compromised membranes (late apoptotic/necrotic).
- Protocol:
 - Cell Culture and Treatment: Culture cells in a 6-well plate and treat with **Artonin E** for the desired time.
 - Harvesting: Collect both adherent and floating cells by trypsinization and centrifugation.

- Washing: Wash the cell pellet twice with cold PBS.
- Staining: Resuspend cells in 1X Binding Buffer. Add Annexin V-FITC and PI according to the manufacturer's instructions.
- Incubation: Incubate for 15 minutes at room temperature in the dark.
- Analysis: Analyze the stained cells immediately by flow cytometry.

Cell Cycle Analysis

- Principle: Quantifies the DNA content of cells to determine their distribution in the different phases of the cell cycle (G_0/G_1 , S, G_2/M). Apoptotic cells appear as a sub- G_1 peak.
- Protocol:
 - Treatment and Harvesting: Treat cells with **Artonin E**, then harvest and wash with PBS.
 - Fixation: Fix the cells by adding them dropwise into ice-cold 70% ethanol while vortexing gently. Store at -20°C overnight.
 - Staining: Centrifuge the fixed cells, wash with PBS, and resuspend in a staining solution containing Propidium Iodide (PI) and RNase A.
 - Incubation: Incubate for 30 minutes in the dark at room temperature.
 - Analysis: Analyze the DNA content by flow cytometry. The percentages of cells in each phase are determined using cell cycle analysis software.

Western Blotting

- Principle: Detects specific proteins in a sample to analyze changes in their expression or phosphorylation state.
- Protocol:
 - Protein Extraction: Lyse **Artonin E**-treated and control cells in RIPA buffer containing protease and phosphatase inhibitors.

- Quantification: Determine protein concentration using a BCA or Bradford assay.
- SDS-PAGE: Separate equal amounts of protein (e.g., 20-40 μg) on a polyacrylamide gel.
- Transfer: Transfer the separated proteins to a PVDF or nitrocellulose membrane.
- Blocking: Block the membrane with 5% non-fat milk or BSA in TBST for 1 hour.
- Antibody Incubation: Incubate the membrane with a specific primary antibody (e.g., anti-Bax, anti-Bcl-2, anti-cleaved caspase-3, anti-p-ERK) overnight at 4°C.
- Washing and Secondary Antibody: Wash the membrane with TBST and incubate with an appropriate HRP-conjugated secondary antibody for 1 hour.
- Detection: Visualize protein bands using an enhanced chemiluminescence (ECL) substrate and an imaging system.

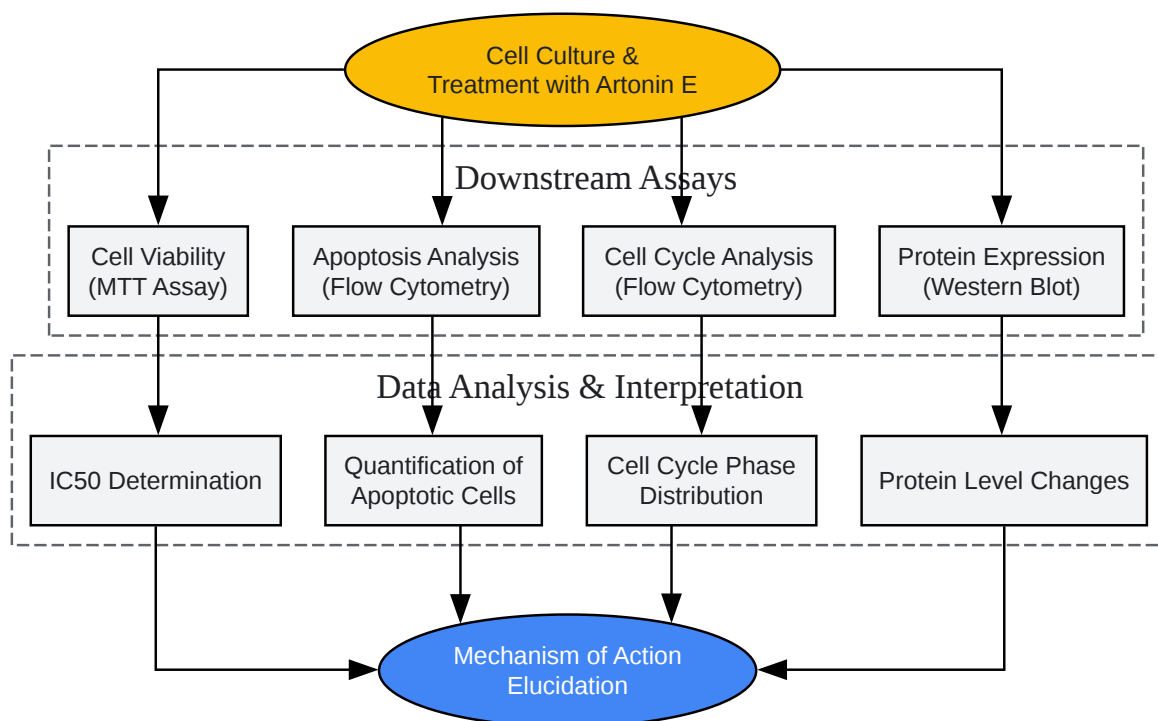

[Click to download full resolution via product page](#)

General Experimental Workflow for **Artonin E** Studies.

Conclusion

Artonin E exhibits significant anticancer activity through a sophisticated and multifaceted mechanism of action. It effectively induces apoptosis via ROS generation and modulation of the mitochondrial pathway, halts cell proliferation by inducing cell cycle arrest, and possesses the potential to inhibit metastasis. Its ability to modulate key signaling pathways, including the MAPK and Akt cascades, underscores its potential as a promising candidate for the development of novel cancer therapeutics. Further investigation in preclinical animal models is warranted to fully elucidate its therapeutic potential.

Need Custom Synthesis?

BenchChem offers custom synthesis for rare earth carbides and specific isotopic labeling.

Email: info@benchchem.com or [Request Quote Online](#).

References

- [1. Artonin E induces p53-independent G1 cell cycle arrest and apoptosis through ROS-mediated mitochondrial pathway and livin suppression in MCF-7 cells - PMC](#) [pmc.ncbi.nlm.nih.gov]
- [2. Artonin E induces p53-independent G1 cell cycle arrest and apoptosis through ROS-mediated mitochondrial pathway and livin suppression in MCF-7 cells - PubMed](#) [pubmed.ncbi.nlm.nih.gov]
- [3. mdpi.com](#) [mdpi.com]
- To cite this document: BenchChem. [Data Presentation: Quantitative Effects of Artonin E]. BenchChem, [2026]. [Online PDF]. Available at: [https://www.benchchem.com/product/b1667623/docs#data-presentation-quantitative-effects-of-artonin-e]

Disclaimer & Data Validity:

The information provided in this document is for Research Use Only (RUO) and is strictly not intended for diagnostic or therapeutic procedures. While BenchChem strives to provide accurate protocols, we make no warranties, express or implied, regarding the fitness of this product for every specific experimental setup.

Technical Support: The protocols provided are for reference purposes. Unsure if this reagent suits your experiment?

Need Industrial/Bulk Grade? [Request Custom Synthesis Quote](#)

BenchChem

Our mission is to be the trusted global source of essential and advanced chemicals, empowering scientists and researchers to drive progress in science and industry.

Contact

Address: 3281 E Guasti Rd

Ontario, CA 91761, United States

Phone: (601) 213-4426

Email: info@benchchem.com

[Contact our Ph.D. Support Team for a compatibility check](#)