

# Bryostatin 2 Structure-Activity Relationship Studies: A Technical Guide

**Author:** BenchChem Technical Support Team. **Date:** April 2026

## Compound of Interest

Compound Name: *Bryostatin 2*

CAS No.: 87745-28-6

Cat. No.: B1667956

[Get Quote](#)

For Researchers, Scientists, and Drug Development Professionals

This technical guide provides an in-depth analysis of the structure-activity relationships (SAR) of **Bryostatin 2**, a potent marine-derived macrolide. **Bryostatin 2** and its analogs are significant candidates in drug discovery due to their potent modulation of Protein Kinase C (PKC) isozymes, which are implicated in a variety of diseases, including cancer and neurological disorders. This document summarizes key quantitative data, details relevant experimental protocols, and visualizes critical biological pathways and experimental workflows to facilitate further research and development in this area.

## Core Structure-Activity Insights

**Bryostatin 2**, a structural analog of the more extensively studied Bryostatin 1, differs by the presence of a hydroxyl group at the C7 position instead of an acetoxy group. This seemingly minor modification has a significant impact on its biological activity and provides a key focal point for SAR studies. Research has demonstrated that modifications to the A-ring, and specifically the C7 and C8 positions, are critical in modulating PKC affinity and selectivity.<sup>[1][2]</sup> Furthermore, the side-chain diene system of **Bryostatin 2** has been a target for structural

modifications, with studies showing that its hydrogenation affects the compound's cytotoxic potency.[3]

The primary molecular target of bryostatins is the C1 domain of PKC.[4] Bryostatins act as potent agonists of PKC, mimicking the endogenous ligand diacylglycerol (DAG).[5] However, unlike tumor-promoting phorbol esters that also bind to the C1 domain, bryostatins exhibit a unique profile of biological activities, including antitumor properties. The differential activation and downregulation of PKC isoforms by various bryostatin analogs are key determinants of their distinct cellular responses.

## Quantitative Structure-Activity Relationship Data

The following tables summarize the quantitative data from various studies on **Bryostatin 2** and its analogs, focusing on their PKC binding affinity and cytotoxic activity.

Table 1: PKC Binding Affinity of **Bryostatin 2** and Analogs

| Compound                 | Modification   | PKC Isoform(s) | Binding Affinity (K <sub>i</sub> , nM)                       | Reference(s) |
|--------------------------|--|----------------|--|--------------|
| Bryostatin 2             | -  | Mixed          | Potent (exact K <sub>i</sub> not specified in these sources) |              |
| Analog 2                 | Simplified C7-OAc bryolog  | Mixed          | 13   |              |
| Analog 3                 | Simplified C7-OH bryolog   | Mixed          | 1000   |              |
| Analog 11                | C7 acetate bryolog   | Mixed          | 13   |              |
| Analog 17                | C7 hydroxyl bryolog  | Mixed          | (less potent than Analog 11)                                 |              |
| Merle 46                 | Diacylglycerol lactone C-ring  | PKC $\alpha$   | 7000 $\pm$ 990   |              |
| Merle 47                 | Diacylglycerol lactone C-ring  | PKC $\alpha$   | 4940 $\pm$ 470   |              |
| Merle 48                 | Diacylglycerol lactone C-ring with trans-olefin and gem-dimethyl group | PKC $\alpha$   | 363 $\pm$ 42   |              |
| [26-3H]-epi-bryostatin 4 | Inverted C-26 configuration  | Mixed          | 13 $\pm$ 2   |              |

Table 2: Cytotoxicity of **Bryostatin 2** and its Derivatives against P388 Murine Leukemia Cells

| Compound                | Modification                             | ED50 (µg/mL)                                     | Reference(s) |
|-------------------------|--|--|--------------|
| Bryostatin 2            | -  | Potent (exact ED50 not specified in this source) |              |
| Saturated Ester 2a      | Reduction of the side-chain diene system | $8.5 \times 10^{-3}$                             |              |
| Hexahydro Derivative 2b | Further hydrogenation                    | $5.1 \times 10^{-2}$                             |              |
| Octahydrobryostatin 2c  | Full hydrogenation of side-chain         | $2.9 \times 10^{-1}$                             |              |

## Experimental Protocols

Detailed methodologies are crucial for the accurate assessment and comparison of the biological activities of **Bryostatin 2** analogs. Below are outlines of key experimental protocols cited in the literature.

### Protein Kinase C (PKC) Binding Assay

This assay is fundamental to determining the affinity of **Bryostatin 2** analogs for their primary molecular target.

Objective: To quantify the binding affinity ( $K_i$ ) of test compounds to PKC.

General Principle: A competitive binding assay is typically used, where the test compound competes with a radiolabeled ligand (e.g., [ $^3\text{H}$ ]phorbol-12,13-dibutyrate, [ $^3\text{H}$ ]PDBu) for binding to a source of PKC (e.g., purified PKC isoforms, cell lysates).

Materials:

- Purified PKC isoforms or cell/tissue homogenates rich in PKC.
- Radiolabeled ligand: [ $^3\text{H}$ ]PDBu or [ $^3\text{H}$ ]bryostatin.
- Test compounds (**Bryostatin 2** and its analogs).

- Binding buffer (e.g., Tris-HCl buffer containing CaCl<sub>2</sub>, bovine serum albumin, and dithiothreitol).
- Phosphatidylserine (PS) as a cofactor.
- Glass fiber filters.
- Scintillation cocktail and liquid scintillation counter.

#### Procedure:

- Preparation of PKC: PKC can be purified from various sources, such as rat brain, or specific isoforms can be expressed and purified from recombinant systems.
- Assay Setup: In a microcentrifuge tube, combine the PKC preparation, phosphatidylserine, and the binding buffer.
- Competition: Add varying concentrations of the unlabeled test compound (**Bryostatin 2** analog) and a fixed concentration of the radiolabeled ligand. For determining non-specific binding, a high concentration of unlabeled PDBu is used.
- Incubation: Incubate the mixture at a specified temperature (e.g., 37°C) for a sufficient time to reach equilibrium.
- Separation of Bound and Free Ligand: The reaction mixture is rapidly filtered through glass fiber filters under vacuum. The filters will trap the PKC-ligand complex.
- Washing: The filters are washed with ice-cold buffer to remove any unbound radioligand.
- Quantification: The filters are placed in scintillation vials with a scintillation cocktail, and the radioactivity is measured using a liquid scintillation counter.
- Data Analysis: The amount of bound radioligand is plotted against the concentration of the test compound. The IC<sub>50</sub> value (the concentration of test compound that inhibits 50% of the specific binding of the radiolabeled ligand) is determined. The K<sub>i</sub> value is then calculated using the Cheng-Prusoff equation.

## Cytotoxicity Assay (MTT Assay)

This assay is commonly used to assess the cytostatic or cytotoxic effects of **Bryostatin 2** analogs on cancer cell lines.

Objective: To determine the concentration of a compound that inhibits cell growth by 50% (ED50 or IC50).

General Principle: The MTT (3-(4,5-dimethylthiazol-2-yl)-2,5-diphenyltetrazolium bromide) assay is a colorimetric assay that measures the metabolic activity of cells. Viable cells with active mitochondria reduce the yellow MTT to a purple formazan product. The amount of formazan produced is proportional to the number of living cells.

Materials:

- Cancer cell line of interest (e.g., P388 murine leukemia cells).
- Complete cell culture medium.
- 96-well microtiter plates.
- Test compounds (**Bryostatin 2** and its analogs).
- MTT solution (5 mg/mL in PBS).
- Solubilization solution (e.g., DMSO, acidified isopropanol).
- Microplate reader.

Procedure:

- Cell Seeding: Seed the cells in a 96-well plate at a predetermined density and allow them to adhere overnight.
- Compound Treatment: Add serial dilutions of the test compounds to the wells. Include a vehicle control (e.g., DMSO).

- Incubation: Incubate the plates for a specified period (e.g., 48 or 72 hours) at 37°C in a humidified CO<sub>2</sub> incubator.
- MTT Addition: After the incubation period, add MTT solution to each well and incubate for another 2-4 hours. During this time, viable cells will convert MTT to formazan crystals.
- Solubilization: Add the solubilization solution to each well to dissolve the formazan crystals.
- Absorbance Measurement: Measure the absorbance of the wells at a specific wavelength (typically 570 nm) using a microplate reader.
- Data Analysis: The absorbance values are plotted against the compound concentrations. The ED<sub>50</sub>/IC<sub>50</sub> value is calculated from the dose-response curve.

## Signaling Pathways and Experimental Workflows

The following diagrams, generated using the DOT language, visualize key aspects of **Bryostatin 2**'s mechanism of action and the general workflow for its SAR studies.

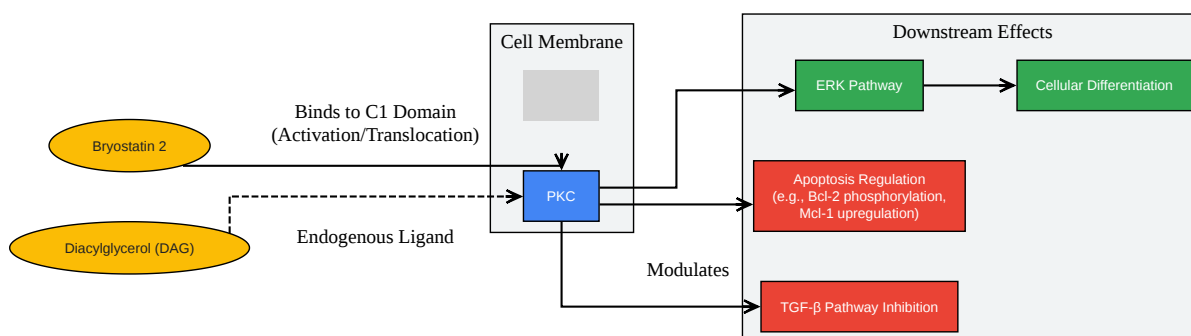

[Click to download full resolution via product page](#)

### Bryostatin 2 Signaling Pathway

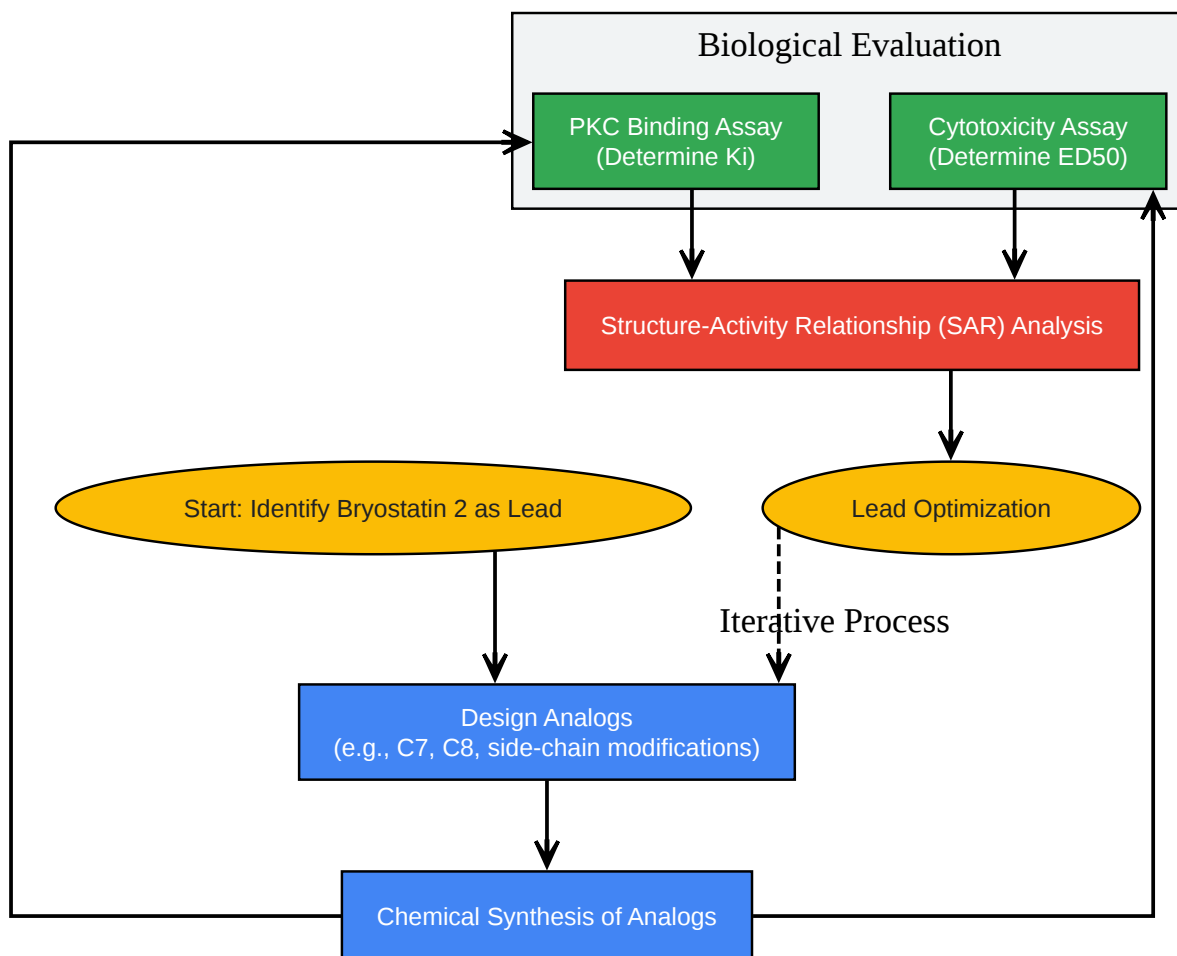

[Click to download full resolution via product page](#)

General Workflow for **Bryostatin 2** SAR Studies

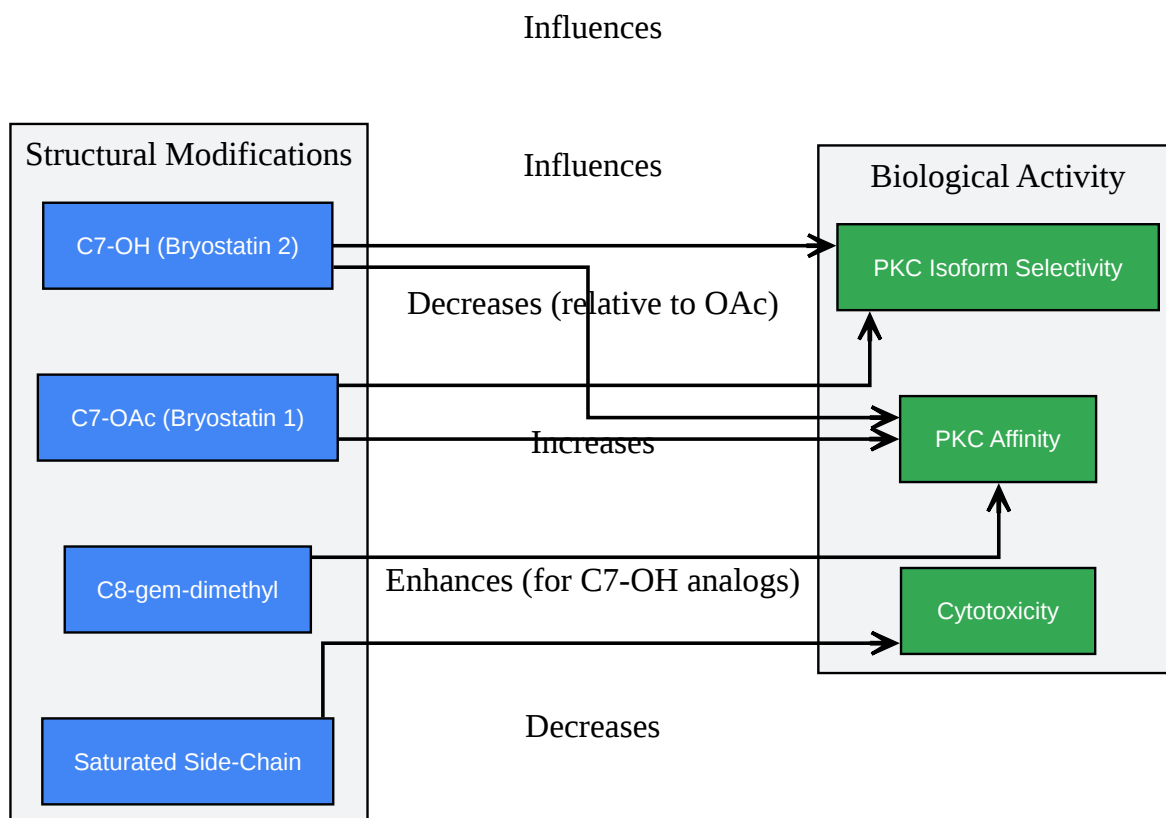

[Click to download full resolution via product page](#)

Logical Relationships in **Bryostatin 2** SAR

## Conclusion

The structure-activity relationship studies of **Bryostatin 2** have revealed critical insights into the structural requirements for potent and selective modulation of PKC. The C7 and C8 positions of the A-ring, as well as the saturation of the side-chain, are key determinants of biological activity. The quantitative data and experimental protocols provided in this guide serve as a valuable resource for researchers in the field. The visualized pathways and workflows offer a conceptual framework for understanding the mechanism of action and for guiding future drug design and development efforts based on the **Bryostatin 2** scaffold. Further exploration of **Bryostatin 2** analogs, particularly with respect to their differential effects on PKC isoforms, holds significant promise for the development of novel therapeutics.

### Need Custom Synthesis?

BenchChem offers custom synthesis for rare earth carbides and specific isotopic labeling.

Email: [info@benchchem.com](mailto:info@benchchem.com) or [Request Quote Online](#).

## References

- 1. Design, synthesis, and evaluation of potent bryostatin analogs that modulate PKC translocation selectivity - PMC [[pmc.ncbi.nlm.nih.gov](https://pubmed.ncbi.nlm.nih.gov)]
- 2. [pnas.org](https://pubmed.ncbi.nlm.nih.gov) [[pnas.org](https://pubmed.ncbi.nlm.nih.gov)]
- 3. Structural modifications of bryostatin 2 - PubMed [[pubmed.ncbi.nlm.nih.gov](https://pubmed.ncbi.nlm.nih.gov)]
- 4. Bryostatins: Biological context and biotechnological prospects - PMC [[pmc.ncbi.nlm.nih.gov](https://pubmed.ncbi.nlm.nih.gov)]
- 5. Synthesis and Biological Evaluation of Several Bryostatin Analogues Bearing a Diacylglycerol Lactone C-Ring - PMC [[pmc.ncbi.nlm.nih.gov](https://pubmed.ncbi.nlm.nih.gov)]
- To cite this document: BenchChem. [Bryostatin 2 Structure-Activity Relationship Studies: A Technical Guide]. BenchChem, [2026]. [Online PDF]. Available at: [<https://www.benchchem.com/product/b1667956/docs#bryostatin-2-structure-activity-relationship-studies-a-technical-guide>]

---

### Disclaimer & Data Validity:

The information provided in this document is for Research Use Only (RUO) and is strictly not intended for diagnostic or therapeutic procedures. While BenchChem strives to provide accurate protocols, we make no warranties, express or implied, regarding the fitness of this product for every specific experimental setup.

**Technical Support:** The protocols provided are for reference purposes. Unsure if this reagent suits your experiment?

**Need Industrial/Bulk Grade?** [Request Custom Synthesis Quote](#)

# BenchChem

Our mission is to be the trusted global source of essential and advanced chemicals, empowering scientists and researchers to drive progress in science and industry.

## Contact

Address: 3281 E Guasti Rd

Ontario, CA 91761, United States

Phone: (601) 213-4426

Email: [info@benchchem.com](mailto:info@benchchem.com)

[Contact our Ph.D. Support Team for a compatibility check](#)