

Application Notes and Protocols for Arsthinol in Cell Culture

Author: BenchChem Technical Support Team. **Date:** April 2026

Compound of Interest

Compound Name: *Arsthinol*

CAS No.: 119-96-0

Cat. No.: B1667615

[Get Quote](#)

Introduction

Arsthinol, an organoarsenic compound, has demonstrated potential as an antiprotozoal and anticancer agent.^[1] Initially synthesized in 1949, it has shown activity against various cancer cell lines, including leukemia and glioma.^{[2][3]} These application notes provide detailed protocols for the solubilization of Arsthinol, its application in cell culture experiments, and methods for assessing its cytotoxic effects. Additionally, potential signaling pathways affected by Arsthinol are discussed, providing a basis for mechanistic studies.

Data Presentation

The cytotoxic activity of Arsthinol has been evaluated in several cancer cell lines. The following table summarizes the half-maximal inhibitory concentration (IC₅₀) values from published studies.

Cell Line	Compound	IC50 (μM)	Incubation Time (hours)	Reference
NB4 (Acute Promyelocytic Leukemia)	Arsthinol	0.78 ± 0.08	24	[2]
NB4	Arsenic Trioxide (As_2O_3)	1.60 ± 0.23	24	[2]
NB4	Melarsoprol	1.44 ± 0.08	24	[2]
U87 MG (Glioblastoma)	Arsthinol-cyclodextrin complex	More effective than As_2O_3 and melarsoprol	Not Specified	[2]

Experimental Protocols

Solubilization of Arsthinol and Preparation of Stock Solutions

Arsthinol is known to be poorly soluble in aqueous solutions. Dimethyl sulfoxide (DMSO) is a suitable solvent for preparing stock solutions for in vitro experiments.[2]

Materials:

- Arsthinol powder
- Dimethyl sulfoxide (DMSO), cell culture grade
- Sterile, nuclease-free microcentrifuge tubes or vials
- Pipettes and sterile filter tips

Protocol:

- Safety Precautions: Arsthinol is an arsenic-containing compound and should be handled with appropriate safety measures, including wearing personal protective equipment (gloves, lab coat, and safety glasses). All procedures should be performed in a chemical fume hood.

- Weighing Arsthinol: Accurately weigh the desired amount of Arsthinol powder in a sterile microcentrifuge tube.
- Preparing Stock Solution:
 - Add the appropriate volume of DMSO to the Arsthinol powder to achieve the desired stock concentration (e.g., 10 mM).
 - Vortex the solution thoroughly until the Arsthinol is completely dissolved. Gentle warming at 37°C can aid dissolution.
- Sterilization: Filter the stock solution through a 0.22 µm sterile syringe filter into a new sterile tube to remove any potential microbial contamination.
- Storage: Aliquot the stock solution into smaller volumes to avoid repeated freeze-thaw cycles. Store the aliquots at -20°C for long-term storage (months) or at 4°C for short-term storage (days to weeks).[2]

Note on DMSO Concentration: The final concentration of DMSO in the cell culture medium should be kept low (typically $\leq 0.5\%$) to avoid solvent-induced cytotoxicity. A vehicle control (medium with the same concentration of DMSO as the highest Arsthinol treatment) should always be included in experiments.

Cell Viability Assay (MTT Assay)

The MTT (3-(4,5-dimethylthiazol-2-yl)-2,5-diphenyltetrazolium bromide) assay is a colorimetric assay for assessing cell metabolic activity and is commonly used to measure cytotoxicity.

Materials:

- Cells of interest
- Complete cell culture medium
- 96-well cell culture plates
- Arsthinol stock solution (dissolved in DMSO)

- MTT solution (5 mg/mL in PBS)
- DMSO or solubilization buffer (e.g., isopropanol with 0.04 N HCl)
- Phosphate-buffered saline (PBS)
- Multichannel pipette
- Microplate reader

Protocol:

- Cell Seeding: Seed cells in a 96-well plate at a predetermined optimal density and allow them to adhere overnight.
- Treatment:
 - Prepare serial dilutions of Arsthinol from the stock solution in complete cell culture medium to achieve the desired final concentrations. Remember to keep the final DMSO concentration consistent across all wells.
 - Remove the old medium from the cells and add 100 μ L of the medium containing the different concentrations of Arsthinol. Include a vehicle control (DMSO only) and an untreated control.
- Incubation: Incubate the plate for the desired treatment duration (e.g., 24, 48, or 72 hours) in a humidified incubator at 37°C and 5% CO₂.
- MTT Addition: After incubation, add 10 μ L of MTT solution to each well and incubate for 2-4 hours at 37°C.
- Formazan Solubilization:
 - Carefully remove the medium from each well.
 - Add 100 μ L of DMSO or solubilization buffer to each well to dissolve the formazan crystals.

- Mix thoroughly by gentle pipetting or by placing the plate on a shaker for 5-10 minutes.
- Absorbance Measurement: Measure the absorbance at 570 nm using a microplate reader.
- Data Analysis: Calculate the percentage of cell viability relative to the untreated control. Plot the cell viability against the Arsthinol concentration to determine the IC50 value.

Signaling Pathways and Mechanism of Action

While the precise signaling pathways of Arsthinol are still under investigation, studies on arsenic-containing compounds, particularly arsenic trioxide (ATO), provide insights into its potential mechanisms of action. Arsenic compounds are known to induce apoptosis and inhibit cell growth through various signaling pathways.

Inhibition of the Hedgehog Signaling Pathway

The Hedgehog (Hh) signaling pathway is crucial for embryonic development and is aberrantly activated in several cancers. Arsenic compounds have been shown to inhibit the Hh pathway by targeting the Gli family of transcription factors.^{[4][5][6]} This inhibition can prevent the transcription of genes involved in cell proliferation and survival.

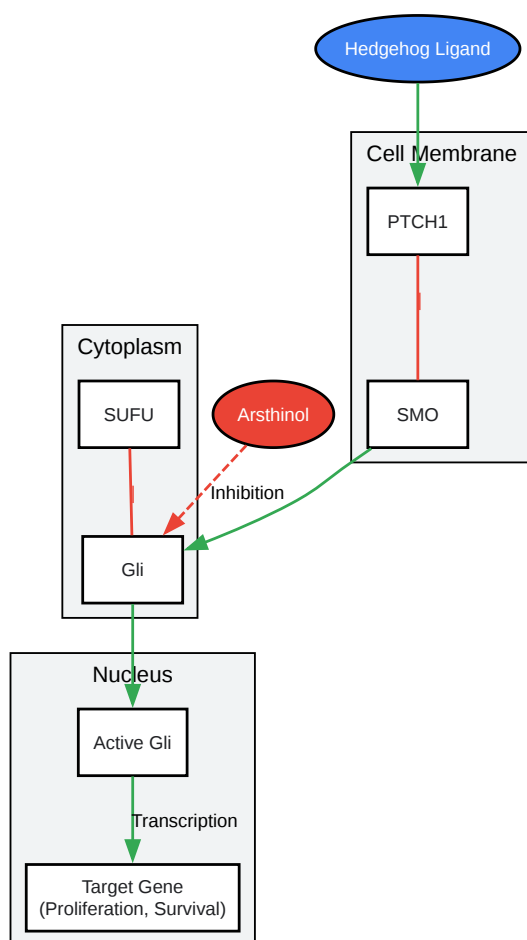

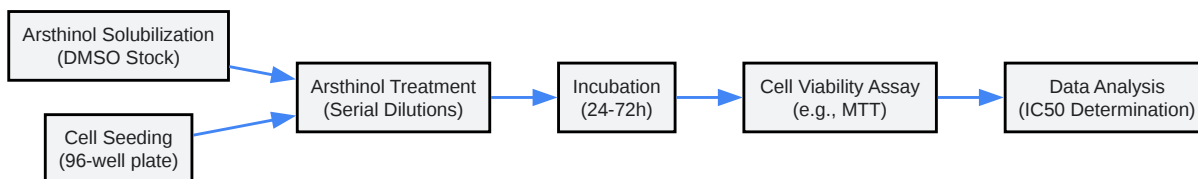
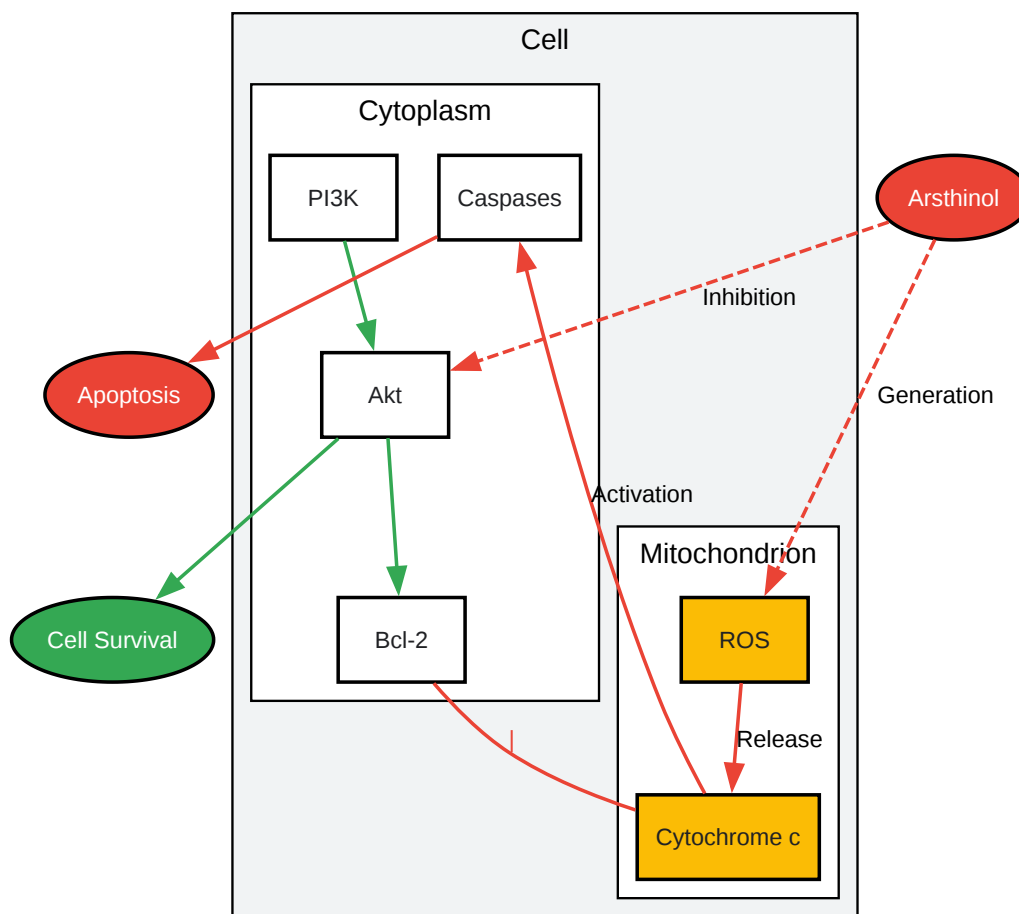

[Click to download full resolution via product page](#)

Need Custom Synthesis?

BenchChem offers custom synthesis for rare earth carbides and specific isotopic labeling.

Email: info@benchchem.com or [Request Quote Online](#).

References

- 1. Arsthinol - Wikipedia [en.wikipedia.org]

- [2. medkoo.com \[medkoo.com\]](https://www.medkoo.com)
- [3. researchgate.net \[researchgate.net\]](https://www.researchgate.net)
- [4. A new era for an ancient drug: arsenic trioxide and Hedgehog signaling - PubMed \[pubmed.ncbi.nlm.nih.gov\]](https://pubmed.ncbi.nlm.nih.gov)
- [5. Arsenic antagonizes the Hedgehog pathway by preventing ciliary accumulation and reducing stability of the Gli2 transcriptional effector - PubMed \[pubmed.ncbi.nlm.nih.gov\]](https://pubmed.ncbi.nlm.nih.gov)
- [6. Arsenic antagonizes the Hedgehog pathway by preventing ciliary accumulation and reducing stability of the Gli2 transcriptional effector - PMC \[pmc.ncbi.nlm.nih.gov\]](https://pubmed.ncbi.nlm.nih.gov)
- To cite this document: BenchChem. [Application Notes and Protocols for Arsthinol in Cell Culture]. BenchChem, [2026]. [Online PDF]. Available at: [\[https://www.benchchem.com/product/b1667615/docs#application-notes-and-protocols-for-arsthinol-in-cell-culture\]](https://www.benchchem.com/product/b1667615/docs#application-notes-and-protocols-for-arsthinol-in-cell-culture)

Disclaimer & Data Validity:

The information provided in this document is for Research Use Only (RUO) and is strictly not intended for diagnostic or therapeutic procedures. While BenchChem strives to provide accurate protocols, we make no warranties, express or implied, regarding the fitness of this product for every specific experimental setup.

Technical Support: The protocols provided are for reference purposes. Unsure if this reagent suits your experiment?

Need Industrial/Bulk Grade? [Request Custom Synthesis Quote](#)

BenchChem

Our mission is to be the trusted global source of essential and advanced chemicals, empowering scientists and researchers to drive progress in science and industry.

Contact

Address: 3281 E Guasti Rd
Ontario, CA 91761, United States
Phone: (601) 213-4426
Email: info@benchchem.com

Contact our Ph.D. Support Team for a compatibility check