

Technical Support Center: NVP-ACC789 In Vivo Bioavailability

Author: BenchChem Technical Support Team. **Date:** April 2026

Compound of Interest

Compound Name: NVP-ACC789

CAS No.: 300842-64-2

Cat. No.: B1666487

[Get Quote](#)

This technical support center provides troubleshooting guidance and frequently asked questions (FAQs) for researchers, scientists, and drug development professionals working with **NVP-ACC789**. The focus is on addressing common challenges related to its in vivo bioavailability.

Frequently Asked Questions (FAQs) & Troubleshooting

Q1: We are observing low and variable plasma concentrations of **NVP-ACC789** in our animal models after oral administration. What are the potential causes and how can we troubleshoot this?

A1: Low and variable oral bioavailability of **NVP-ACC789** is likely attributable to its poor aqueous solubility. As a crystalline solid with low solubility in aqueous solutions, its dissolution in the gastrointestinal (GI) tract may be limited, leading to poor absorption.^[1]

Troubleshooting Steps:

- Particle Size Reduction: The dissolution rate of a drug is directly related to its surface area. Reducing the particle size can significantly improve dissolution.
 - Micronization: Consider micronizing the **NVP-ACC789** powder to increase the surface area available for dissolution.[2]
 - Nanosuspension: For a more significant increase in surface area and dissolution velocity, formulating a nanosuspension can be beneficial.[2][3]
- Formulation Strategy: The formulation of the dosing vehicle is critical.
 - Solubilizing Excipients: Incorporate surfactants, co-solvents, or complexing agents (e.g., cyclodextrins) in your formulation to enhance the solubility of **NVP-ACC789**. [3][4]
 - Lipid-Based Formulations: Self-emulsifying drug delivery systems (SEDDS) or lipid-based formulations can improve absorption by presenting the drug in a solubilized state and potentially utilizing lymphatic uptake pathways.[5]
 - Amorphous Solid Dispersions: Creating an amorphous solid dispersion of **NVP-ACC789** with a polymer can prevent crystallization and maintain the drug in a higher energy state, which improves solubility and dissolution.[5]
- pH Adjustment: Investigate the pH-solubility profile of **NVP-ACC789**. Buffering the formulation to an optimal pH might improve its solubility in the GI tract.

Q2: Our in vitro assays show potent inhibition of VEGFR-2 by **NVP-ACC789**, but we are not observing the expected efficacy in vivo. Could this be a bioavailability issue?

A2: Yes, a discrepancy between in vitro potency and in vivo efficacy is a classic indicator of poor bioavailability. The effective concentration of **NVP-ACC789** may not be reaching the target tissues due to limited absorption. The IC50 values for **NVP-ACC789** against various VEGF receptors are in the nanomolar to low micromolar range, indicating high potency.[1][6][7] If the plasma concentrations are below these levels, the therapeutic effect will be diminished.

Troubleshooting Steps:

- **Pharmacokinetic (PK) Study:** Conduct a pilot PK study to determine the plasma concentration-time profile of **NVP-ACC789** after oral administration. This will provide crucial data on key parameters like C_{max} (maximum concentration), T_{max} (time to maximum concentration), and AUC (area under the curve).
- **Dose Escalation:** While maintaining safety, a dose escalation study can help determine if a higher dose can achieve the necessary therapeutic concentrations. However, be aware of potential solubility-limited absorption, where increasing the dose does not proportionally increase plasma concentration.[8]
- **Alternative Route of Administration:** To confirm that the lack of efficacy is due to poor oral bioavailability, administer **NVP-ACC789** via an intravenous (IV) route. This will ensure 100% bioavailability and provide a baseline for the required therapeutic plasma concentration.[4]

Q3: We are considering different formulation strategies to improve the bioavailability of **NVP-ACC789**. What are the key considerations?

A3: Choosing the right formulation strategy depends on the physicochemical properties of **NVP-ACC789** and the specific experimental context.

Formulation Strategy	Principle	Advantages
Particle Size Reduction	Increases surface area for dissolution.[2]	Simple, well-established techniques (milling).
Lipid-Based Systems	Drug is dissolved in lipids, enhancing absorption.[5]	Can bypass first-pass metabolism via lymphatic transport.[5]
Amorphous Solid Dispersions	Maintains the drug in a high-energy, solubilized state.[5]	Can significantly increase apparent solubility and dissolution rate.
Nanosuspensions	Sub-micron drug particles with increased surface area.[2]	Enhanced dissolution velocity and potential for altered biodistribution.

Experimental Protocols

Protocol 1: Preparation of a Micronized **NVP-ACC789** Suspension

- Objective: To increase the dissolution rate of **NVP-ACC789** by reducing its particle size.
- Materials: **NVP-ACC789**, mortar and pestle or a jet mill, vehicle (e.g., 0.5% methylcellulose in water), particle size analyzer.
- Procedure:
 1. Weigh the desired amount of **NVP-ACC789**.
 2. If using a mortar and pestle, grind the powder for a fixed duration (e.g., 15 minutes) to achieve micron-sized particles. For larger quantities and more uniform particle size, use a jet mill following the manufacturer's instructions.
 3. Characterize the particle size distribution of the micronized powder using a particle size analyzer to ensure it is within the desired range (e.g., 1-10 μm).
 4. Prepare the vehicle (e.g., 0.5% methylcellulose in sterile water).
 5. Gradually add the micronized **NVP-ACC789** to the vehicle while vortexing or stirring to form a homogenous suspension.
 6. Store the suspension at 2-8°C and ensure it is well-mixed before each administration.

Protocol 2: In Vivo Pharmacokinetic Study in Mice

- Objective: To determine the plasma concentration-time profile of **NVP-ACC789** following oral administration.
- Materials: **NVP-ACC789** formulation, appropriate mouse strain (e.g., BALB/c), oral gavage needles, blood collection supplies (e.g., heparinized capillaries), centrifuge, analytical instruments (LC-MS/MS).
- Procedure:
 1. Fast the mice overnight (with access to water) before dosing.

2. Administer the **NVP-ACC789** formulation via oral gavage at a specific dose (e.g., 50 mg/kg).
3. Collect blood samples (e.g., 20-30 μ L) from a consistent site (e.g., tail vein) at predetermined time points (e.g., 0, 0.5, 1, 2, 4, 8, and 24 hours post-dose).
4. Immediately place the blood samples into heparinized tubes and centrifuge to separate the plasma.
5. Store the plasma samples at -80°C until analysis.
6. Quantify the concentration of **NVP-ACC789** in the plasma samples using a validated LC-MS/MS method.
7. Plot the plasma concentration versus time to determine key PK parameters.

Visualizations

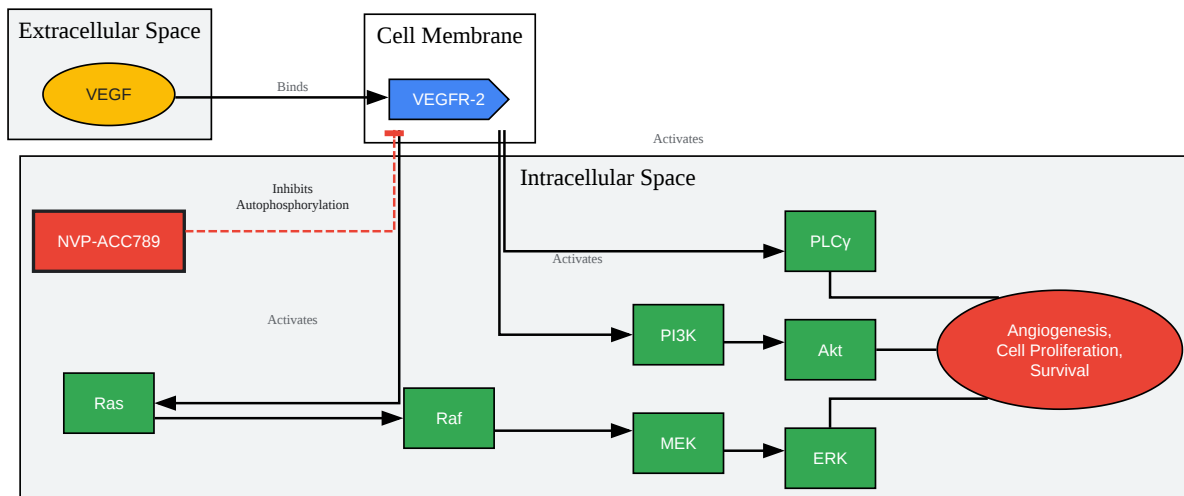

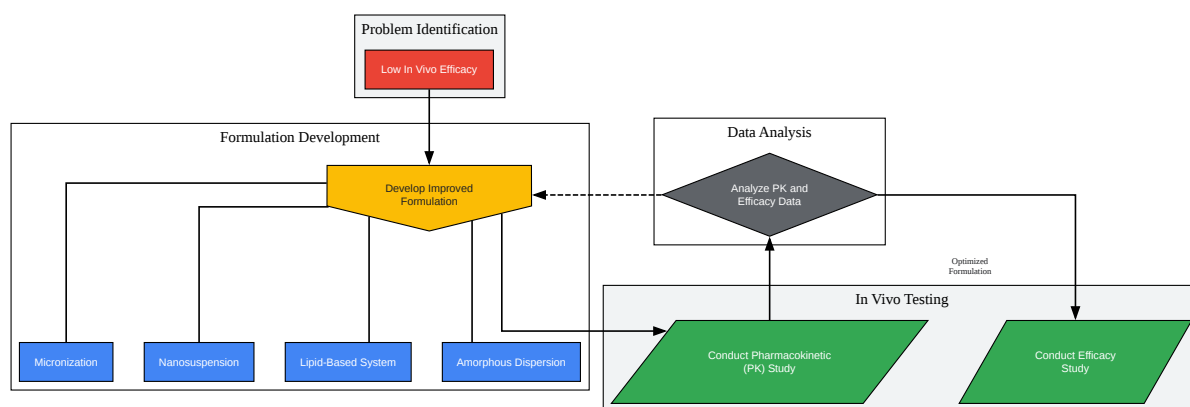

[Click to download full resolution via product page](#)

Need Custom Synthesis?

BenchChem offers custom synthesis for rare earth carbides and specific isotopic labeling.

Email: info@benchchem.com or [Request Quote Online](#).

References

- 1. caymanchem.com [caymanchem.com]
- 2. Bioavailability Enhancement Techniques for Poorly Aqueous Soluble Drugs and Therapeutics - PMC [pmc.ncbi.nlm.nih.gov]
- 3. Methods of enhancing bioavailability of drugs | PPTX [slideshare.net]

- [4. researchgate.net \[researchgate.net\]](#)
- [5. upm-inc.com \[upm-inc.com\]](#)
- [6. abmole.com \[abmole.com\]](#)
- [7. NVP-ACC789 | CAS#:300842-64-2 | Chemsrvc \[chemsrc.com\]](#)
- [8. sygnaturediscovery.com \[sygnaturediscovery.com\]](#)
- To cite this document: BenchChem. [Technical Support Center: NVP-ACC789 In Vivo Bioavailability]. BenchChem, [2026]. [Online PDF]. Available at: [\[https://www.benchchem.com/product/b1666487/docs#technical-support-center-nvp-acc789-in-vivo-bioavailability\]](https://www.benchchem.com/product/b1666487/docs#technical-support-center-nvp-acc789-in-vivo-bioavailability)

Disclaimer & Data Validity:

The information provided in this document is for Research Use Only (RUO) and is strictly not intended for diagnostic or therapeutic procedures. While BenchChem strives to provide accurate protocols, we make no warranties, express or implied, regarding the fitness of this product for every specific experimental setup.

Technical Support: The protocols provided are for reference purposes. Unsure if this reagent suits your experiment?

Need Industrial/Bulk Grade? [Request Custom Synthesis Quote](#)

BenchChem

Our mission is to be the trusted global source of essential and advanced chemicals, empowering scientists and researchers to drive progress in science and industry.

Contact

Address: 3281 E Guasti Rd

Ontario, CA 91761, United States

Phone: (601) 213-4426

Email: info@benchchem.com

Contact our Ph.D. Support Team for a compatibility check