

Application Notes and Protocols for Solution Stability and Storage of D942

Author: BenchChem Technical Support Team. **Date:** December 2025

Compound of Interest

Compound Name: D942

Cat. No.: B1666018

[Get Quote](#)

For Researchers, Scientists, and Drug Development Professionals

These application notes provide a comprehensive overview of the solution stability of the investigational compound **D942**. The included protocols and data are intended to guide researchers in the proper handling, storage, and use of **D942** solutions to ensure experimental accuracy and reproducibility.

Introduction

D942 is a novel therapeutic agent currently under investigation. Understanding its stability in solution is critical for the reliability of preclinical and clinical studies. This document outlines the recommended storage conditions and provides detailed protocols for stability assessment.

Physicochemical Properties

A summary of the key physicochemical properties of **D942** is essential for understanding its behavior in solution.

Property	Value
Chemical Name	[Insert Chemical Name]
Molecular Formula	[Insert Molecular Formula]
Molecular Weight	[Insert Molecular Weight] g/mol
pKa	[Insert pKa value(s)]
LogP	[Insert LogP value]
Aqueous Solubility	[Insert solubility data] mg/mL at pH [X]

Solution Stability of D942

Forced degradation studies were conducted to determine the intrinsic stability of **D942** and to identify potential degradation pathways. These studies exposed **D942** solutions to various stress conditions, including acid, base, oxidation, heat, and light.

pH-Dependent Stability

The stability of **D942** was evaluated across a range of pH values to identify the optimal pH for solution stability. The results indicate that **D942** is most stable at a neutral pH.^{[1][2]}

Table 1: Stability of **D942** Solution (0.1 mg/mL) at Different pH Values after 24 hours at 25°C

pH	% Recovery of D942	Degradation Products Observed
2.0	85.2%	DP-1, DP-2
4.0	95.8%	DP-1
7.0	99.5%	None Detected
9.0	92.1%	DP-3
12.0	78.4%	DP-3, DP-4

Temperature Stability

The effect of temperature on the stability of **D942** solutions was assessed to establish appropriate storage and handling temperatures.

Table 2: Stability of **D942** Solution (0.1 mg/mL, pH 7.0) at Different Temperatures

Temperature	Storage Duration	% Recovery of D942
40°C	7 days	90.3%
25°C	30 days	98.1%
4°C	90 days	99.2%
-20°C	180 days	99.8%

Photostability

Photostability testing was conducted to determine the susceptibility of **D942** to degradation upon exposure to light.

Table 3: Photostability of **D942** Solution (0.1 mg/mL, pH 7.0)

Light Source	Exposure Duration	% Recovery of D942
Cool White Fluorescent	24 hours	99.1%
Near UV (365 nm)	24 hours	92.5%

Oxidative Stability

The stability of **D942** in the presence of an oxidizing agent was evaluated.

Table 4: Oxidative Stability of **D942** Solution (0.1 mg/mL, pH 7.0)

Oxidizing Agent	Concentration	Exposure Time	% Recovery of D942
Hydrogen Peroxide	3%	8 hours	88.7%

Recommended Storage Conditions

Based on the stability data, the following storage conditions are recommended for **D942** solutions:

- Short-term (≤ 72 hours): Store at 2-8°C, protected from light.
- Long-term (> 72 hours): Store at -20°C or colder in airtight containers, protected from light.
- Working Solutions: Prepare fresh daily. If short-term storage is necessary, keep on ice and protect from light.

Experimental Protocols

The following protocols describe the methodologies used to generate the stability data presented in this document.

Protocol: Preparation of D942 Stock Solution

- Objective: To prepare a 10 mg/mL stock solution of **D942** in a suitable solvent.
- Materials:
 - **D942** powder
 - Dimethyl Sulfoxide (DMSO), ACS grade
 - Sterile, amber microcentrifuge tubes
 - Calibrated analytical balance and weigh paper
 - Vortex mixer
- Procedure:
 1. Tare the analytical balance with a clean piece of weigh paper.
 2. Carefully weigh 10 mg of **D942** powder.

3. Transfer the powder to a sterile, amber microcentrifuge tube.
4. Add 1.0 mL of DMSO to the tube.
5. Vortex the solution until the **D942** is completely dissolved.
6. Aliquot into smaller volumes for single-use to avoid repeated freeze-thaw cycles.
7. Store aliquots at -20°C, protected from light.

Protocol: pH Stability Assessment

- Objective: To determine the stability of **D942** across a range of pH values.
- Materials:
 - **D942** stock solution (10 mg/mL in DMSO)
 - Buffer solutions (pH 2, 4, 7, 9, 12)
 - HPLC system with UV detector
 - HPLC column suitable for **D942** analysis
 - Mobile phase
- Procedure:
 1. Prepare 0.1 mg/mL solutions of **D942** in each buffer.
 2. Incubate the solutions at 25°C.
 3. At specified time points (e.g., 0, 4, 8, 24 hours), withdraw an aliquot from each solution.
 4. Immediately analyze the aliquots by a validated stability-indicating HPLC method.
 5. Calculate the percentage of **D942** remaining relative to the initial time point.

Protocol: Forced Degradation Study (Oxidation)

- Objective: To assess the stability of **D942** under oxidative stress.
- Materials:
 - **D942** stock solution (10 mg/mL in DMSO)
 - Phosphate Buffered Saline (PBS), pH 7.4
 - 30% Hydrogen Peroxide (H₂O₂) solution
 - HPLC system
- Procedure:
 1. Prepare a 0.1 mg/mL solution of **D942** in PBS.
 2. Add H₂O₂ to a final concentration of 3%.
 3. Incubate the solution at room temperature, protected from light.
 4. At specified time points (e.g., 0, 2, 4, 8 hours), withdraw an aliquot.
 5. Analyze the samples by HPLC to determine the remaining **D942** and identify major degradation products.

Visualizations

D942 Degradation Pathway

The following diagram illustrates the proposed degradation pathways of **D942** under stress conditions.

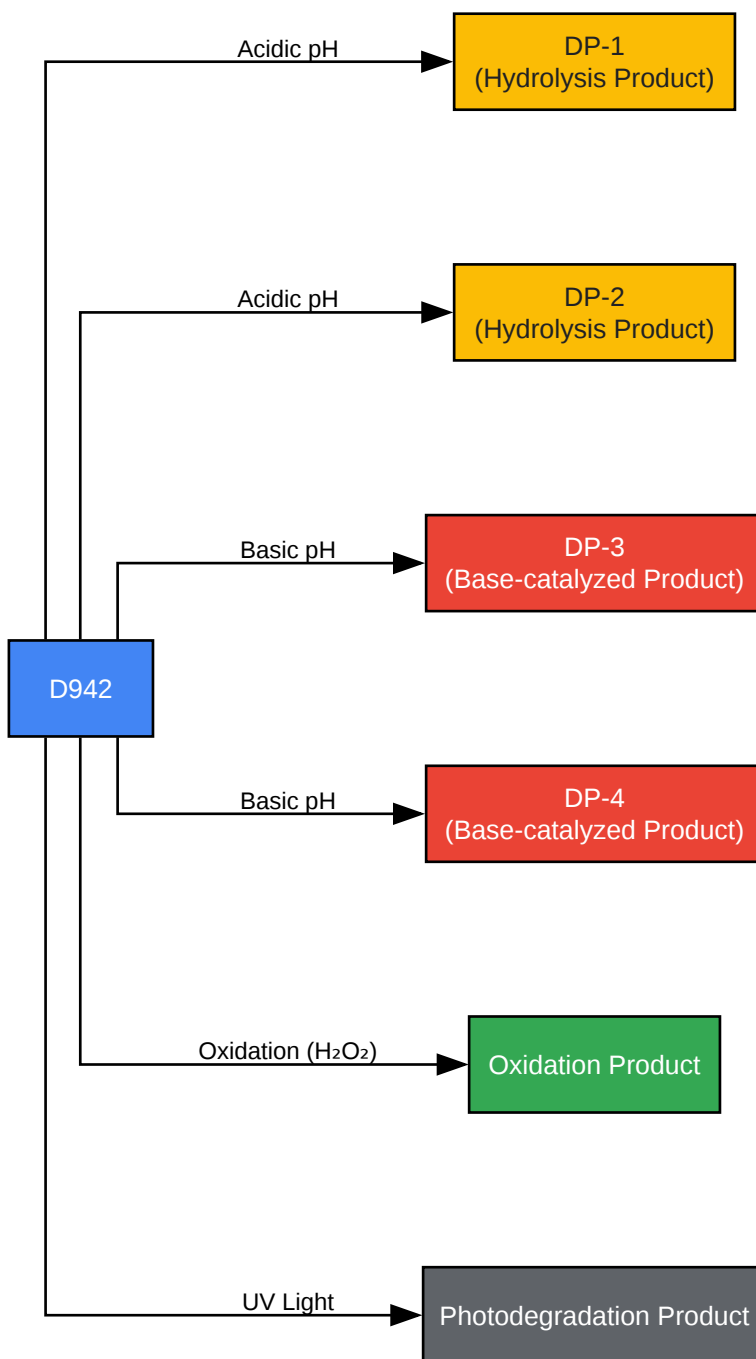

[Click to download full resolution via product page](#)

Caption: Proposed degradation pathways of **D942** under various stress conditions.

Experimental Workflow for Stability Testing

This workflow outlines the general procedure for assessing the solution stability of **D942**.

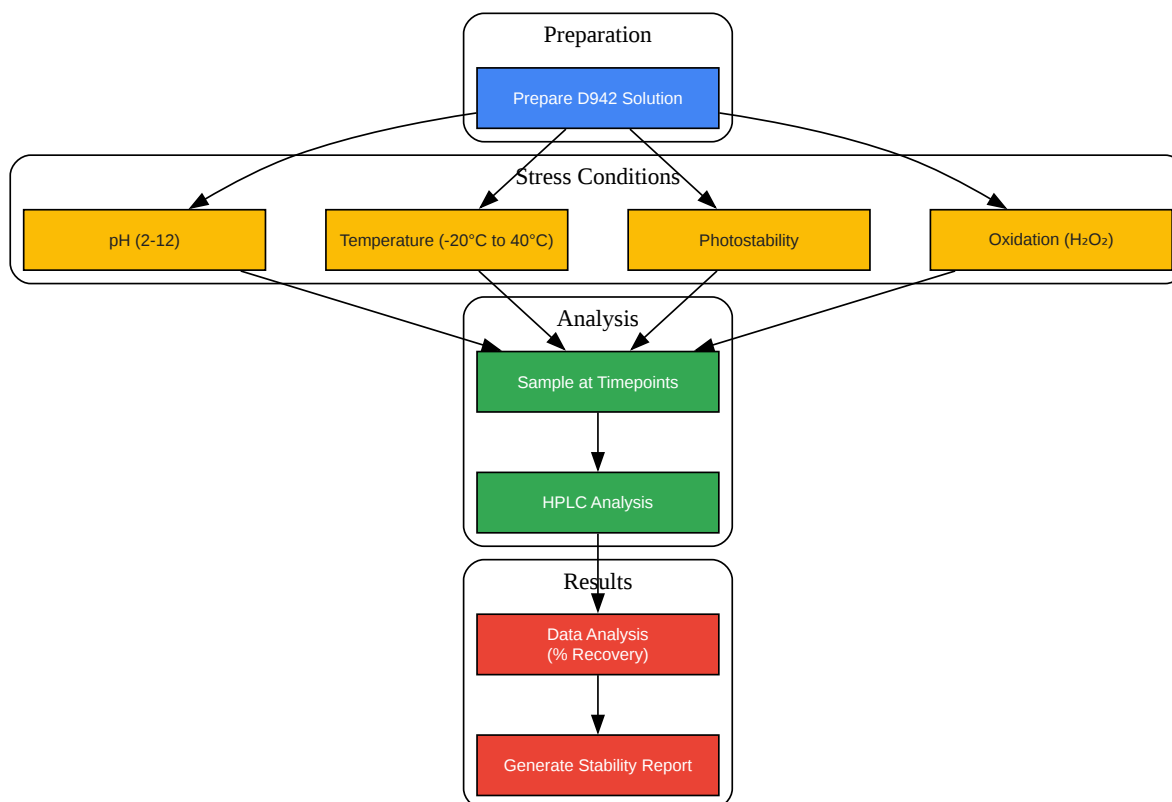

[Click to download full resolution via product page](#)

Caption: General experimental workflow for **D942** solution stability testing.

Need Custom Synthesis?

BenchChem offers custom synthesis for rare earth carbides and specific isotopic labeling.

Email: info@benchchem.com or [Request Quote Online](#).

References

- 1. Solution stability of factor Xa inhibitors as a function of pH - PubMed [pubmed.ncbi.nlm.nih.gov]
- 2. Stability study on an anti-cancer drug 4-(3,5-bis(2-chlorobenzylidene)-4-oxo-piperidine-1-yl)-4-oxo-2-butenoic acid (CLEFMA) using a stability-indicating HPLC method - PMC [pmc.ncbi.nlm.nih.gov]
- To cite this document: BenchChem. [Application Notes and Protocols for Solution Stability and Storage of D942]. BenchChem, [2025]. [Online PDF]. Available at: [https://www.benchchem.com/product/b1666018#d942-solution-stability-and-storage-conditions]

Disclaimer & Data Validity:

The information provided in this document is for Research Use Only (RUO) and is strictly not intended for diagnostic or therapeutic procedures. While BenchChem strives to provide accurate protocols, we make no warranties, express or implied, regarding the fitness of this product for every specific experimental setup.

Technical Support: The protocols provided are for reference purposes. Unsure if this reagent suits your experiment? [[Contact our Ph.D. Support Team for a compatibility check](#)]

Need Industrial/Bulk Grade? [Request Custom Synthesis Quote](#)

BenchChem

Our mission is to be the trusted global source of essential and advanced chemicals, empowering scientists and researchers to drive progress in science and industry.

Contact

Address: 3281 E Guasti Rd
Ontario, CA 91761, United States
Phone: (601) 213-4426
Email: info@benchchem.com