

Application Notes: Azido-PEG3-azide for Click Chemistry Crosslinking

Author: BenchChem Technical Support Team. **Date:** April 2026

Compound of Interest

Compound Name: Azido-PEG3-azide

CAS No.: 101187-39-7

Cat. No.: B1666261

[Get Quote](#)

Introduction

Azido-PEG3-azide is a hydrophilic, bifunctional crosslinker used in click chemistry.[1][2] It consists of a short polyethylene glycol (PEG) spacer flanked by two terminal azide (N_3) groups. This structure allows for the covalent linkage of two alkyne-containing molecules through either a Copper-Catalyzed Azide-Alkyne Cycloaddition (CuAAC) or a Strain-Promoted Azide-Alkyne Cycloaddition (SPAAC) reaction.[3][4] The PEG3 spacer enhances aqueous solubility, reduces aggregation of conjugates, and provides a flexible linkage between the two conjugated molecules.[2][5]

Key Features & Applications

- **Homobifunctional Crosslinking:** The presence of two azide groups enables the crosslinking of two molecules that have been functionalized with terminal or strained alkynes.
- **Enhanced Solubility:** The hydrophilic PEG linker improves the solubility of the crosslinker and the resulting conjugate in aqueous buffers, which is highly beneficial for biological applications.[2][6]

- **Biocompatibility:** In its copper-free (SPAAC) application, the reaction is bioorthogonal and can be performed in living systems without the cytotoxicity associated with copper catalysts. [5][7]
- **Versatility:** **Azido-PEG3-azide** is a versatile tool for various applications in research and drug development, including:
 - **Antibody-Drug Conjugate (ADC) Development:** Crosslinking targeting antibodies to cytotoxic payloads. [2][8]
 - **PROTAC Synthesis:** Linking a target protein-binding ligand to an E3 ubiquitin ligase ligand. [5]
 - **Biomolecule Labeling and Imaging:** Conjugating fluorophores or other imaging agents to biomolecules. [5]
 - **Hydrogel Formation:** Creating crosslinked polymer networks for biomaterials.
 - **Surface Modification:** Immobilizing biomolecules onto surfaces for diagnostics. [5]

Mechanism of Action: Click Chemistry

Click chemistry describes a class of reactions that are rapid, high-yielding, and highly specific. [4][9] **Azido-PEG3-azide** participates in two main types of click reactions:

- **Copper-Catalyzed Azide-Alkyne Cycloaddition (CuAAC):** This reaction involves the use of a Copper(I) catalyst to join an azide with a terminal alkyne, forming a stable 1,4-disubstituted triazole ring. [4][10] The reaction is robust but requires a copper catalyst, which can be toxic to living cells. To mitigate this, a reducing agent like sodium ascorbate is used to maintain copper in its active Cu(I) state, and a stabilizing ligand (e.g., THPTA, TBTA) is often included to protect biomolecules and enhance reaction efficiency. [11][12]
- **Strain-Promoted Azide-Alkyne Cycloaddition (SPAAC):** This is a copper-free click reaction that utilizes a strained cyclooctyne, such as dibenzocyclooctyne (DBCO) or bicyclo[6.1.0]nonyne (BCN). [5][7] The ring strain of the alkyne provides the energy needed to drive the reaction forward without a catalyst, making it ideal for applications in living systems. [7][13]

Visualized Workflows and Mechanisms

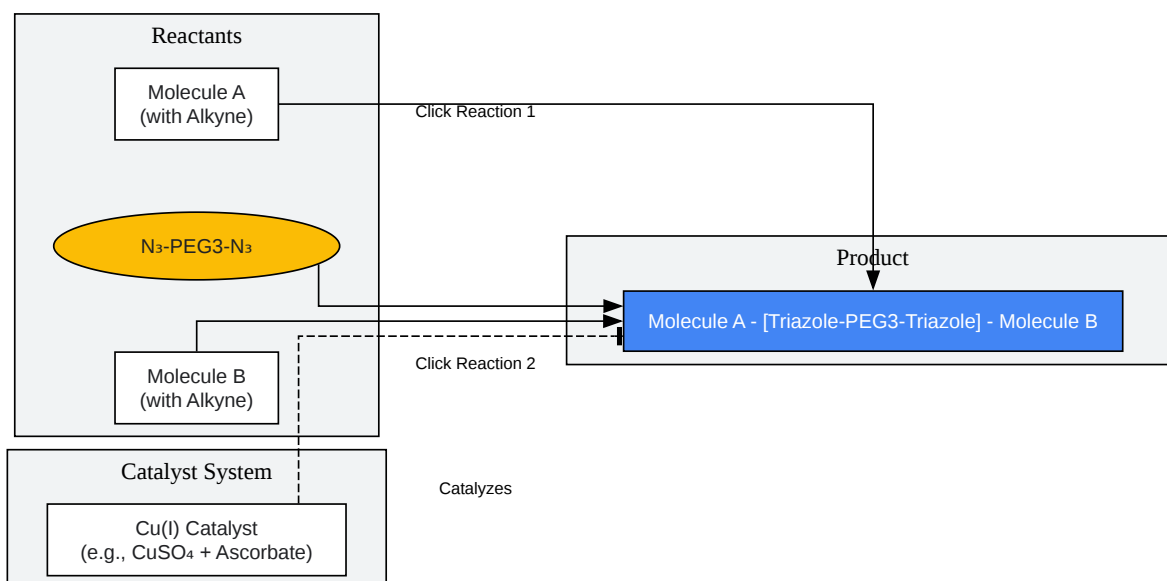

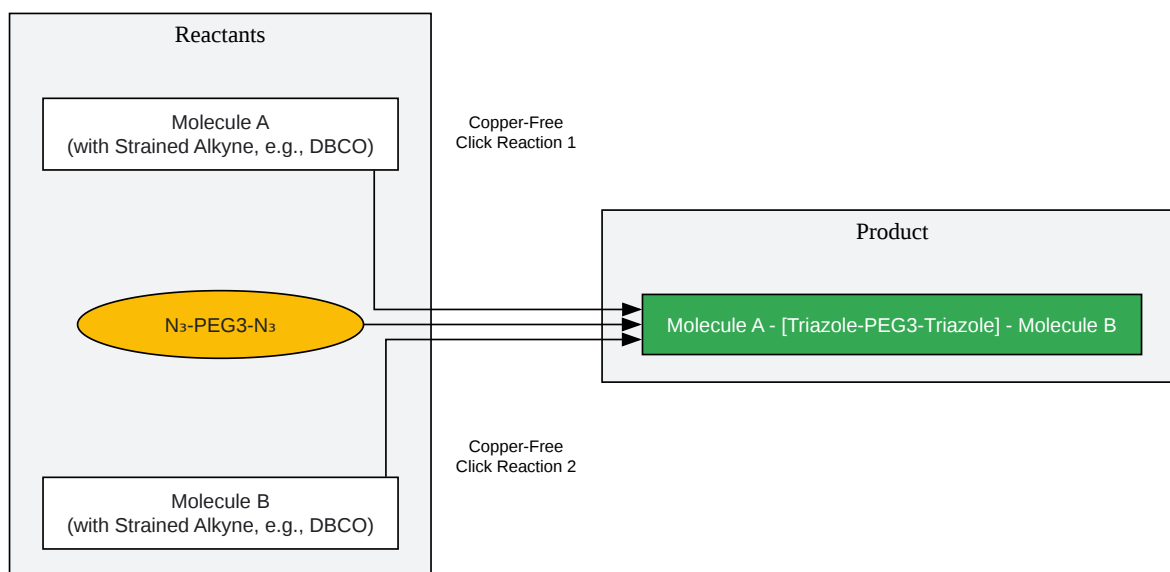

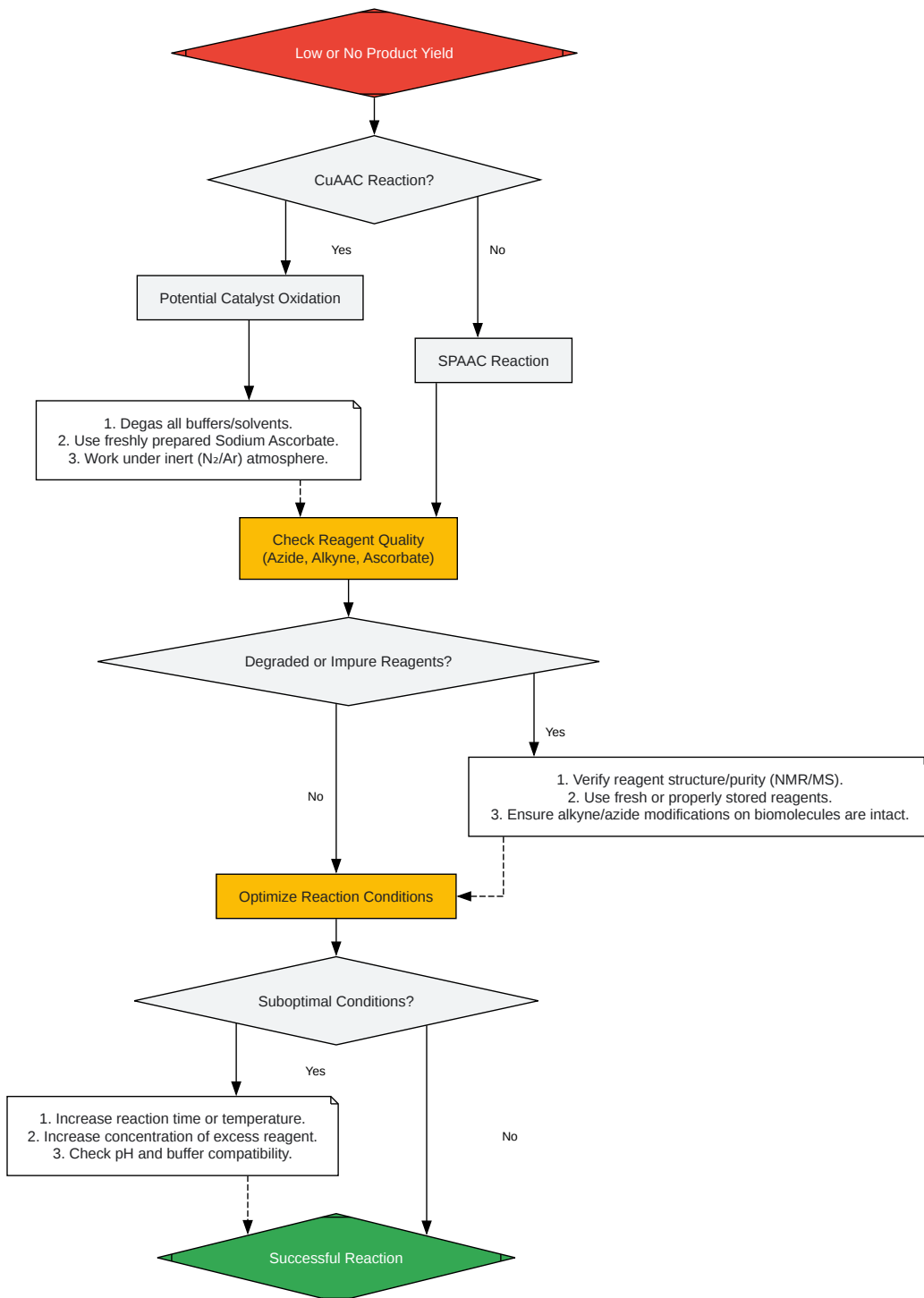

[Click to download full resolution via product page](#)

Need Custom Synthesis?

BenchChem offers custom synthesis for rare earth carbides and specific isotopic labeling.

Email: info@benchchem.com or [Request Quote Online](#).

References

- [1. Azide PEG, Azide linker for Click Chemistry Reactions | AxisPharm \[axispharm.com\]](#)
- [2. lumiprobe.com \[lumiprobe.com\]](#)
- [3. Click Chemistry Reagents/Tools, Azide, Alkyne, DBCO, BCN PEG - Biochempeg \[biochempeg.com\]](#)
- [4. Click Chemistry \[organic-chemistry.org\]](#)
- [5. benchchem.com \[benchchem.com\]](#)
- [6. broadpharm.com \[broadpharm.com\]](#)
- [7. bioconjugation.bocsci.com \[bioconjugation.bocsci.com\]](#)
- [8. axispharm.com \[axispharm.com\]](#)
- [9. chemie-brunschwig.ch \[chemie-brunschwig.ch\]](#)
- [10. bioconjugation.bocsci.com \[bioconjugation.bocsci.com\]](#)
- [11. jenabioscience.com \[jenabioscience.com\]](#)
- [12. interchim.fr \[interchim.fr\]](#)
- [13. Strain-Promoted Azide-Alkyne Cycloaddition \[manu56.magtech.com.cn\]](#)
- To cite this document: BenchChem. [Application Notes: Azido-PEG3-azide for Click Chemistry Crosslinking]. BenchChem, [2026]. [Online PDF]. Available at: [\[https://www.benchchem.com/product/b1666261/docs#application-notes-azido-peg3-azide-for-click-chemistry-crosslinking\]](https://www.benchchem.com/product/b1666261/docs#application-notes-azido-peg3-azide-for-click-chemistry-crosslinking)

Disclaimer & Data Validity:

The information provided in this document is for Research Use Only (RUO) and is strictly not intended for diagnostic or therapeutic procedures. While BenchChem strives to provide accurate protocols, we make no warranties, express or implied, regarding the fitness of this product for every specific experimental setup.

Technical Support: The protocols provided are for reference purposes. Unsure if this reagent suits your experiment?

Need Industrial/Bulk Grade? [Request Custom Synthesis Quote](#)

BenchChem

Our mission is to be the trusted global source of essential and advanced chemicals, empowering scientists and researchers to drive progress in science and industry.

Contact

Address: 3281 E Guasti Rd
Ontario, CA 91761, United States
Phone: (601) 213-4426
Email: info@benchchem.com

[Contact our Ph.D. Support Team for a compatibility check](#)