

Technical Support Center: Minimizing Off-Target Activity of ATC0175

Author: BenchChem Technical Support Team. **Date:** April 2026

Compound of Interest

Compound Name:	ATC0175
CAS No.:	510733-97-8
Cat. No.:	B1665810

[Get Quote](#)

This technical support center provides researchers, scientists, and drug development professionals with guidance on minimizing the off-target activity of **ATC0175**, a selective antagonist of the melanin-concentrating hormone receptor 1 (MCH1). This guide offers troubleshooting advice, frequently asked questions (FAQs), detailed experimental protocols, and data presentation to facilitate the design and interpretation of experiments involving **ATC0175**.

Frequently Asked Questions (FAQs)

Q1: What is **ATC0175** and what are its known off-targets?

ATC0175 is a selective, non-peptide antagonist of the melanin-concentrating hormone receptor 1 (MCH1). While it is potent and selective for MCH1, it also displays affinity for the serotonin receptors 5-HT1A and 5-HT2B, which are considered its primary off-targets.

Q2: Why is it crucial to minimize the off-target activity of **ATC0175** in my experiments?

Minimizing off-target effects is critical for the accurate interpretation of experimental results. Off-target binding can lead to misleading conclusions, where an observed phenotype is incorrectly

attributed to the inhibition of MCH1 when it is, in fact, a consequence of engaging with 5-HT1A or 5-HT2B receptors. This can result in wasted resources and flawed conclusions about the biological role of MCH1.

Q3: What are the initial signs of potential off-target effects in my experiments with **ATC0175**?

Potential off-target effects of **ATC0175** may manifest as:

- Inconsistent results: Discrepancies between your findings and previously published data on MCH1 inhibition.
- Unexpected phenotypes: Observing cellular or physiological effects that are not consistent with the known signaling pathways of MCH1.
- Dose-response discrepancies: A lack of a clear dose-response relationship, or observing effects at concentrations significantly different from the reported IC50 for MCH1.

Q4: What are the primary strategies to minimize **ATC0175** off-target activity?

To minimize off-target effects, a multi-faceted approach is recommended:

- Use the Lowest Effective Concentration: Titrate **ATC0175** to the lowest concentration that elicits the desired on-target effect to reduce the likelihood of engaging off-targets.
- Employ Orthogonal Validation: Use structurally and mechanistically different MCH1 antagonists to confirm that the observed phenotype is not specific to the chemical scaffold of **ATC0175**.
- Utilize Genetic Validation: Employ techniques like CRISPR/Cas9 or siRNA to knock down the MCH1 receptor. If the phenotype persists in the absence of the primary target, it is likely due to an off-target effect.
- Perform Target Engagement Assays: Directly measure the binding of **ATC0175** to MCH1 and its off-targets in your experimental system using techniques like the Cellular Thermal Shift Assay (CETSA).

Troubleshooting Guide

Issue	Possible Cause	Troubleshooting Steps	Expected Outcome
Observed phenotype is inconsistent with known MCH1 function.	Off-target engagement of 5-HT1A or 5-HT2B receptors.	<ol style="list-style-type: none"> 1. Perform a dose-response experiment to determine if the effect is observed at concentrations consistent with ATC0175's affinity for its off-targets. 2. Use a selective 5-HT1A or 5-HT2B antagonist in conjunction with ATC0175 to see if the phenotype is rescued. 3. Genetically knock down MCH1 and repeat the experiment. 	<ol style="list-style-type: none"> 1. A clearer understanding of which receptor is responsible for the observed phenotype. 2. Confirmation of on-target versus off-target effects.
High cellular toxicity observed at effective concentrations of ATC0175.	Off-target effects leading to cellular stress or apoptosis.	<ol style="list-style-type: none"> 1. Lower the concentration of ATC0175 to the minimal effective dose for MCH1 inhibition. 2. Test the toxicity of ATC0175 in a cell line that does not express MCH1 but does express the off-target receptors. 	Identification of a therapeutic window where on-target effects are maximized and off-target toxicity is minimized.
Difficulty replicating results from other studies using ATC0175.	Variations in experimental conditions affecting inhibitor potency and selectivity.	<ol style="list-style-type: none"> 1. Carefully review and standardize experimental protocols, including cell lines, passage numbers, and media components. 2. 	Improved reproducibility and confidence in experimental findings.

Confirm the identity and purity of the ATC0175 compound.

3. Perform a target engagement assay to confirm ATC0175 is binding to MCH1 in your system.

Quantitative Data Summary

The following table summarizes the inhibitory potency (IC₅₀) of **ATC0175** for its primary target and known off-targets. Lower IC₅₀ values indicate higher potency.

Target	IC ₅₀ (nM)	Receptor Type
MCH1	13.5	G-protein coupled receptor (GPCR)
5-HT2B	9.66	G-protein coupled receptor (GPCR)
5-HT1A	16.9	G-protein coupled receptor (GPCR)
MCH2	>10,000	G-protein coupled receptor (GPCR)

Data sourced from Tocris Bioscience.

Experimental Protocols

Radioligand Binding Assay for MCH1 Receptor

Objective: To determine the binding affinity of **ATC0175** for the MCH1 receptor by measuring its ability to displace a radiolabeled ligand.

Methodology:

- Membrane Preparation:
 - Homogenize cells or tissues expressing the MCH1 receptor in a cold lysis buffer (e.g., 50 mM Tris-HCl, 5 mM MgCl₂, pH 7.4) containing protease inhibitors.
 - Centrifuge the homogenate at low speed to remove cellular debris.
 - Centrifuge the supernatant at high speed (e.g., 40,000 x g) to pellet the cell membranes.
 - Wash the membrane pellet with fresh buffer and resuspend in an appropriate assay buffer.
 - Determine the protein concentration of the membrane preparation.
- Binding Assay:
 - In a 96-well plate, combine the membrane preparation, a constant concentration of a suitable MCH1 radioligand (e.g., [125I]-MCH), and varying concentrations of **ATC0175**.
 - To determine non-specific binding, include wells with the membrane preparation, radioligand, and a high concentration of a non-radiolabeled MCH1 agonist or antagonist.
 - Incubate the plate at room temperature for a sufficient time to reach binding equilibrium (e.g., 60-90 minutes).
- Separation and Detection:
 - Rapidly filter the contents of each well through a glass fiber filtermat using a cell harvester to separate bound from free radioligand.
 - Wash the filters several times with ice-cold wash buffer.
 - Measure the radioactivity retained on the filters using a scintillation counter.
- Data Analysis:
 - Subtract the non-specific binding from the total binding to obtain specific binding at each concentration of **ATC0175**.

- Plot the specific binding as a function of the **ATC0175** concentration and fit the data to a one-site competition model to determine the IC50 value.

Cellular Thermal Shift Assay (CETSA)

Objective: To confirm the engagement of **ATC0175** with its target protein(s) in intact cells.

Methodology:

- Cell Treatment:
 - Culture cells to an appropriate confluency.
 - Treat the cells with either vehicle control or varying concentrations of **ATC0175** for a specified duration (e.g., 1-2 hours) at 37°C.
- Thermal Challenge:
 - Harvest and wash the cells, then resuspend them in a suitable buffer (e.g., PBS with protease inhibitors).
 - Aliquot the cell suspension into PCR tubes or a 96-well PCR plate.
 - Heat the samples across a range of temperatures (e.g., 40-70°C) for a short duration (e.g., 3-5 minutes) using a thermocycler.
- Cell Lysis and Protein Separation:
 - Lyse the cells by freeze-thaw cycles or by adding a lysis buffer.
 - Centrifuge the lysates at high speed to pellet the aggregated, denatured proteins.
- Protein Detection and Analysis:
 - Carefully collect the supernatant containing the soluble proteins.
 - Analyze the amount of the target protein (MCH1, 5-HT1A, or 5-HT2B) in the soluble fraction using Western blotting or another sensitive protein detection method.

- Plot the amount of soluble target protein as a function of temperature for both vehicle- and **ATC0175**-treated samples. A shift in the melting curve to a higher temperature in the presence of **ATC0175** indicates target engagement.

Visualizations

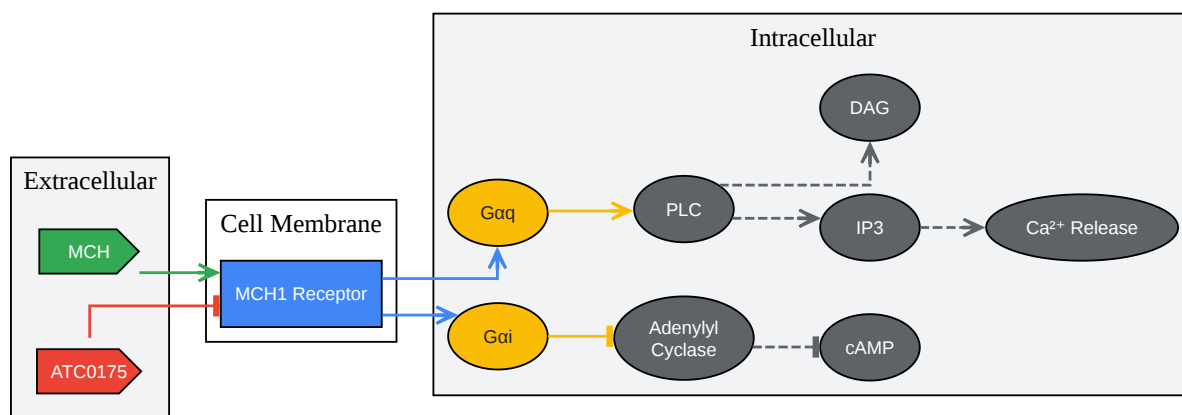

[Click to download full resolution via product page](#)

Caption: MCH1 Receptor Signaling and **ATC0175** Inhibition.

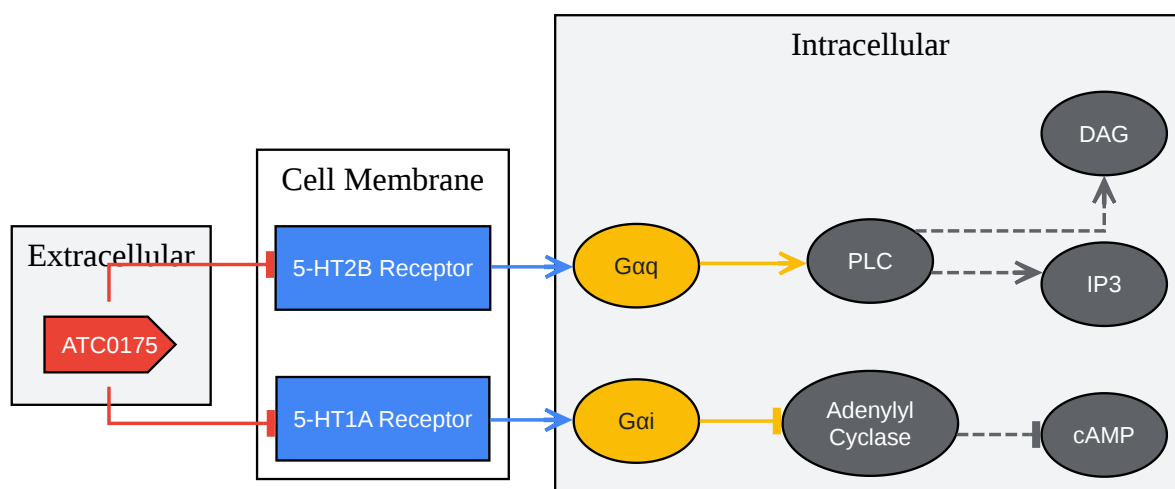

[Click to download full resolution via product page](#)

Caption: Off-target signaling of **ATC0175** via 5-HT receptors.

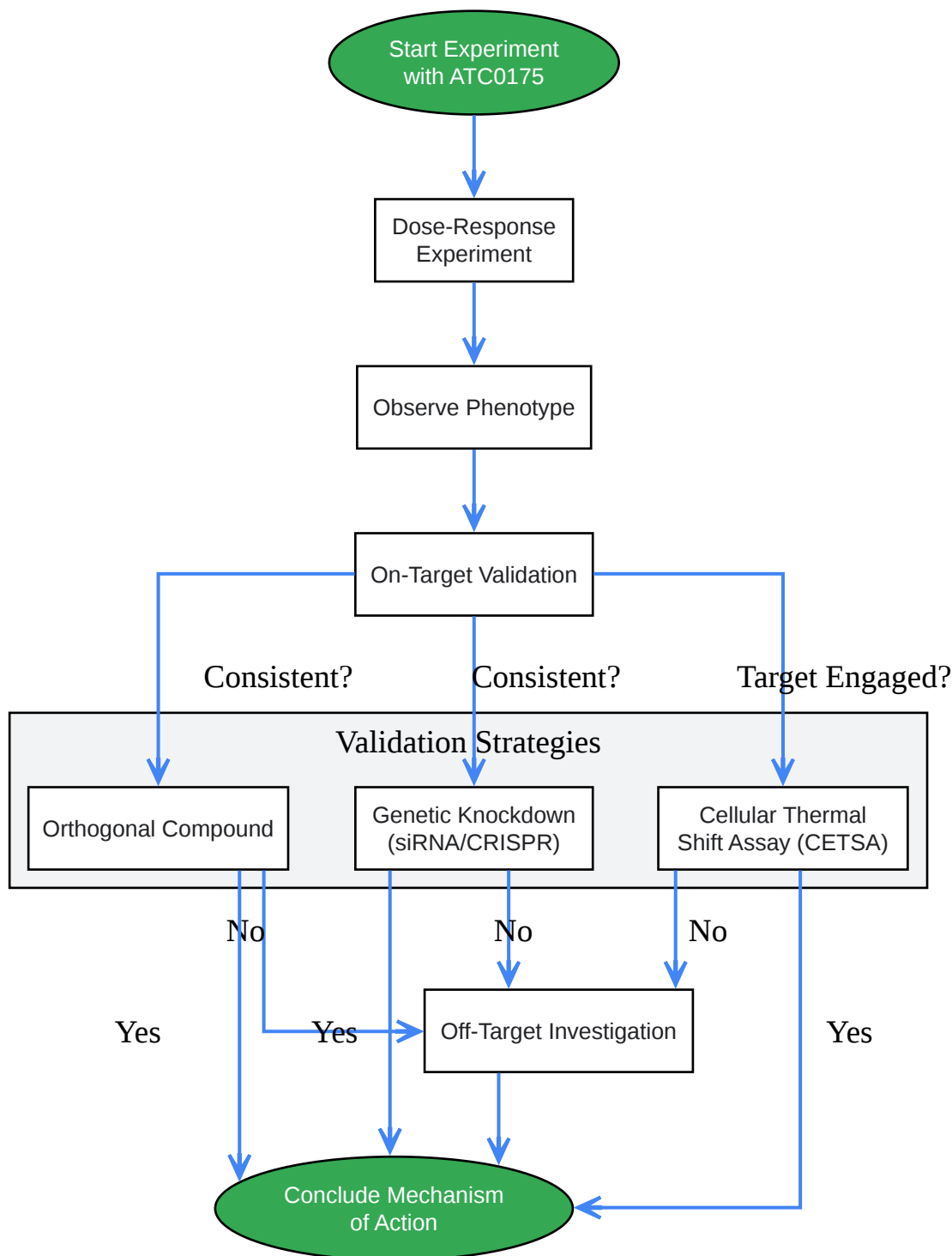

[Click to download full resolution via product page](#)

Caption: Workflow for validating **ATC0175** on-target effects.

- To cite this document: BenchChem. [Technical Support Center: Minimizing Off-Target Activity of ATC0175]. BenchChem, [2026]. [Online PDF]. Available at: [<https://www.benchchem.com/product/b1665810/docs#technical-support-center-minimizing-off-target-activity-of-atc0175>]

Disclaimer & Data Validity:

The information provided in this document is for Research Use Only (RUO) and is strictly not intended for diagnostic or therapeutic procedures. While BenchChem strives to provide accurate protocols, we make no warranties, express or implied, regarding the fitness of this product for every specific experimental setup.

Technical Support: The protocols provided are for reference purposes. Unsure if this reagent suits your experiment?

Need Industrial/Bulk Grade? [Request Custom Synthesis Quote](#)

BenchChem

Our mission is to be the trusted global source of essential and advanced chemicals, empowering scientists and researchers to drive progress in science and industry.

Contact

Address: 3281 E Guasti Rd
Ontario, CA 91761, United States
Phone: (601) 213-4426
Email: info@benchchem.com

[Contact our Ph.D. Support Team for a compatibility check](#)