

How to address AR-C117977 solubility and stability issues.

Author: BenchChem Technical Support Team. **Date:** December 2025

Compound of Interest

Compound Name: AR-C117977

Cat. No.: B1665596

[Get Quote](#)

Technical Support Center: AR-C117977

This technical support center provides troubleshooting guides and frequently asked questions (FAQs) to address common solubility and stability challenges encountered by researchers, scientists, and drug development professionals working with **AR-C117977**.

Frequently Asked Questions (FAQs)

Q1: What is **AR-C117977** and what is its mechanism of action?

AR-C117977 is a potent and specific inhibitor of the Monocarboxylate Transporter 1 (MCT1). MCT1 is a transmembrane protein responsible for the transport of monocarboxylates, such as lactate and pyruvate, across the cell membrane. By inhibiting MCT1, **AR-C117977** disrupts the metabolic symbiosis in tumors, where glycolytic cancer cells export lactate that is then taken up and used as an oxidative fuel by other cancer cells. This disruption of lactate flux can lead to intracellular acidification and cell death in cancer cells that rely on this metabolic pathway.

Q2: I am having trouble dissolving **AR-C117977**. What solvents are recommended?

AR-C117977 is known to have limited solubility in aqueous solutions. For in vitro experiments, it is recommended to prepare a stock solution in an organic solvent such as Dimethyl Sulfoxide (DMSO). While specific quantitative solubility data for **AR-C117977** is not widely published, similar small molecule inhibitors are often soluble in DMSO at concentrations of 10-50 mM. For final experimental concentrations, the DMSO stock solution should be diluted in the aqueous

medium, ensuring the final DMSO concentration is kept low (typically <0.5%) to avoid solvent-induced cellular toxicity.

Q3: My **AR-C117977** solution appears cloudy or shows precipitation after dilution in my cell culture medium. What should I do?

This is a common issue when diluting a DMSO stock solution of a hydrophobic compound into an aqueous medium. Here are some troubleshooting steps:

- Decrease the final concentration: The concentration of **AR-C117977** in your final medium may be above its solubility limit. Try a lower final concentration.
- Increase the DMSO concentration (with caution): A slightly higher final DMSO concentration (e.g., up to 1%) might improve solubility, but it is crucial to run a vehicle control to ensure the solvent is not affecting your experimental results.
- Use a pre-warmed medium: Adding the DMSO stock to a pre-warmed (37°C) medium can sometimes improve solubility.
- Vortex immediately after dilution: Vigorous mixing immediately after adding the stock solution to the medium can help prevent precipitation.
- Consider using a formulation with excipients: For in vivo studies, specialized formulations containing solubilizing agents may be necessary.

Q4: How should I store **AR-C117977** powder and its stock solutions to ensure stability?

- Powder: The solid form of **AR-C117977** should be stored at room temperature, as recommended by suppliers.^[1] Keep the container tightly sealed to protect it from moisture.
- Stock Solutions: DMSO stock solutions should be stored at -20°C or -80°C for long-term stability. Aliquoting the stock solution into smaller, single-use volumes is highly recommended to avoid repeated freeze-thaw cycles, which can lead to degradation.

Troubleshooting Guides

Problem 1: Inconsistent experimental results with AR-C117977.

Inconsistent results can often be traced back to issues with the compound's solubility and stability.

Potential Cause 1: Degradation of **AR-C117977** in stock solution.

- Troubleshooting:
 - Prepare a fresh stock solution of **AR-C117977**.
 - Aliquot the new stock solution into single-use vials to minimize freeze-thaw cycles.
 - Protect the stock solution from light by using amber vials or wrapping them in foil.
 - Perform a stability check of your stock solution using High-Performance Liquid Chromatography (HPLC) if available.

Potential Cause 2: Precipitation of **AR-C117977** in the experimental medium.

- Troubleshooting:
 - Visually inspect your final experimental solution for any signs of precipitation or cloudiness.
 - If precipitation is observed, refer to the troubleshooting steps in FAQ Q3.
 - Consider preparing the final dilution immediately before adding it to your cells or starting your experiment to minimize the time the compound spends in an aqueous environment where it may be less stable.

Problem 2: Difficulty in establishing a stable and reproducible formulation for in vivo studies.

The poor aqueous solubility of **AR-C117977** presents a significant challenge for in vivo formulation.

Potential Solution 1: Use of co-solvents and excipients.

- Approach: A formulation development study is recommended. This involves screening various pharmaceutically acceptable co-solvents (e.g., polyethylene glycol, ethanol), surfactants (e.g., Tween 80, Cremophor EL), and cyclodextrins to identify a vehicle that can solubilize and stabilize **AR-C117977** for administration.

Potential Solution 2: Nanosuspension or liposomal formulations.

- Approach: Advanced formulation strategies such as creating a nanosuspension or encapsulating **AR-C117977** in liposomes can significantly improve its solubility and bioavailability for in vivo applications.

Data Presentation

Table 1: Recommended Solvents for **AR-C117977** Stock Solution Preparation

Solvent	Recommended Concentration Range	Notes
DMSO	10 - 50 mM	Primary choice for in vitro stock solutions.
Ethanol	5 - 20 mM	May be used as an alternative or co-solvent.
Water	Insoluble	Not recommended for initial stock preparation.

Note: The provided concentration ranges are estimates based on the properties of similar small molecule inhibitors. It is recommended to determine the exact solubility in your specific laboratory conditions.

Experimental Protocols

Protocol 1: Preparation of **AR-C117977** Stock Solution

- Weighing: Accurately weigh the desired amount of **AR-C117977** powder in a sterile microcentrifuge tube.

- **Solvent Addition:** Add the calculated volume of high-purity DMSO to achieve the desired stock concentration (e.g., 10 mM).
- **Dissolution:** Vortex the solution for 1-2 minutes until the compound is completely dissolved. Gentle warming in a 37°C water bath can be used to aid dissolution if necessary.
- **Sterilization:** Sterilize the stock solution by filtering it through a 0.22 µm syringe filter into a sterile, light-protected container.
- **Aliquoting and Storage:** Aliquot the sterile stock solution into single-use, amber-colored microcentrifuge tubes. Store the aliquots at -20°C or -80°C.

Protocol 2: Forced Degradation Study of AR-C117977

A forced degradation study is essential to understand the intrinsic stability of **AR-C117977** and to develop a stability-indicating analytical method.

- **Sample Preparation:** Prepare solutions of **AR-C117977** (e.g., 1 mg/mL) in a suitable solvent system (e.g., acetonitrile:water 50:50).
- **Stress Conditions:** Expose the prepared solutions to the following stress conditions:
 - **Acid Hydrolysis:** Add 0.1 M HCl and incubate at 60°C for 24 hours.
 - **Base Hydrolysis:** Add 0.1 M NaOH and incubate at 60°C for 24 hours.
 - **Oxidative Degradation:** Add 3% H₂O₂ and incubate at room temperature for 24 hours.
 - **Thermal Degradation:** Incubate at 80°C for 48 hours.
 - **Photolytic Degradation:** Expose to UV light (254 nm) for 24 hours.
- **Neutralization:** Neutralize the acid and base-stressed samples with an equivalent amount of base or acid, respectively.
- **Analysis:** Analyze all stressed samples, along with an unstressed control, using a suitable analytical method like HPLC with a photodiode array (PDA) detector to identify and quantify any degradation products.

Mandatory Visualization

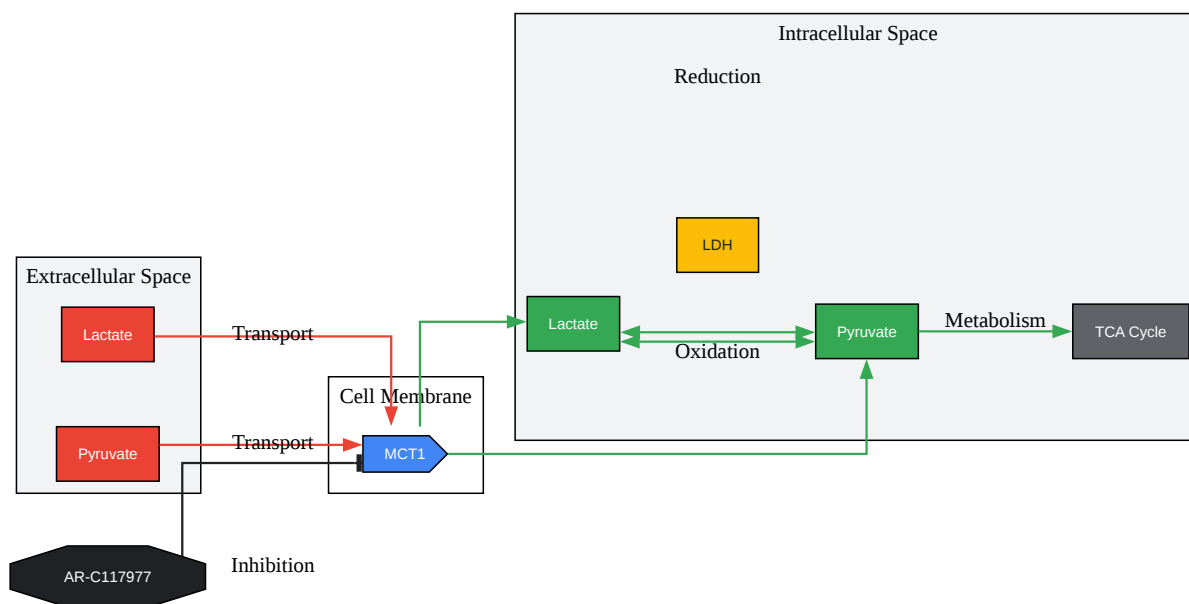

[Click to download full resolution via product page](#)

Caption: Mechanism of **AR-C117977** as an inhibitor of the MCT1 transporter.

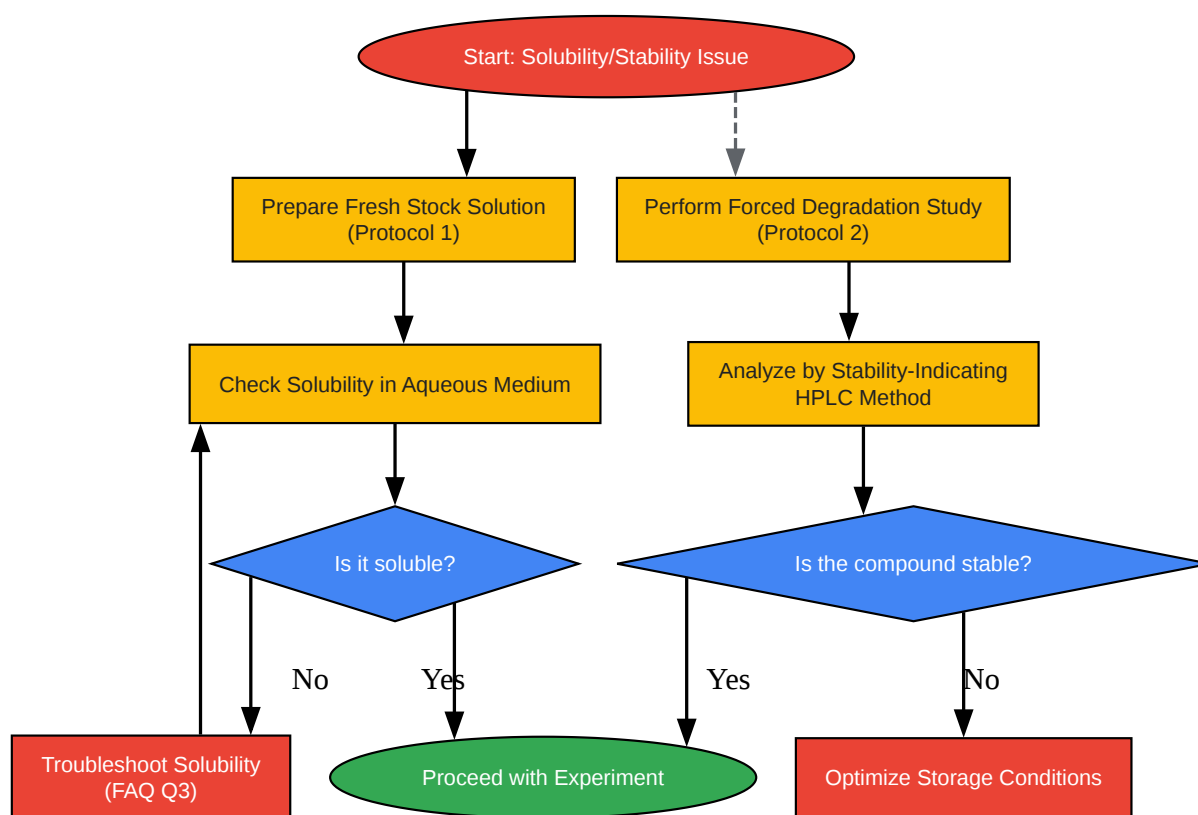

[Click to download full resolution via product page](#)

Caption: Troubleshooting workflow for **AR-C117977** solubility and stability issues.

Need Custom Synthesis?

BenchChem offers custom synthesis for rare earth carbides and specific isotopic labeling.

Email: info@benchchem.com or [Request Quote Online](#).

References

- 1. medchemexpress.com [medchemexpress.com]
- To cite this document: BenchChem. [How to address AR-C117977 solubility and stability issues.]. BenchChem, [2025]. [Online PDF]. Available at:

[<https://www.benchchem.com/product/b1665596#how-to-address-ar-c117977-solubility-and-stability-issues>]

Disclaimer & Data Validity:

The information provided in this document is for Research Use Only (RUO) and is strictly not intended for diagnostic or therapeutic procedures. While BenchChem strives to provide accurate protocols, we make no warranties, express or implied, regarding the fitness of this product for every specific experimental setup.

Technical Support: The protocols provided are for reference purposes. Unsure if this reagent suits your experiment? [[Contact our Ph.D. Support Team for a compatibility check](#)]

Need Industrial/Bulk Grade? [Request Custom Synthesis Quote](#)

BenchChem

Our mission is to be the trusted global source of essential and advanced chemicals, empowering scientists and researchers to drive progress in science and industry.

Contact

Address: 3281 E Guasti Rd
Ontario, CA 91761, United States
Phone: (601) 213-4426
Email: info@benchchem.com