

Acrihellin in the Study of Heart Failure Models: Application Notes and Protocols

Author: BenchChem Technical Support Team. **Date:** April 2026

Compound of Interest

Compound Name:	Acrihellin
CAS No.:	67696-82-6
Cat. No.:	B1665002

[Get Quote](#)

For Researchers, Scientists, and Drug Development Professionals

Introduction

Acrihellin is a potent cardiac glycoside that, like other members of its class such as digoxin and ouabain, exerts a positive inotropic effect on the heart muscle. The primary mechanism of action for cardiac glycosides is the inhibition of the Na⁺/K⁺-ATPase enzyme in cardiomyocytes. [1][2] This inhibition leads to an increase in intracellular sodium concentration, which in turn affects the sodium-calcium exchanger, resulting in a higher intracellular calcium concentration. [2][3] The elevated calcium levels enhance the contractility of the cardiac muscle, making cardiac glycosides a subject of interest in the context of heart failure.[2]

While the therapeutic use of cardiac glycosides in heart failure has a long history, research into specific glycosides like **Acrihellin** is ongoing. Preclinical studies in heart failure models are crucial for elucidating the unique pharmacological profile of such compounds. Although extensive in vivo data on **Acrihellin** in heart failure models are limited in publicly available literature, in vitro studies have characterized its positive inotropic effects.

These application notes provide a summary of the available data on **Acrihellin** and detailed protocols for key experiments to study its effects. The methodologies are based on established techniques for evaluating cardiac glycosides.

Data Presentation

The following table summarizes the quantitative data from an in vitro study on the positive inotropic effect of **Acrihellin** on guinea pig left atria.

Table 1: Dose-Response of **Acrihellin** on Inotropic Effect in Isolated Guinea Pig Left Atria

Acrihellin Concentration (mol/L)	Increase in Force of Contraction (% of maximum)
1×10^{-7}	10
3×10^{-7}	40
1×10^{-6}	80
3×10^{-6}	95
1×10^{-5}	100

Data adapted from Herzig et al., Naunyn-Schmiedeberg's Archives of Pharmacology, 1987.

Signaling Pathway

The diagram below illustrates the generally accepted signaling pathway for cardiac glycosides, which is applicable to **Acrihellin**.

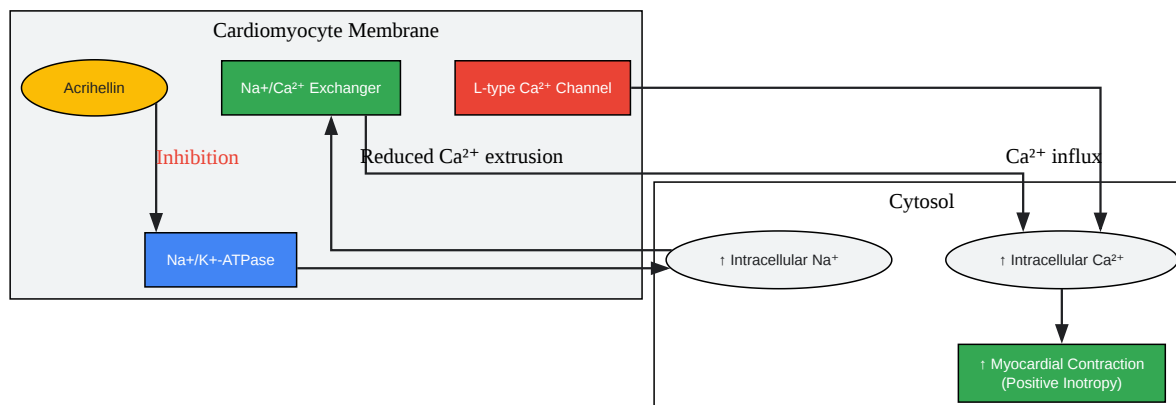

[Click to download full resolution via product page](#)

Caption: Signaling pathway of **Acrihellin** leading to increased myocardial contraction.

Experimental Protocols

Protocol 1: Assessment of Inotropic Effects of Acrihellin on Isolated Atrial Preparations

This protocol is designed to measure the direct effects of **Acrihellin** on the contractility of cardiac tissue, based on the methodology described for studying **Acrihellin**'s inotropic effects.

1. Materials:

- **Acrihellin**
- Ouabain (for comparison)
- Tyrode's solution (composition in mM: NaCl 137, KCl 2.7, CaCl₂ 1.8, MgCl₂ 1.0, NaH₂PO₄ 0.4, NaHCO₃ 11.9, Glucose 5.5)

- Isolated tissue bath with a force transducer
- Carbogen gas (95% O₂, 5% CO₂)
- Animal model (e.g., Guinea Pig)

2. Procedure:

- Tissue Preparation:
 - Humanely euthanize the guinea pig in accordance with institutional guidelines.
 - Rapidly excise the heart and place it in oxygenated, cold Tyrode's solution.
 - Dissect the left atrium and mount it in the isolated tissue bath containing Tyrode's solution maintained at 37°C and bubbled with Carbogen gas.
- Equilibration:
 - Allow the atrial preparation to equilibrate for at least 60 minutes, with regular changes of the Tyrode's solution.
 - Apply a resting tension of 10 mN and stimulate the atrium at a frequency of 1 Hz.
- Experimental Protocol:
 - After equilibration, record the baseline force of contraction.
 - Prepare a stock solution of **Acridhellin** in a suitable solvent (e.g., DMSO) and make serial dilutions in Tyrode's solution.
 - Add **Acridhellin** to the tissue bath in a cumulative manner, allowing the contractile response to stabilize at each concentration before adding the next. A suggested concentration range is 10⁻⁸ M to 10⁻⁵ M.
 - Record the force of contraction at each concentration.

- Note: Due to the amphiphilic nature of **Acrihellin**, it may escape from the gassed solution. It is crucial to use a closed system or to verify the actual concentration in the bath during the experiment.
- Data Analysis:
 - Express the increase in the force of contraction as a percentage of the baseline value.
 - Construct a dose-response curve by plotting the percentage increase in force against the logarithm of the **Acrihellin** concentration.
 - Calculate the EC₅₀ value (the concentration that produces 50% of the maximal response).

Protocol 2: Na⁺/K⁺-ATPase Inhibition Assay

This protocol provides a method to determine the inhibitory effect of **Acrihellin** on its primary molecular target.

1. Materials:

- **Acrihellin**
- Na⁺/K⁺-ATPase enzyme preparation (commercially available or prepared from animal tissue)
- Assay buffer (e.g., 50 mM Tris-HCl, pH 7.4, 100 mM NaCl, 20 mM KCl, 4 mM MgCl₂)
- ATP (Adenosine triphosphate)
- Malachite green reagent for phosphate detection
- Microplate reader

2. Procedure:

- Preparation:
 - Prepare serial dilutions of **Acrihellin** in the assay buffer. Also, prepare a vehicle control (DMSO in assay buffer) and a positive control (e.g., ouabain).

- Enzyme Reaction:
 - In a 96-well plate, add the Na⁺/K⁺-ATPase enzyme preparation to each well.
 - Add the different concentrations of **Acrihellin** or controls to the respective wells.
 - Pre-incubate the plate at 37°C for 15 minutes.
 - Initiate the enzymatic reaction by adding ATP to each well (final concentration typically 1-3 mM).
 - Incubate the plate at 37°C for a defined period (e.g., 30 minutes).
- Detection of Phosphate:
 - Stop the reaction by adding the malachite green reagent. This reagent will form a colored complex with the inorganic phosphate released from ATP hydrolysis.
 - Measure the absorbance at a wavelength of 620-640 nm using a microplate reader.
- Data Analysis:
 - The amount of phosphate produced is proportional to the Na⁺/K⁺-ATPase activity.
 - Calculate the percentage of inhibition for each **Acrihellin** concentration relative to the vehicle control.
 - Plot the percentage of inhibition against the logarithm of the **Acrihellin** concentration to determine the IC₅₀ value (the concentration that causes 50% inhibition).

Experimental Workflow Visualization

The following diagram illustrates the experimental workflow for assessing the inotropic effects of **Acrihellin** on isolated atrial preparations.

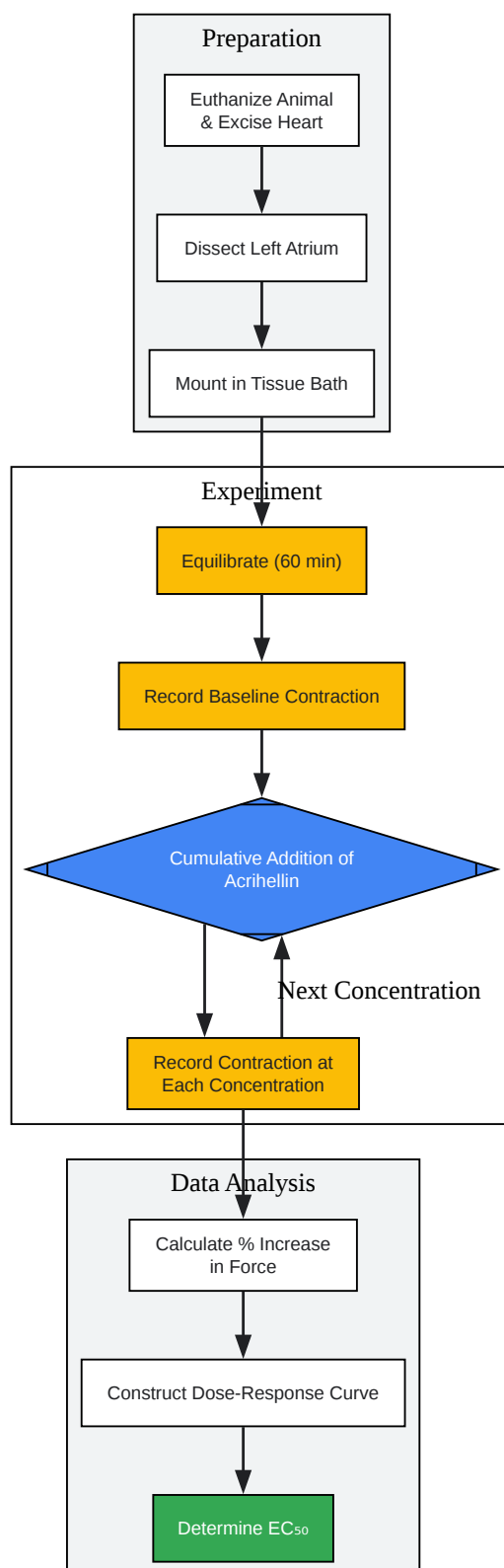

[Click to download full resolution via product page](#)

Caption: Workflow for isolated atrial preparation experiment.

Need Custom Synthesis?

BenchChem offers custom synthesis for rare earth carbides and specific isotopic labeling.

Email: info@benchchem.com or [Request Quote Online](#).

References

- 1. Acrihellin, a cardioactive steroid escaping from the organ-bath - PubMed [pubmed.ncbi.nlm.nih.gov]
- 2. [Effect of anapriline on the pharmacodynamic effects of strophanthin in experiments on isolated myocardial preparations and under conditions of simulation of cardiac insufficiency] - PubMed [pubmed.ncbi.nlm.nih.gov]
- 3. Apelin has in vivo inotropic effects on normal and failing hearts - PubMed [pubmed.ncbi.nlm.nih.gov]
- To cite this document: BenchChem. [Acrihellin in the Study of Heart Failure Models: Application Notes and Protocols]. BenchChem, [2026]. [Online PDF]. Available at: [<https://www.benchchem.com/product/b1665002/docs#acrihellin-in-the-study-of-heart-failure-models-application-notes-and-protocols>]

Disclaimer & Data Validity:

The information provided in this document is for Research Use Only (RUO) and is strictly not intended for diagnostic or therapeutic procedures. While BenchChem strives to provide accurate protocols, we make no warranties, express or implied, regarding the fitness of this product for every specific experimental setup.

Technical Support: The protocols provided are for reference purposes. Unsure if this reagent suits your experiment?

Need Industrial/Bulk Grade? [Request Custom Synthesis Quote](#)

BenchChem

Our mission is to be the trusted global source of essential and advanced chemicals, empowering scientists and researchers to drive progress in science and industry.

Contact

Address: 3281 E Guasti Rd

Ontario, CA 91761, United States

Phone: (601) 213-4426

Email: info@benchchem.com

[Contact our Ph.D. Support Team for a compatibility check](#)