

Navigating the Stability of 2-Methoxycinnamic Acid Solutions: A Technical Guide

Author: BenchChem Technical Support Team. **Date:** April 2026

Compound of Interest

Compound Name: 2-Methoxycinnamic acid

CAS No.: 1011-54-7

Cat. No.: B1664561

[Get Quote](#)

BETHESDA, MD – November 6, 2025 – To support researchers, scientists, and drug development professionals in ensuring the integrity and reproducibility of their experiments, this technical support guide provides detailed information on the long-term storage and stability of **2-Methoxycinnamic acid** solutions. This document addresses common issues encountered during experimental workflows, offering troubleshooting advice and frequently asked questions.

Understanding the Stability of 2-Methoxycinnamic Acid

2-Methoxycinnamic acid is a derivative of cinnamic acid that is noted for its poor solubility in water but is soluble in organic solvents such as ethanol and acetone. While generally stable as a solid under cool, dry, and well-ventilated conditions, its stability in solution is a critical factor for experimental success. Solutions of **2-Methoxycinnamic acid** are known to be sensitive to light and heat, which can impact the compound's potency. It is generally recommended that solutions are not stored for long periods and are used promptly after preparation.

Frequently Asked Questions (FAQs)

Q1: What are the primary factors that cause the degradation of **2-Methoxycinnamic acid** solutions?

A1: The primary factors leading to the degradation of **2-Methoxycinnamic acid** in solution are exposure to light (photodegradation), elevated temperatures (thermal degradation), and extreme pH conditions.

Q2: My **2-Methoxycinnamic acid** solution has changed color. Is it still usable?

A2: A change in color, such as yellowing, can be an indicator of degradation. It is recommended to perform an analytical check, such as HPLC, to determine the purity of the solution. If significant degradation has occurred, the solution should be discarded and a fresh one prepared.

Q3: Can I store my **2-Methoxycinnamic acid** solution at room temperature?

A3: Storing **2-Methoxycinnamic acid** solutions at room temperature is not recommended for long-term stability, as thermal degradation can occur. For short-term storage, protection from light is crucial.

Q4: What are the expected degradation products of **2-Methoxycinnamic acid**?

A4: Based on studies of related methoxycinnamic acid derivatives, potential degradation products can result from photodegradation and thermal decomposition. Photodegradation of a similar compound, 2-ethylhexyl 4-methoxycinnamate, has been shown to yield products such as 4-methoxycinnamic acid, 4-methoxybenzaldehyde, and 4-methoxyphenol. Thermal decomposition of 4-methoxycinnamic acid has been observed to proceed through decarbonylation, decarboxylation, and dehydration.

Troubleshooting Guide

Issue	Potential Cause	Recommended Action
Precipitate forms in the solution upon storage.	The concentration of 2-Methoxycinnamic acid may exceed its solubility in the chosen solvent at the storage temperature.	Gently warm the solution and agitate to redissolve the precipitate. If it persists, consider preparing a more dilute solution or using a different solvent with higher solubility.
Inconsistent experimental results using the same stock solution.	The stock solution may have degraded over time due to improper storage (exposure to light or elevated temperatures).	Prepare a fresh stock solution of 2-Methoxycinnamic acid and store it protected from light in a refrigerator or freezer. Perform a stability check of the old stock solution using HPLC if possible.
Appearance of unexpected peaks in HPLC analysis.	These peaks may correspond to degradation products of 2-Methoxycinnamic acid.	Refer to the potential degradation products listed in the FAQs. Use a stability-indicating HPLC method to identify and quantify the degradants. Adjust storage conditions to minimize further degradation.

Recommended Storage Conditions

To ensure the long-term stability of **2-Methoxycinnamic acid** solutions, the following storage conditions are recommended. Data presented is based on general guidelines for cinnamic acid derivatives and forced degradation studies.

Storage Condition	Solvent	Recommended Temperature	Light Exposure	Expected Stability (Illustrative)
Short-Term (≤ 1 week)	Ethanol, DMSO	2-8°C	Protected from light (amber vials)	>98% Purity
Long-Term (> 1 week)	Ethanol, DMSO	-20°C	Protected from light (amber vials)	>95% Purity over 1 month
Aqueous Buffers (pH 5-7)	Buffered Saline	2-8°C (Short-term only)	Protected from light (amber vials)	Use immediately; prone to precipitation

Note: The stability data is illustrative and can vary based on the specific experimental conditions. It is highly recommended to perform your own stability studies for critical applications.

Experimental Protocols

Protocol 1: Preparation of a Standard 2-Methoxycinnamic Acid Stock Solution

- Materials: **2-Methoxycinnamic acid** (solid), Anhydrous Ethanol or DMSO, Class A volumetric flask, analytical balance.
- Procedure:
 - Accurately weigh the desired amount of **2-Methoxycinnamic acid**.
 - Transfer the solid to the volumetric flask.
 - Add a small amount of the solvent (Ethanol or DMSO) to dissolve the solid completely.
 - Once dissolved, add the solvent to the final volume.
 - Mix the solution thoroughly.

6. Store the solution in an amber vial at the recommended temperature.

Protocol 2: Stability-Indicating HPLC Method for 2-Methoxycinnamic Acid

This method is designed to separate **2-Methoxycinnamic acid** from its potential degradation products.

- Instrumentation: HPLC system with a UV detector.
- Chromatographic Conditions:
 - Column: C18 reverse-phase column (e.g., 4.6 x 250 mm, 5 μ m).
 - Mobile Phase: A gradient of acetonitrile and water with 0.1% formic acid.
 - Flow Rate: 1.0 mL/min.
 - Detection Wavelength: 280 nm.
 - Injection Volume: 10 μ L.
- Sample Preparation: Dilute the **2-Methoxycinnamic acid** solution to be tested to a suitable concentration with the mobile phase.
- Analysis: Inject the sample and monitor the chromatogram for the appearance of new peaks and a decrease in the peak area of the parent compound.

Visualizing Potential Mechanisms of Action

2-Methoxycinnamic acid, similar to other cinnamic acid derivatives like ferulic acid, may influence cellular processes such as apoptosis and cell cycle regulation, which are critical in cancer research.

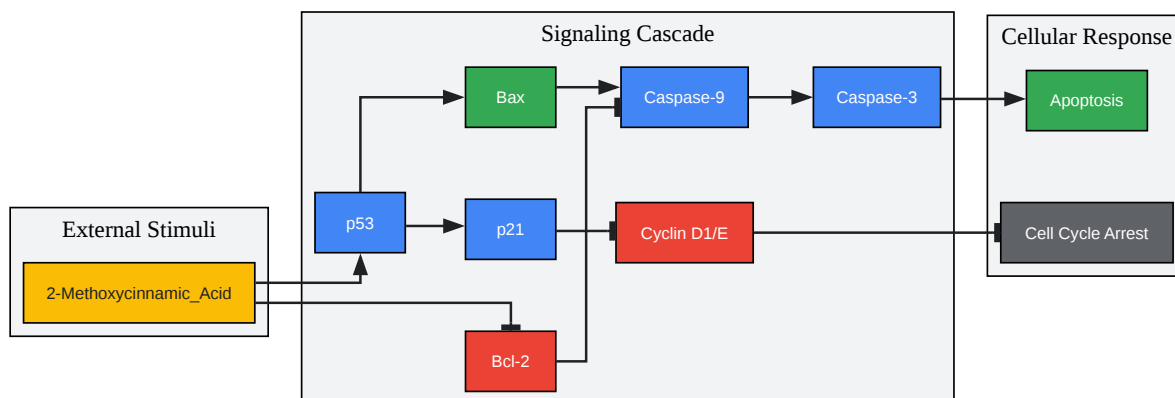

[Click to download full resolution via product page](#)

Caption: Potential signaling pathway of **2-Methoxycinnamic acid** in inducing apoptosis and cell cycle arrest.

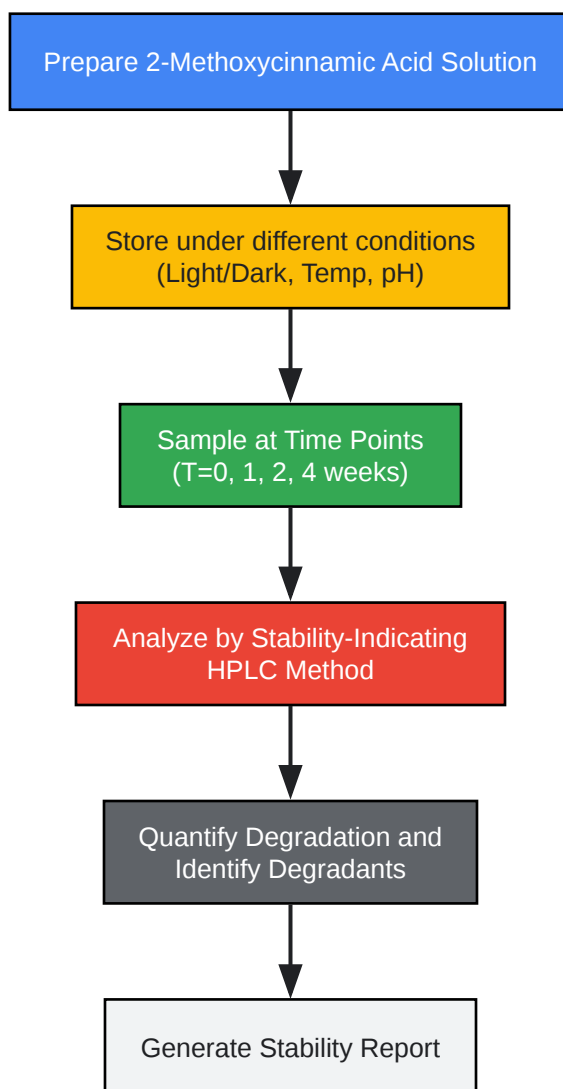

[Click to download full resolution via product page](#)

Caption: Experimental workflow for assessing the stability of **2-Methoxycinnamic acid** solutions.

- To cite this document: BenchChem. [Navigating the Stability of 2-Methoxycinnamic Acid Solutions: A Technical Guide]. BenchChem, [2026]. [Online PDF]. Available at: [<https://www.benchchem.com/product/b1664561/docs#navigating-the-stability-of-2-methoxycinnamic-acid-solutions-a-technical-guide>]

Disclaimer & Data Validity:

The information provided in this document is for Research Use Only (RUO) and is strictly not intended for diagnostic or therapeutic procedures. While BenchChem strives to provide accurate protocols, we make no warranties, express or implied, regarding the fitness of this product for every specific experimental setup.

Technical Support: The protocols provided are for reference purposes. Unsure if this reagent suits your experiment?

Need Industrial/Bulk Grade? [Request Custom Synthesis Quote](#)

BenchChem

Our mission is to be the trusted global source of essential and advanced chemicals, empowering scientists and researchers to drive progress in science and industry.

Contact

Address: 3281 E Guasti Rd
Ontario, CA 91761, United States
Phone: (601) 213-4426
Email: info@benchchem.com

[Contact our Ph.D. Support Team for a compatibility check](#)