

Desoxyrhapontigenin: A Technical Guide to Natural Sources and Isolation

Author: BenchChem Technical Support Team. **Date:** April 2026

Compound of Interest

Compound Name: *Desoxyrhapontigenin*

CAS No.: 33626-08-3

Cat. No.: B1664620

[Get Quote](#)

For Researchers, Scientists, and Drug Development Professionals

Introduction

Desoxyrhapontigenin is a stilbenoid, a class of natural phenolic compounds, that has garnered significant interest in the scientific community for its diverse pharmacological activities. As a derivative of resveratrol, it exhibits a range of biological effects, including anti-inflammatory, antioxidant, and anticancer properties. This technical guide provides an in-depth overview of the natural sources of **desoxyrhapontigenin**, detailed methodologies for its isolation and purification, quantitative data on its prevalence in various plant species, and an exploration of the key signaling pathways it modulates.

Natural Sources of Desoxyrhapontigenin

Desoxyrhapontigenin is primarily found in plants of the Rheum (rhubarb) and Gnetum genera.

Rheum Species

The roots and rhizomes of various rhubarb species are the most abundant natural sources of **desoxyrhapontigenin**. Notable species include:

- Rheum undulatum: Frequently cited as a primary source for the isolation of **desoxyrhapontigenin**[1].
- Rheum rhaponticum (Rhapontic Rhubarb): Contains a significant amount of **desoxyrhapontigenin** and its glycoside, desoxyrhaponticin[2].
- Rheum rhabarbarum (Garden Rhubarb)
- Rheum emodi (Himalayan Rhubarb)
- Rheum officinale (Chinese Rhubarb)

Gnetum Species

Certain species of the Gnetum genus, woody climbing plants found in tropical regions, have also been identified as sources of various stilbenoids, including **desoxyrhapontigenin**, although typically in lower concentrations than in Rheum species.

Isolation and Purification of Desoxyrhapontigenin

The isolation of **desoxyrhapontigenin** from its natural sources typically involves extraction, fractionation, and chromatographic purification. The following protocols are based on established methodologies.

Experimental Protocol: Isolation from Rheum undulatum

This protocol provides a detailed method for the isolation and purification of **desoxyrhapontigenin** from the roots of Rheum undulatum.

2.1.1. Plant Material and Extraction

- Plant Material Preparation: The roots of R. undulatum are collected, washed, cut into small pieces, dried, and milled into a fine powder[1].

- Extraction: The powdered plant material (e.g., 4.5 kg) is extracted with methanol (3 x 15 L) for 5 hours per extraction at 45°C. The extracts are then combined, filtered, and concentrated under reduced pressure at 45-50°C to yield a crude extract[1].

2.1.2. Fractionation

- The crude methanol extract is sequentially fractionated by solvent-solvent partitioning with dichloromethane, followed by ethyl acetate, and then water[1].
- The dichloromethane fraction, which is enriched with stilbenoids, is concentrated to dryness.

2.1.3. Chromatographic Purification

- Silica Gel Column Chromatography: A portion of the dried dichloromethane fraction (e.g., 60 g) is subjected to silica gel column chromatography.
 - Stationary Phase: Silica gel.
 - Mobile Phase: A gradient of increasing ethyl acetate percentage (from 25% to 100%) in hexane is used for elution, yielding several fractions (e.g., D1, D2, D3, and D4).
- Further Silica Gel Chromatography: The fraction containing **desoxyrhapontigenin** (e.g., D2) is further purified by silica gel column chromatography using a different solvent system.
 - Mobile Phase: A gradient of increasing methanol percentage (from 2% to 100%) in dichloromethane.
 - Fractions are monitored by thin-layer chromatography (TLC), and those containing the compound of interest are pooled and dried.
- High-Performance Liquid Chromatography (HPLC) Purification: The final purification is achieved by preparative HPLC to obtain high-purity **desoxyrhapontigenin** (>98%).
 - Column: X-Terra RP C18 column (e.g., 2.1 x 150 mm, 5 μm).
 - Mobile Phase: Isocratic elution with a mixture of methanol and water (1:1) containing 0.1% formic acid.

- Flow Rate: 0.2 mL/min.
- Detection: UV detector.
- Crystallization: The purified **desoxyrhapontigenin** can be crystallized to obtain a solid form.

Experimental Protocol: General Method for Stilbenoid Isolation from Gnetum Species

While a specific protocol for **desoxyrhapontigenin** from Gnetum is less common, the following general method for stilbenoid isolation can be adapted.

2.2.1. Plant Material and Extraction

- Plant Material Preparation: The dried and pulverized lianas of the Gnetum species are used.
- Extraction: The plant material is extracted with acetone at room temperature. The acetone extract is then concentrated.

2.2.2. Fractionation and Purification

- Solvent Partitioning: The crude acetone extract is dissolved in methanol and partitioned with diethyl ether to remove tannins.
- Vacuum Liquid Chromatography (VLC): The ether-soluble fraction is subjected to VLC on silica gel.
 - Mobile Phase: A gradient of hexane and ethyl acetate, followed by ethyl acetate and methanol.
- Radial and Column Chromatography: Fractions obtained from VLC are further purified using repetitive radial chromatography and silica gel column chromatography with various solvent systems (e.g., hexane:acetone) to isolate individual stilbenoids.

Quantitative Data

The concentration of **desoxyrhapontigenin** and its glycoside, desoxyrhaponticin, can vary significantly depending on the plant species, geographical location, and the extraction method

employed.

| Plant Species | Plant Part | Compound | Concentration (mg/g of dry weight) | Analytical Method | Reference |
|-------------------|------------|-------------------|------------------------------------|-------------------|-----------|
| Rheum rhaponticum | Roots | Rhaponticin | up to 184.0 ± 10.93 | HPLC | |
| Rheum rhabarbarum | Roots | Rhaponticin | up to 151.3 ± 7.77 | HPLC | |
| Rheum undulatum | Rhizomes | Desoxyrhaponticin | 0.3 - 31.5 | TLC | |
| Rheum rhaponticum | Rhizomes | Desoxyrhaponticin | 0.3 - 31.5 | TLC | |

Signaling Pathways Modulated by Desoxyrhapontigenin

Desoxyrhapontigenin exerts its biological effects by modulating several key intracellular signaling pathways, primarily the NF-κB and MAPK pathways, and by inducing apoptosis through endoplasmic reticulum (ER) stress.

Inhibition of the NF-κB Signaling Pathway

Desoxyrhapontigenin has been shown to be a potent inhibitor of the NF-κB signaling pathway, a critical regulator of inflammation.

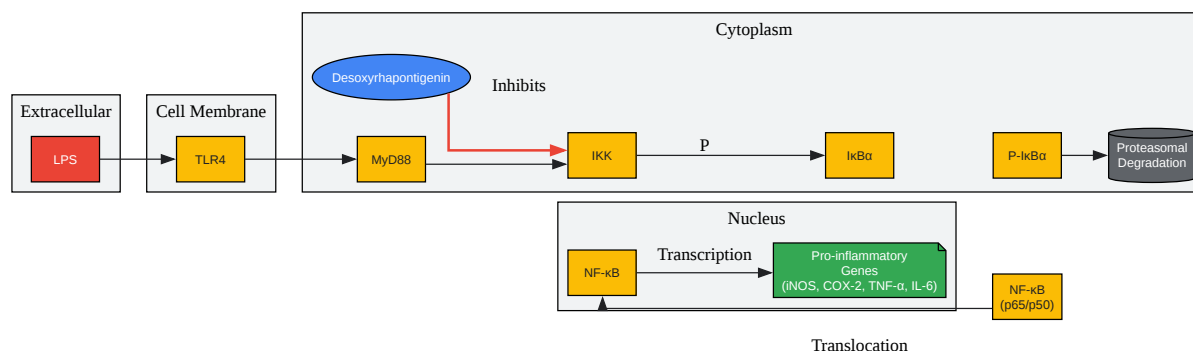

[Click to download full resolution via product page](#)

Caption: **Desoxyrhapontigenin** inhibits the NF-κB pathway.

Desoxyrhapontigenin inhibits the phosphorylation of IκB kinase (IKK), which in turn prevents the phosphorylation and subsequent proteasomal degradation of IκBα. This stabilizes the IκBα-NF-κB complex in the cytoplasm, preventing the translocation of the NF-κB (p65/p50) dimer to the nucleus. As a result, the transcription of NF-κB target genes, including those encoding pro-inflammatory cytokines (TNF-α, IL-6) and enzymes (iNOS, COX-2), is suppressed.

Modulation of the MAPK Signaling Pathway

The mitogen-activated protein kinase (MAPK) pathway is another crucial signaling cascade involved in cellular processes like inflammation, proliferation, and apoptosis.

Desoxyrhapontigenin modulates this pathway by affecting the phosphorylation of key kinases.

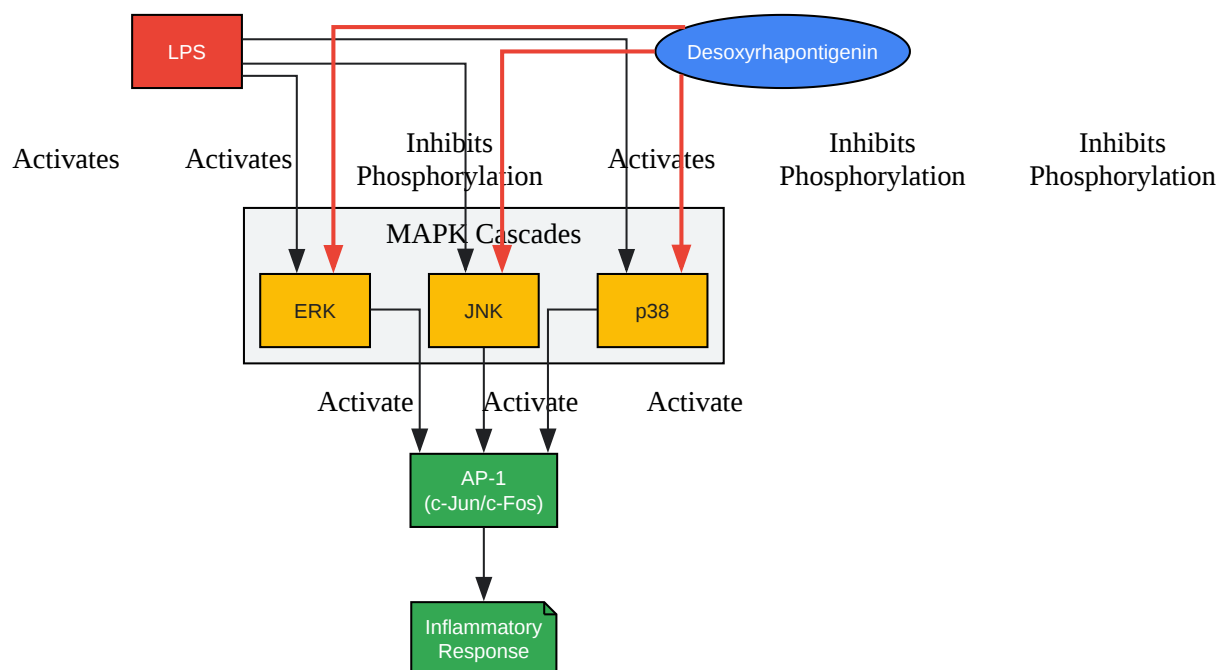

[Click to download full resolution via product page](#)

Caption: **Desoxyrhapontigenin** modulates the MAPK pathway.

Desoxyrhapontigenin has been observed to inhibit the phosphorylation of extracellular signal-regulated kinase (ERK), c-Jun N-terminal kinase (JNK), and p38 MAPK. By downregulating the activation of these kinases, **desoxyrhapontigenin** can suppress the activation of downstream transcription factors like AP-1 (a dimer of c-Jun and c-Fos), which further contributes to its anti-inflammatory effects.

Induction of Apoptosis via Endoplasmic Reticulum (ER) Stress

In the context of cancer, **desoxyrhapontigenin** has been shown to induce apoptosis in cancer cells through the activation of the ER stress pathway.

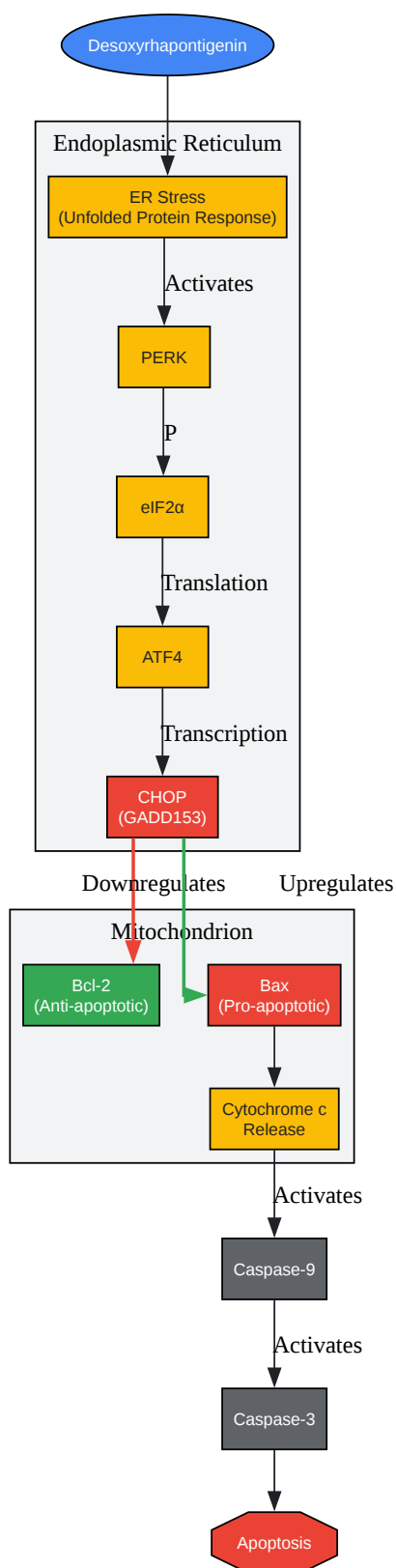

[Click to download full resolution via product page](#)

Caption: **Desoxyrhaptogenin** induces apoptosis via ER stress.

Desoxyrhapontigenin induces ER stress, leading to the activation of the unfolded protein response (UPR). A key event in this process is the phosphorylation of PERK, which leads to the preferential translation of ATF4. ATF4, a transcription factor, then upregulates the expression of CHOP (also known as GADD153). CHOP plays a crucial role in promoting apoptosis by downregulating the anti-apoptotic protein Bcl-2 and upregulating pro-apoptotic proteins like Bax. This shift in the Bcl-2 family protein balance leads to mitochondrial outer membrane permeabilization, cytochrome c release, and the subsequent activation of the caspase cascade (caspase-9 and caspase-3), ultimately resulting in apoptotic cell death.

Experimental Workflow

The overall workflow for the isolation and characterization of **desoxyrhapontigenin** from a natural source is summarized below.

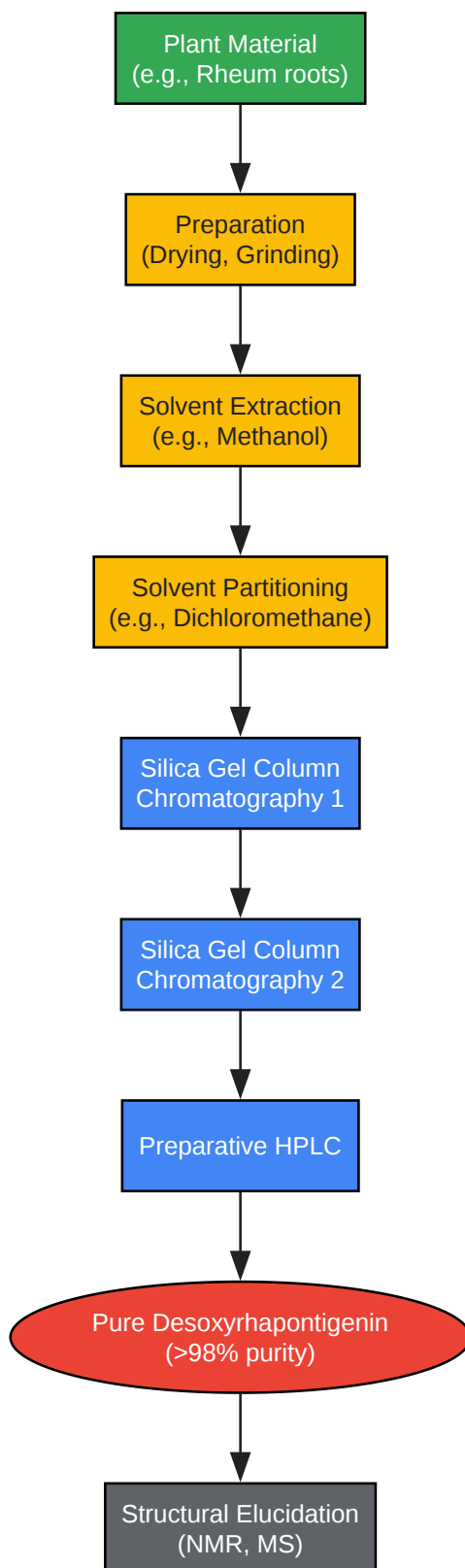

[Click to download full resolution via product page](#)

Caption: Experimental workflow for **desoxyrhapontigenin** isolation.

Conclusion

Desoxyrhapontigenin represents a promising natural product with significant therapeutic potential. This guide has outlined its primary natural sources, provided detailed protocols for its isolation and purification, presented quantitative data on its occurrence, and elucidated the key signaling pathways through which it exerts its biological effects. The methodologies and data presented herein are intended to serve as a valuable resource for researchers in the fields of natural product chemistry, pharmacology, and drug development, facilitating further investigation into the therapeutic applications of this compelling stilbenoid.

Need Custom Synthesis?

BenchChem offers custom synthesis for rare earth carbides and specific isotopic labeling.

Email: info@benchchem.com or [Request Quote Online](#).

References

- [1. Deoxyrhapontigenin, a Natural Stilbene Derivative Isolated From Rheum undulatum L. Induces Endoplasmic Reticulum Stress–Mediated Apoptosis in Human Breast Cancer Cells - PMC \[pmc.ncbi.nlm.nih.gov\]](#)
- [2. Rheum rhaponticum and Rheum rhabarbarum Extracts as Modulators of Endothelial Cell Inflammatory Response - PMC \[pmc.ncbi.nlm.nih.gov\]](#)
- To cite this document: BenchChem. [Desoxyrhapontigenin: A Technical Guide to Natural Sources and Isolation]. BenchChem, [2026]. [Online PDF]. Available at: [\[https://www.benchchem.com/product/b1664620/docs#desoxyrhapontigenin-a-technical-guide-to-natural-sources-and-isolation\]](https://www.benchchem.com/product/b1664620/docs#desoxyrhapontigenin-a-technical-guide-to-natural-sources-and-isolation)

Disclaimer & Data Validity:

The information provided in this document is for Research Use Only (RUO) and is strictly not intended for diagnostic or therapeutic procedures. While BenchChem strives to provide accurate protocols, we make no warranties, express or implied, regarding the fitness of this product for every specific experimental setup.

Technical Support: The protocols provided are for reference purposes. Unsure if this reagent suits your experiment?

Need Industrial/Bulk Grade? [Request Custom Synthesis Quote](#)

BenchChem

Our mission is to be the trusted global source of essential and advanced chemicals, empowering scientists and researchers to drive progress in science and industry.

Contact

Address: 3281 E Guasti Rd
Ontario, CA 91761, United States
Phone: (601) 213-4426
Email: info@benchchem.com

[Contact our Ph.D. Support Team for a compatibility check](#)