

Application Notes and Protocols for Measuring ABD56 Efficacy

Author: BenchChem Technical Support Team. **Date:** April 2026

Compound of Interest

Compound Name:	ABD56
CAS No.:	521294-19-9
Cat. No.:	B1664297

[Get Quote](#)

For Researchers, Scientists, and Drug Development Professionals

Introduction

ABD56 is a biphenylcarboxylic acid butanediol ester that has been identified as a potent inhibitor of osteoclast formation and activity. It serves as a valuable research tool for studying bone resorption and the signaling pathways that govern osteoclast differentiation and survival. These application notes provide detailed protocols for assessing the efficacy of **ABD56** in vitro, focusing on its ability to induce osteoclast apoptosis through the inhibition of the NF- κ B and ERK signaling pathways.

Mechanism of Action

ABD56 exerts its effects on osteoclasts primarily by inducing apoptosis. This programmed cell death is initiated through the targeted inhibition of key survival signals. Specifically, **ABD56** has been shown to abolish the RANKL (Receptor Activator of Nuclear Factor κ B Ligand)-induced phosphorylation of I κ B α and ERK1/2 (Extracellular signal-regulated kinases 1 and 2). The inhibition of these pathways disrupts the downstream signaling cascades essential for osteoclast survival and function, ultimately leading to apoptosis.[1]

Data Presentation

The efficacy of **ABD56** in inhibiting osteoclast formation has been quantified in murine cell cultures. The half-maximal inhibitory concentration (IC50) values provide a benchmark for its potency.

Assay	Cell Culture System	IC50 of ABD56
Osteoclast Formation	Mouse osteoblast-bone marrow co-cultures	26 μ M
Osteoclast Formation	M-CSF and RANKL-stimulated mouse bone marrow cultures	8 μ M

Experimental Protocols

Herein, we provide detailed protocols for key experiments to measure the efficacy of **ABD56**.

Protocol 1: In Vitro Osteoclastogenesis Assay

This protocol details the differentiation of bone marrow-derived macrophages (BMMs) into osteoclasts and the assessment of **ABD56**'s inhibitory effect on this process.

Materials:

- Mouse bone marrow cells
- Alpha-MEM (Minimum Essential Medium Eagle, Alpha Modification)
- Fetal Bovine Serum (FBS)
- Penicillin-Streptomycin solution
- M-CSF (Macrophage Colony-Stimulating Factor)
- RANKL (Receptor Activator of Nuclear Factor κ B Ligand)
- **ABD56** (stock solution in DMSO)

- TRAP (Tartrate-Resistant Acid Phosphatase) staining kit
- Phosphate Buffered Saline (PBS)
- Fixation solution (e.g., 4% paraformaldehyde in PBS)
- Multi-well culture plates (48- or 96-well)

Procedure:

- Isolation of Bone Marrow-Derived Macrophages (BMMs):
 - Harvest bone marrow from the femurs and tibias of mice.
 - Culture the cells in α -MEM supplemented with 10% FBS, 1% Penicillin-Streptomycin, and 30 ng/mL M-CSF for 3-4 days to generate BMMs.
- Osteoclast Differentiation:
 - Seed the BMMs into multi-well plates at a suitable density.
 - Culture the cells in differentiation medium containing α -MEM, 10% FBS, 1% Penicillin-Streptomycin, 30 ng/mL M-CSF, and 50 ng/mL RANKL.
 - Concurrently, treat the cells with varying concentrations of **ABD56** (e.g., 1 μ M to 50 μ M) or vehicle control (DMSO).
- Culture Maintenance:
 - Incubate the plates at 37°C in a humidified atmosphere with 5% CO₂.
 - Replace the medium with fresh differentiation medium and respective treatments every 2-3 days.
- TRAP Staining:
 - After 5-7 days of culture, when multinucleated osteoclasts are visible in the control wells, aspirate the medium.

- Wash the cells with PBS.
- Fix the cells with a fixation solution for 10 minutes at room temperature.
- Wash the cells again with PBS.
- Stain for TRAP activity using a commercially available kit according to the manufacturer's instructions.
- Quantification:
 - Count the number of TRAP-positive multinucleated cells (≥ 3 nuclei) in each well under a light microscope.
 - Calculate the percentage of inhibition of osteoclast formation for each **ABD56** concentration relative to the vehicle control.

Protocol 2: Osteoclast Apoptosis Assay (Annexin V/Propidium Iodide Staining)

This protocol describes how to quantify the pro-apoptotic effect of **ABD56** on mature osteoclasts using flow cytometry.

Materials:

- Mature osteoclasts (generated as described in Protocol 1)
- **ABD56**
- Annexin V-FITC Apoptosis Detection Kit
- Propidium Iodide (PI)
- Binding Buffer
- PBS
- Flow cytometer

Procedure:

- Treatment of Mature Osteoclasts:
 - Generate mature osteoclasts in culture plates as described in Protocol 1.
 - Treat the mature osteoclasts with different concentrations of **ABD56** or vehicle control for a specified period (e.g., 24 hours).
- Cell Harvesting:
 - Gently detach the cells from the plate using a cell scraper or a suitable non-enzymatic dissociation solution.
 - Wash the cells with cold PBS.
- Staining:
 - Resuspend the cells in Annexin V binding buffer.
 - Add Annexin V-FITC and Propidium Iodide to the cell suspension according to the manufacturer's protocol.
 - Incubate the cells in the dark for 15 minutes at room temperature.
- Flow Cytometry Analysis:
 - Analyze the stained cells using a flow cytometer.
 - Annexin V-positive, PI-negative cells are considered early apoptotic.
 - Annexin V-positive, PI-positive cells are considered late apoptotic or necrotic.
- Data Analysis:
 - Quantify the percentage of apoptotic cells in each treatment group.
 - Compare the apoptosis rates in **ABD56**-treated groups to the vehicle control.

Protocol 3: Western Blot Analysis of NF- κ B and ERK Signaling

This protocol outlines the procedure to detect the inhibitory effect of **ABD56** on the phosphorylation of I κ B α and ERK1/2.

Materials:

- Mature osteoclasts
- **ABD56**
- RANKL
- Lysis buffer (e.g., RIPA buffer with protease and phosphatase inhibitors)
- BCA Protein Assay Kit
- SDS-PAGE gels
- Transfer buffer
- PVDF or nitrocellulose membranes
- Blocking buffer (e.g., 5% non-fat milk or BSA in TBST)
- Primary antibodies: anti-phospho-I κ B α , anti-I κ B α , anti-phospho-ERK1/2, anti-ERK1/2, anti- β -actin (as a loading control)
- HRP-conjugated secondary antibodies
- Chemiluminescent substrate
- Imaging system

Procedure:

- Cell Treatment and Lysis:

- Culture mature osteoclasts and starve them of RANKL for a few hours.
- Pre-treat the cells with **ABD56** or vehicle control for a designated time (e.g., 1-2 hours).
- Stimulate the cells with RANKL (e.g., 100 ng/mL) for a short period (e.g., 5-15 minutes) to induce phosphorylation of I κ B α and ERK1/2.
- Wash the cells with cold PBS and lyse them with lysis buffer.
- Determine the protein concentration of the lysates using a BCA assay.
- SDS-PAGE and Western Blotting:
 - Separate equal amounts of protein from each sample on SDS-PAGE gels.
 - Transfer the separated proteins to a PVDF or nitrocellulose membrane.
 - Block the membrane with blocking buffer for 1 hour at room temperature.
 - Incubate the membrane with primary antibodies overnight at 4°C.
 - Wash the membrane with TBST.
 - Incubate the membrane with the appropriate HRP-conjugated secondary antibody for 1 hour at room temperature.
 - Wash the membrane again with TBST.
- Detection and Analysis:
 - Apply the chemiluminescent substrate and capture the signal using an imaging system.
 - Quantify the band intensities and normalize the levels of phosphorylated proteins to the total protein levels.
 - Compare the levels of phospho-I κ B α and phospho-ERK1/2 in **ABD56**-treated samples to the RANKL-stimulated control.

Visualizations

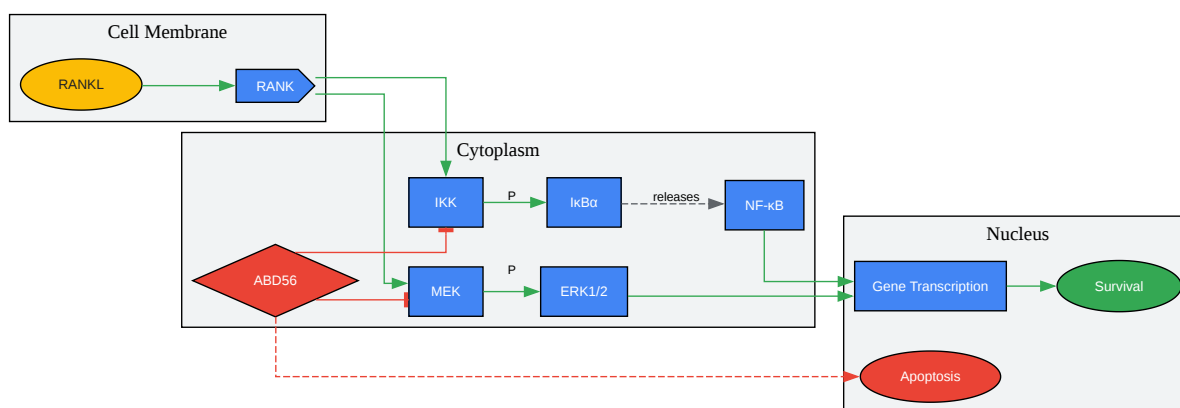

[Click to download full resolution via product page](#)

Caption: Mechanism of **ABD56**-induced osteoclast apoptosis.

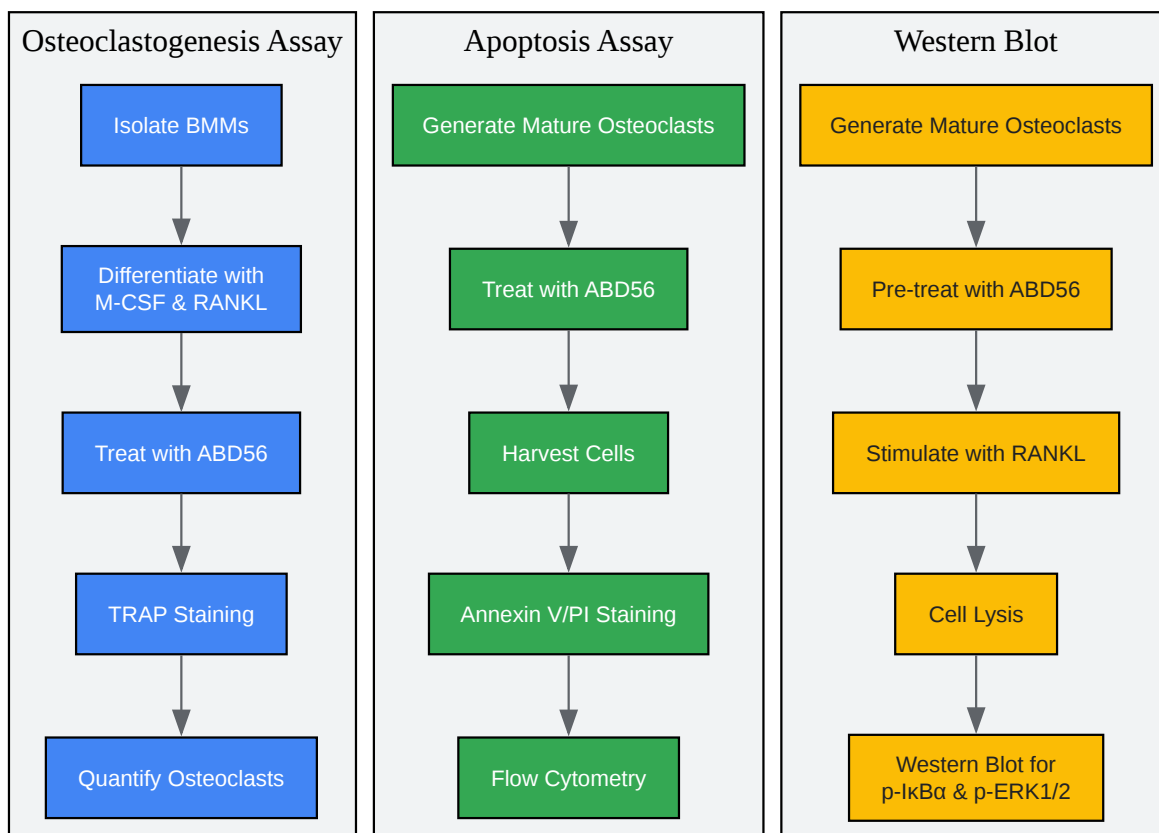

[Click to download full resolution via product page](#)

Caption: Workflow for measuring **ABD56** efficacy.

Need Custom Synthesis?

BenchChem offers custom synthesis for rare earth carbides and specific isotopic labeling.

Email: info@benchchem.com or [Request Quote Online](#).

References

- 1. researchonline.jcu.edu.au [researchonline.jcu.edu.au]

- To cite this document: BenchChem. [Application Notes and Protocols for Measuring ABD56 Efficacy]. BenchChem, [2026]. [Online PDF]. Available at: [<https://www.benchchem.com/product/b1664297/docs#application-notes-and-protocols-for-measuring-abd56-efficacy>]

Disclaimer & Data Validity:

The information provided in this document is for Research Use Only (RUO) and is strictly not intended for diagnostic or therapeutic procedures. While BenchChem strives to provide accurate protocols, we make no warranties, express or implied, regarding the fitness of this product for every specific experimental setup.

Technical Support: The protocols provided are for reference purposes. Unsure if this reagent suits your experiment?

Need Industrial/Bulk Grade? [Request Custom Synthesis Quote](#)

BenchChem

Our mission is to be the trusted global source of essential and advanced chemicals, empowering scientists and researchers to drive progress in science and industry.

Contact

Address: 3281 E Guasti Rd
Ontario, CA 91761, United States
Phone: (601) 213-4426
Email: info@benchchem.com

[Contact our Ph.D. Support Team for a compatibility check](#)