

Application Note: In Vitro Cytotoxicity Assay Protocols for 5-Hexadecyl Methotrexate

Author: BenchChem Technical Support Team. **Date:** April 2026

Compound of Interest

Compound Name: 5-Hexadecyl methotrexate

CAS No.: 88887-42-7

Cat. No.: B1664181

[Get Quote](#)

Target Audience: Researchers, Scientists, and Drug Development Professionals
Document Type: Advanced Methodology & Protocol Guide

Introduction & Mechanistic Rationale

Methotrexate (MTX) is a foundational antifolate chemotherapeutic that competitively inhibits dihydrofolate reductase (DHFR), thereby halting de novo purine and pyrimidine synthesis. However, its clinical efficacy is severely bottlenecked by acquired cellular resistance. The most common mechanism of MTX resistance is the downregulation or mutation of the Reduced Folate Carrier (RFC), the primary active transport channel required for MTX internalization[1].

To overcome this transport-mediated resistance, lipophilic analogues such as **5-hexadecyl methotrexate** (also known as Hexadecyl-MTX or MTX

-hexadecyl ester) have been engineered[2]. By esterifying the

-carboxylic acid of the glutamate moiety with a 16-carbon alkyl chain, the molecule's lipophilicity is drastically increased (computed XLogP3

5.9) without disrupting its binding affinity to the DHFR active site[2][3].

The Causality of the Design: This structural modification acts as a molecular "skeleton key." The extreme lipophilicity allows 5-hexadecyl MTX to bypass the defective RFC entirely. Instead, it enters the cell via passive membrane diffusion or enables seamless incorporation into lipid-based nanocarriers (e.g., liposomes, solid lipid nanoparticles, or lipid nanoemulsions) for endocytotic uptake[3][4].

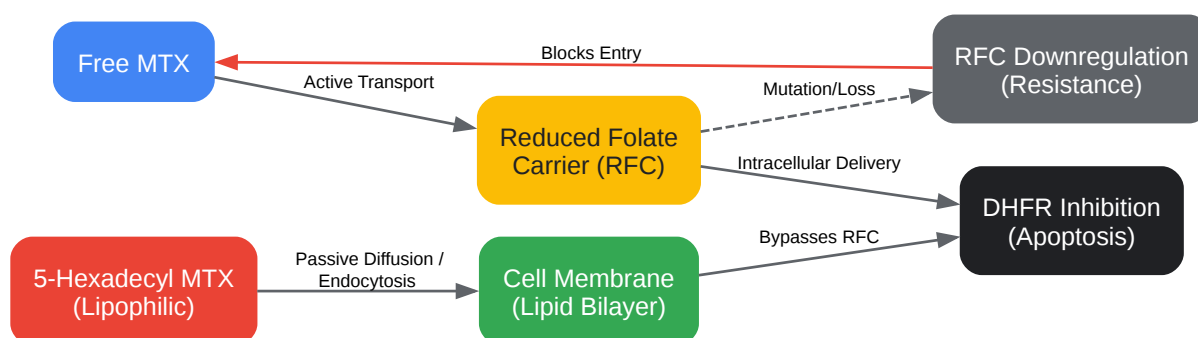

[Click to download full resolution via product page](#)

Figure 1: Mechanistic pathway of 5-Hexadecyl MTX bypassing RFC-mediated resistance to inhibit DHFR.

Experimental Design & Self-Validating Systems

Evaluating highly lipophilic compounds requires rigorous experimental architecture to prevent artifactual data. As an application scientist, you must build a self-validating system into your assay:

- **Solvent Causality & Micelle Prevention:** Because 5-hexadecyl MTX is virtually insoluble in aqueous media, standard serial dilutions in culture media will cause the drug to precipitate or form uncontrolled micelles, leading to erratic cytotoxicity data. Rule of thumb: Perform all serial dilutions in 100% DMSO first, then perform a single 1:200 dilution into culture media to ensure the final DMSO concentration remains

(v/v).

- Paired Cell Line Validation: To prove that cytotoxicity is driven by RFC-bypass rather than off-target lipotoxicity, assays must run concurrently on an MTX-sensitive line (e.g., MCF-7 or HL60) and an RFC-deficient/MTX-resistant line (e.g., MDA-MB-231 or K562)[1][4][5].
- Proliferation Dependency: MTX is strictly S-phase specific. Cells must be seeded at an optimized, low density to ensure they remain in the logarithmic growth phase throughout the entire 72-hour exposure. If cells reach confluence, proliferation arrests, and the drug will falsely appear inactive.

Quantitative Data Summary

The table below summarizes expected shift profiles when transitioning from free MTX to lipophilic MTX analogues across sensitive and resistant cell lines, demonstrating the restoration of cytotoxic efficacy[1][3][4].

Cell Line	Cancer Type	Resistance Status	Free MTX IC ₅₀ (μM)	Lipophilic MTX IC ₅₀ (μM)	Efficacy Shift
HL60	Leukemia	Sensitive	~26.0	~0.2	130x Improvement
K562	Leukemia	Resistant (Transport)	~18.2	~1.6	11x Improvement
KATO III	Gastric	Sensitive	~0.06	~0.055	Equivalent
MDA-MB-231	Breast	Resistant (Transport)	~18.5	~3.8	4.8x Improvement

Experimental Workflows & Protocols

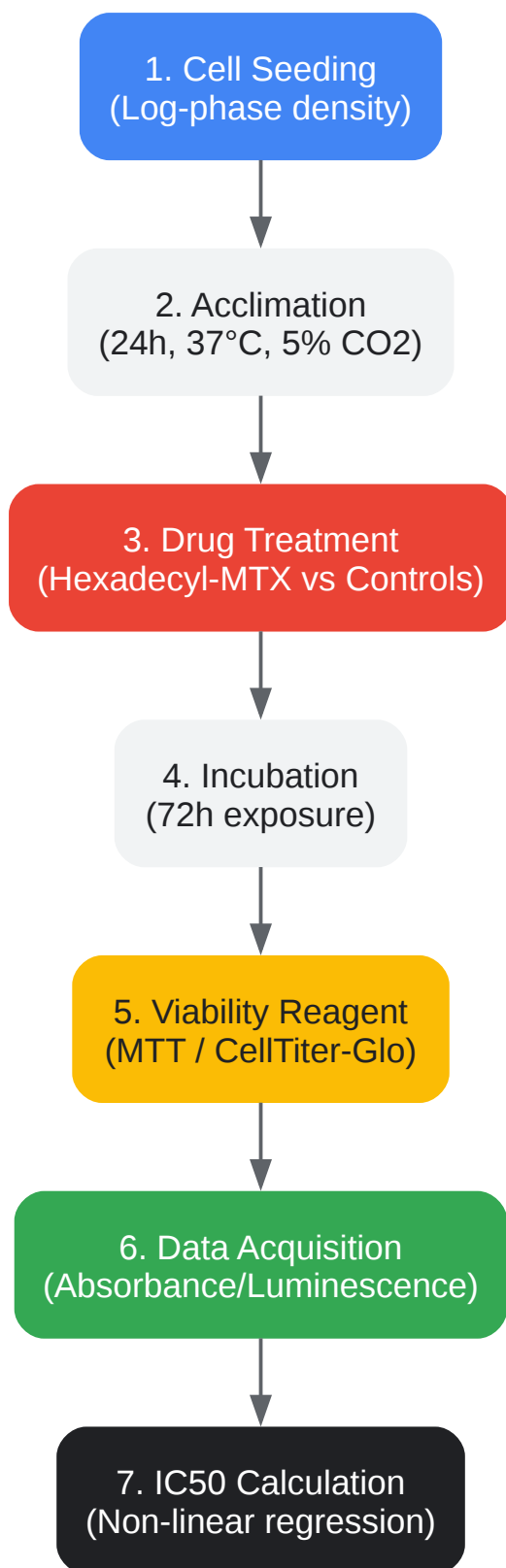

[Click to download full resolution via product page](#)

Figure 2: Step-by-step experimental workflow for high-throughput in vitro cytotoxicity assays.

Protocol A: Preparation of 5-Hexadecyl MTX Working Solutions

Note: This protocol assumes the use of free 5-hexadecyl MTX powder. If utilizing lipid nanocarriers, follow specific lipid-film hydration protocols^[5].

- **Stock Preparation:** Reconstitute 5-hexadecyl MTX powder in sterile, anhydrous DMSO to create a 10 mM master stock. Aliquot into amber tubes to prevent photodegradation and store at -20°C.
- **Serial Dilution:** Prepare a 200X concentration series in 100% DMSO. For example, to achieve a final well concentration of 10 µM, prepare a 2 mM intermediate in DMSO.
- **Aqueous Introduction:** Immediately prior to cell treatment, dilute the 200X DMSO stocks 1:200 into pre-warmed complete culture media. Vortex vigorously. The final DMSO concentration is now 0.5%, which is generally non-toxic to most robust cancer cell lines.

Protocol B: High-Throughput Cell Viability Assay (MTT)

Causality Check: While MTT measures mitochondrial oxidoreductase activity, it is a reliable proxy for cell number in DHFR-inhibited cells, provided the lipid vehicle itself does not uncouple mitochondrial metabolism.

- **Seeding:** Harvest cells in the exponential growth phase. Seed cells/well in 100 µL of complete media into a 96-well flat-bottom tissue culture plate.
 - **Self-Validating Control:** Leave column 1 as a "Media Only" blank to subtract background absorbance.
- **Acclimation:** Incubate plates for 24 hours at 37°C, 5% CO₂ to allow for cell attachment and recovery.
- **Treatment:** Aspirate the seeding media. Add 100 µL of the prepared 5-hexadecyl MTX working solutions (from Protocol A) to the designated wells.
 - **Self-Validating Control:** Include a "Vehicle Control" (0.5% DMSO in media) and a "Positive Control" (Free MTX).

- **Incubation:** Incubate for 72 hours. A 72-hour window ensures cells pass through at least two replication cycles, maximizing the S-phase specific toxicity of the antifolate.
- **Reagent Addition:** Add 20 μ L of MTT solution (5 mg/mL in PBS) to each well. Incubate for 3 to 4 hours at 37°C until purple formazan crystals are visible under a microscope.
- **Solubilization:** Carefully aspirate the media (avoiding the crystal pellet) and add 150 μ L of DMSO to each well. Agitate on an orbital shaker for 15 minutes protected from light.
- **Data Acquisition:** Read the absorbance at 570 nm using a microplate reader. Calculate viability relative to the vehicle control and determine the IC₅₀ using non-linear regression analysis.

Protocol C: Orthogonal Validation via Annexin V/PI Flow Cytometry

Causality Check: High concentrations of lipophilic drugs or their carrier solvents can cause rapid membrane lysis (necrosis). Annexin V/PI staining is mandatory to confirm that the reduction in viability is due to true DHFR-mediated programmed cell death (apoptosis).

- **Treatment & Harvest:** Following a 48-hour treatment in a 6-well plate, collect both the culture media (containing floating apoptotic cells) and the adherent cells (via trypsinization). Pool them together to ensure late-apoptotic cells are not lost.
- **Washing:** Centrifuge at 300 x g for 5 minutes. Wash the pellet twice with ice-cold PBS.
- **Staining:** Resuspend the cell pellet in 100 μ L of 1X Annexin V Binding Buffer. Add 5 μ L of FITC-Annexin V and 5 μ L of Propidium Iodide (PI).
- **Incubation:** Incubate for 15 minutes at room temperature in the dark.
- **Acquisition:** Add 400 μ L of 1X Binding Buffer and analyze immediately via flow cytometry.
 - **Interpretation:** Cells in the lower-right quadrant (Annexin V+ / PI-) represent early apoptosis, confirming the targeted antifolate mechanism of 5-hexadecyl MTX.

References[5] Title: Design and Characterization of Liposomal Methotrexate and Its Effect on BT-474 Breast Cancer Cell Line

Source: PubMed Central (NIH) URL:[Link][2] Title: **5-Hexadecyl methotrexate** | C36H54N8O5 | CID 145947 Source: PubChem (NIH) URL:[Link][3] Title: Liposomes containing alkylated methotrexate analogues for phospholipase A(2) mediated tumor targeted drug delivery Source: PubMed (NIH) URL: [Link][1] Title: Overcoming methotrexate resistance in breast cancer Source: Biochemical Pharmacology (Ovid/PubMed) URL:[Link][4] Title: Novel formulation of a methotrexate derivative with a lipid nanoemulsion Source: PubMed Central (NIH) URL:[Link]

Need Custom Synthesis?

BenchChem offers custom synthesis for rare earth carbides and specific isotopic labeling.

Email: info@benchchem.com or [Request Quote Online](#).

Sources

- 1. [ovid.com](https://www.ovid.com) [ovid.com]
- 2. [5-Hexadecyl methotrexate | C36H54N8O5 | CID 145947 - PubChem](https://pubchem.ncbi.nlm.nih.gov/compound/5-Hexadecyl%20methotrexate) [pubchem.ncbi.nlm.nih.gov]
- 3. [Liposomes containing alkylated methotrexate analogues for phospholipase A\(2\) mediated tumor targeted drug delivery - PubMed](https://pubmed.ncbi.nlm.nih.gov/28111111/) [pubmed.ncbi.nlm.nih.gov]
- 4. [Novel formulation of a methotrexate derivative with a lipid nanoemulsion - PMC](https://pubmed.ncbi.nlm.nih.gov/28111111/) [pmc.ncbi.nlm.nih.gov]
- 5. [Design and Characterization of Liposomal Methotrexate and Its Effect on BT-474 Breast Cancer Cell Line - PMC](https://pubmed.ncbi.nlm.nih.gov/28111111/) [pmc.ncbi.nlm.nih.gov]
- To cite this document: BenchChem. [Application Note: In Vitro Cytotoxicity Assay Protocols for 5-Hexadecyl Methotrexate]. BenchChem, [2026]. [Online PDF]. Available at: [\[https://www.benchchem.com/product/b1664181/docs#application-note-in-vitro-cytotoxicity-assay-protocols-for-5-hexadecyl-methotrexate\]](https://www.benchchem.com/product/b1664181/docs#application-note-in-vitro-cytotoxicity-assay-protocols-for-5-hexadecyl-methotrexate)

Disclaimer & Data Validity:

The information provided in this document is for Research Use Only (RUO) and is strictly not intended for diagnostic or therapeutic procedures. While BenchChem strives to provide accurate protocols, we make no warranties, express or implied, regarding the fitness of this product for every specific experimental setup.

Technical Support: The protocols provided are for reference purposes. Unsure if this reagent suits your experiment?

Need Industrial/Bulk Grade? [Request Custom Synthesis Quote](#)

BenchChem

Our mission is to be the trusted global source of essential and advanced chemicals, empowering scientists and researchers to drive progress in science and industry.

Contact

Address: 3281 E Guasti Rd
Ontario, CA 91761, United States
Phone: (601) 213-4426
Email: info@benchchem.com

[Contact our Ph.D. Support Team for a compatibility check](#)