

# A 779 lot-to-lot variability and its impact.

**Author:** BenchChem Technical Support Team. **Date:** December 2025

## Compound of Interest

Compound Name: A 779

Cat. No.: B1664258

[Get Quote](#)

## Technical Support Center: A-779

This technical support center provides troubleshooting guidance and frequently asked questions (FAQs) for researchers, scientists, and drug development professionals working with the Mas receptor antagonist, A-779. Lot-to-lot variability of peptide reagents can be a significant source of experimental inconsistency, and this resource is designed to help you identify and address potential issues.

## Frequently Asked Questions (FAQs)

Q1: What is A-779 and what is its primary mechanism of action?

A-779 is a selective antagonist for the Mas receptor, a key component of the protective arm of the renin-angiotensin system (RAS). Its primary function is to block the binding of the endogenous ligand Angiotensin-(1-7) [Ang-(1-7)] to the Mas receptor. This action inhibits the downstream signaling pathways typically activated by Ang-(1-7), which are often associated with vasodilation, anti-inflammatory, and anti-proliferative effects.

Q2: What are the common applications of A-779 in research?

A-779 is widely used to investigate the physiological and pathophysiological roles of the Ang-(1-7)/Mas receptor axis. Common applications include studying its effects on cardiovascular regulation, inflammation, fibrosis, and cellular growth. By blocking the Mas receptor, researchers can elucidate the specific contributions of this pathway in various biological processes and disease models.

Q3: How should I properly store and handle A-779?

Lyophilized A-779 should be stored at -20°C or -80°C. Once reconstituted, it is recommended to aliquot the solution and store it at -80°C to minimize freeze-thaw cycles. For reconstitution, use a solvent appropriate for your experimental system, such as sterile water or a buffer solution. Always refer to the manufacturer's instructions for specific solubility information.

## Troubleshooting Guide: A-779 Lot-to-Lot Variability

Inconsistent or unexpected experimental results when using A-779 can often be attributed to lot-to-lot variability. This guide provides a structured approach to troubleshooting these issues.

Q4: My current lot of A-779 is showing a different level of inhibition compared to a previous lot. What could be the cause?

This is a classic sign of lot-to-lot variability. The observed difference in inhibitory activity can stem from several factors, including variations in peptide purity, the presence of different counter-ions from the synthesis process, or incorrect peptide concentration.

Recommended Actions:

- **Review the Certificate of Analysis (CoA):** Compare the CoAs for both the new and old lots of A-779. Pay close attention to the reported purity (typically determined by HPLC) and the net peptide content.
- **Perform a Dose-Response Curve:** To empirically determine the potency of the new lot, perform a dose-response experiment to calculate its IC<sub>50</sub> (half-maximal inhibitory concentration) in your specific assay. This will allow you to adjust the concentration of the new lot to match the activity of the previous one.
- **Validate with a Functional Assay:** Use a well-established functional assay to confirm the activity of the new lot. For example, you can measure the ability of A-779 to block Ang-(1-7)-induced signaling, such as the inhibition of NF-κB activation.[1]

Q5: I am observing unexpected or off-target effects with a new batch of A-779. How can I troubleshoot this?

Off-target effects can be caused by impurities or by the peptide itself at high concentrations.

#### Recommended Actions:

- **Assess Purity:** If not already done, review the purity data on the CoA. If the purity is lower than expected, or if you suspect the presence of contaminating peptides, consider having the peptide's purity and identity confirmed by an independent analysis (e.g., HPLC and mass spectrometry).
- **Titrate the Concentration:** Determine the lowest effective concentration of A-779 in your experiments to minimize the risk of off-target effects.
- **Include Appropriate Controls:** Ensure your experiments include controls to account for any non-specific effects of the peptide or its vehicle.

## Data Presentation: Illustrative Impact of Variability on IC50

While specific data on A-779 lot-to-lot variability is not readily available in public literature, the following table illustrates how IC50 values for a different compound, TAK-779, can vary. This highlights the importance of validating each new lot of a reagent. The data shows a range of historical IC50 values for TAK-779 in a CCR5-tropic viral entry assay.<sup>[2]</sup>

Parameter	Value
Number of Lots Tested	111
Mean IC50	Not explicitly stated
Standard Deviations from the Mean	The majority of values fall within two standard deviations
Outliers	One outlier was identified

This table is for illustrative purposes to demonstrate the concept of lot-to-lot variability and does not represent actual data for A-779.

## Experimental Protocols

Protocol: In Vitro Validation of A-779 Activity via Inhibition of Ang-(1-7)-Induced NF- $\kappa$ B Activation

This protocol describes a cell-based assay to confirm the inhibitory activity of a new lot of A-779.

### 1. Cell Culture and Treatment:

- Culture human aortic smooth muscle cells (HASMCs) in appropriate media.[\[3\]](#)
- Seed cells in 6-well plates and grow to 80-90% confluency.
- Pre-incubate the cells with the new lot of A-779 (e.g., at a concentration of 1  $\mu$ M) for 1 hour.  
[\[3\]](#)
- Stimulate the cells with Ang-(1-7) (e.g., 100 nM) for 18 hours.[\[3\]](#)
- Include control groups: untreated cells, cells treated with Ang-(1-7) only, and cells treated with A-779 only.

### 2. Nuclear Protein Extraction:

- After treatment, wash the cells with ice-cold PBS.
- Lyse the cells and extract nuclear proteins using a commercial nuclear extraction kit according to the manufacturer's instructions.
- Determine the protein concentration of the nuclear extracts using a BCA or Bradford assay.

### 3. Electrophoretic Mobility Shift Assay (EMSA):

- Use an EMSA kit to assess NF- $\kappa$ B DNA binding activity.
- Incubate nuclear extracts with a biotin-labeled NF- $\kappa$ B consensus oligonucleotide.
- Separate the protein-DNA complexes by non-denaturing polyacrylamide gel electrophoresis.

- Transfer the complexes to a nylon membrane.
- Detect the biotin-labeled DNA using a streptavidin-horseradish peroxidase conjugate and a chemiluminescent substrate.
- Image the membrane to visualize the bands corresponding to the NF- $\kappa$ B-DNA complexes.

#### 4. Data Analysis:

- Quantify the band intensities using densitometry software.
- Compare the NF- $\kappa$ B activation in the Ang-(1-7) treated group with the group pre-treated with A-779. A significant reduction in the band intensity in the A-779 treated group confirms its inhibitory activity.

## Mandatory Visualizations

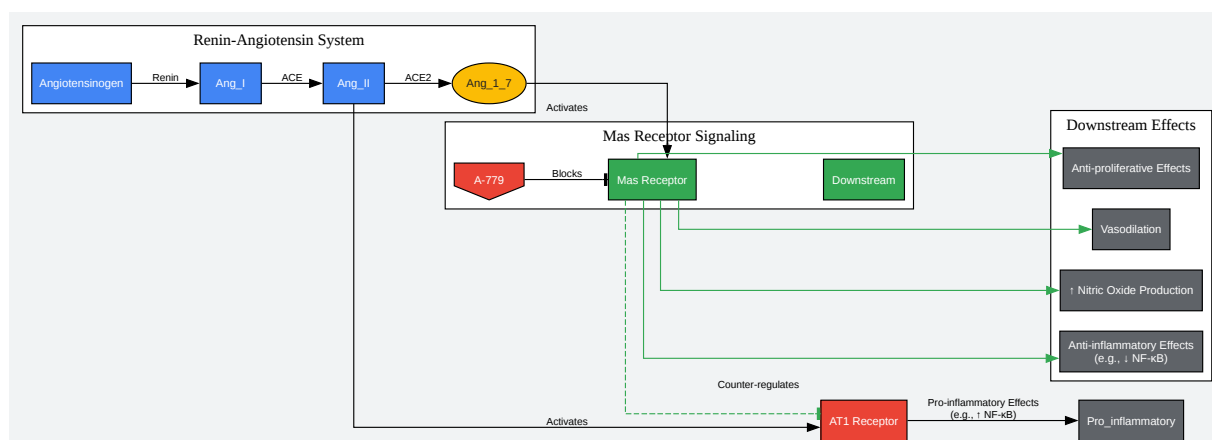

[Click to download full resolution via product page](#)

Caption: Ang-(1-7)/Mas Receptor Signaling Pathway and A-779 Inhibition.

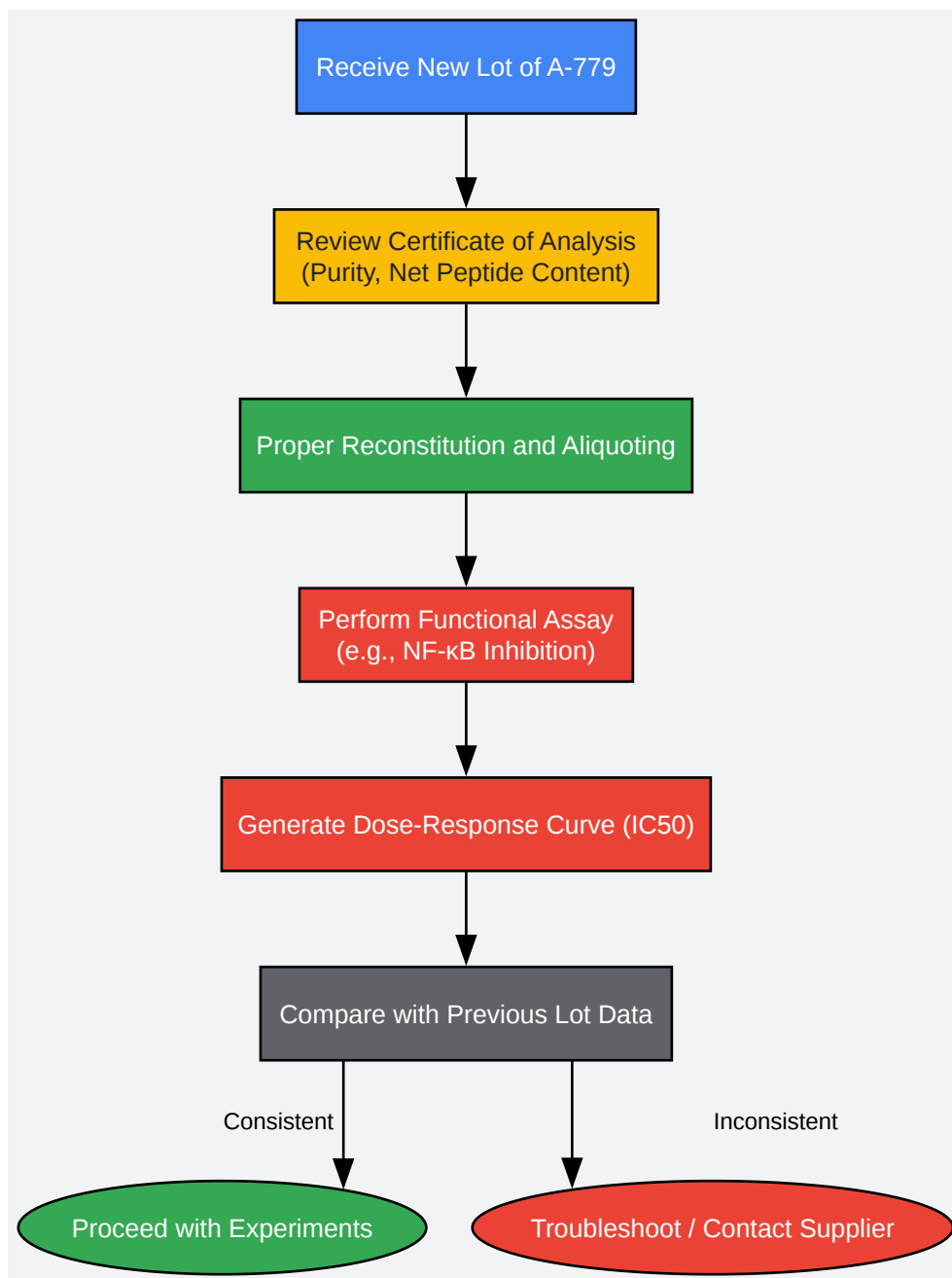

[Click to download full resolution via product page](#)

Caption: Recommended Workflow for A-779 Lot Validation.

### ***Need Custom Synthesis?***

*BenchChem offers custom synthesis for rare earth carbides and specific isotopic labeling.*

*Email: [info@benchchem.com](mailto:info@benchchem.com) or [Request Quote Online](#).*

## References

- 1. mdpi.com [mdpi.com]
- 2. researchgate.net [researchgate.net]
- 3. Frontiers | The Angiotensin-(1-7)/Mas Axis Counteracts Angiotensin II-Dependent and -Independent Pro-inflammatory Signaling in Human Vascular Smooth Muscle Cells [frontiersin.org]
- To cite this document: BenchChem. [A 779 lot-to-lot variability and its impact.]. BenchChem, [2025]. [Online PDF]. Available at: [https://www.benchchem.com/product/b1664258#a-779-lot-to-lot-variability-and-its-impact]

---

### Disclaimer & Data Validity:

The information provided in this document is for Research Use Only (RUO) and is strictly not intended for diagnostic or therapeutic procedures. While BenchChem strives to provide accurate protocols, we make no warranties, express or implied, regarding the fitness of this product for every specific experimental setup.

**Technical Support:** The protocols provided are for reference purposes. Unsure if this reagent suits your experiment? [[Contact our Ph.D. Support Team for a compatibility check](#)]

**Need Industrial/Bulk Grade?** [Request Custom Synthesis Quote](#)

## BenchChem

Our mission is to be the trusted global source of essential and advanced chemicals, empowering scientists and researchers to drive progress in science and industry.

### Contact

Address: 3281 E Guasti Rd

Ontario, CA 91761, United States

Phone: (601) 213-4426

Email: [info@benchchem.com](mailto:info@benchchem.com)