

Technical Support Center: Minimizing Off-Target Effects of BIM 23052

Author: BenchChem Technical Support Team. **Date:** April 2026

Compound of Interest

Compound Name: BIM 23052
CAS No.: 133073-82-2
Cat. No.: B1663766

[Get Quote](#)

Welcome to the technical support center for **BIM 23052**. This resource is designed for researchers, scientists, and drug development professionals to provide guidance on the effective use of **BIM 23052** while minimizing its off-target effects. Here you will find troubleshooting guides, frequently asked questions (FAQs), detailed experimental protocols, and supporting data to ensure the accuracy and reproducibility of your research.

I. Troubleshooting Guides

Unexpected results can arise from a variety of factors, from experimental setup to the inherent properties of the compound. This guide addresses common issues encountered when using **BIM 23052**.

Table 1: Troubleshooting Common Issues with **BIM 23052**

Problem	Potential Cause	Recommended Solution
No or weak response to BIM 23052	<ol style="list-style-type: none">1. Low or no expression of somatostatin receptor 5 (sst5) in the cell line.2. Incorrect concentration of BIM 23052 used.3. Degradation of BIM 23052.4. Suboptimal assay conditions.	<ol style="list-style-type: none">1. Verify sst5 expression in your cell line using qPCR, Western blot, or flow cytometry. Consider using a cell line known to express sst5, such as CHO-K1 cells stably transfected with the human sst5 receptor.2. Perform a dose-response curve to determine the optimal concentration. Start with a range from 1 nM to 1 μM. The reported K_i for sst5 is 7.3 nM. [1][2][3]3. Prepare fresh stock solutions of BIM 23052 in sterile water at 1 mg/mL. [1] Aliquot and store at -20°C to avoid repeated freeze-thaw cycles. Ensure the compound is fully dissolved.4. Optimize assay parameters such as cell density, incubation time, and buffer components.
High background signal or unexpected cellular effects	<ol style="list-style-type: none">1. Off-target effects due to binding to other somatostatin receptors (sst1, sst2, sst4).2. Cytotoxicity at high concentrations.3. Non-specific binding to other cellular components.	<ol style="list-style-type: none">1. Use the lowest effective concentration of BIM 23052 determined from your dose-response curve. - Employ specific antagonists for sst1, sst2, and sst4 as negative controls to confirm that the observed effect is sst5-mediated. - Use a panel of cell lines with varying expression levels of somatostatin receptor subtypes to dissect the specific

contribution of sst5 activation.² Assess cell viability using an MTT or similar assay in parallel with your functional experiments. While BIM 23052 itself has limited published cytotoxicity data, its analogs have shown cytotoxic effects at higher concentrations.^{[4][5]}³ Include appropriate vehicle controls in all experiments.

Inconsistent results between experiments

1. Variability in cell passage number and health.²
Inconsistent preparation of BIM 23052 solutions.³
Differences in experimental timing and conditions.

1. Use cells within a consistent and low passage number range. Regularly check for mycoplasma contamination.² Always prepare fresh dilutions from a single, validated stock aliquot for each experiment.³ Standardize all experimental steps, including incubation times, temperatures, and reagent concentrations.

II. Frequently Asked Questions (FAQs)

Q1: What is the primary mechanism of action of **BIM 23052**?

A1: **BIM 23052** is a selective agonist for the somatostatin receptor 5 (sst5).^{[1][6]} Sst5 is a G-protein coupled receptor (GPCR) that, upon activation, typically couples to inhibitory G proteins (Gi/o). This leads to the inhibition of adenylyl cyclase, resulting in a decrease in intracellular cyclic AMP (cAMP) levels.

Q2: What are the known off-target receptors for **BIM 23052**?

A2: **BIM 23052** exhibits binding affinity for other somatostatin receptor subtypes, which can be considered off-target interactions. The binding affinities (K_i) are summarized in the table below.

Table 2: Binding Affinity of **BIM 23052** for Somatostatin Receptor Subtypes

Receptor Subtype	Binding Affinity (K _i) in nM
sst5 (On-Target)	7.3
sst2 (Off-Target)	13.5
sst1 (Off-Target)	31.3
sst4 (Off-Target)	141

Data sourced from multiple suppliers and publications.[\[1\]](#)[\[2\]](#)[\[3\]](#)

Q3: How can I experimentally distinguish between on-target (sst5) and off-target effects?

A3: To isolate the effects of sst5 activation, you can employ several strategies:

- Use of Selective Antagonists: Co-incubate your cells with **BIM 23052** and a selective antagonist for the suspected off-target receptor (e.g., an sst2 antagonist). If the off-target effect is diminished while the primary response is maintained, it suggests the involvement of that receptor.
- RNA Interference (RNAi): Use siRNA or shRNA to specifically knock down the expression of off-target receptors (sst1, sst2, sst4) in your cell model.
- Receptor Expression Profiling: Characterize the relative expression levels of all somatostatin receptor subtypes in your experimental system. This will help you anticipate potential off-target liabilities. Pituitary adenoma and gastroenteropancreatic neuroendocrine tumors are known to express varying levels of different sst subtypes.[\[7\]](#)

Q4: What is the recommended solvent and storage condition for **BIM 23052**?

A4: **BIM 23052** is soluble in water up to 1 mg/mL.[\[1\]](#) It is recommended to prepare a stock solution, aliquot it, and store it at -20°C for long-term use. For short-term storage, -20°C is also

appropriate.[3] Avoid repeated freeze-thaw cycles.

Q5: Are there any known issues with the stability of **BIM 23052** in cell culture media?

A5: While specific stability data for **BIM 23052** in various culture media is not extensively published, it is a peptide-based compound. As with most peptides, prolonged incubation at 37°C can lead to degradation. It is advisable to prepare fresh dilutions in media for each experiment and minimize the pre-incubation time where possible.

III. Experimental Protocols

A. General Cell Culture and Handling

- **Cell Lines:** CHO-K1 or HEK293 cells stably expressing the human sst5 receptor are recommended for initial characterization and to minimize confounding effects from other endogenously expressed receptors. For disease-relevant models, cell lines such as pituitary adenoma cells or pancreatic cancer cell lines (e.g., BON-1, which expresses multiple sst subtypes) can be used, but require careful characterization of receptor expression.
- **Culture Conditions:** Culture cells in the appropriate medium supplemented with fetal bovine serum (FBS) and antibiotics. Maintain cells in a humidified incubator at 37°C with 5% CO₂.
- **Cell Plating:** For most assays, seed cells in 96-well plates at a density that allows them to reach 80-90% confluency on the day of the experiment.

B. cAMP Inhibition Assay Protocol

This protocol is designed to measure the inhibition of adenylyl cyclase activity through the activation of sst5 by **BIM 23052**.

Materials:

- sst5-expressing cells (e.g., CHO-sst5)
- **BIM 23052**
- Forskolin
- IBMX (a phosphodiesterase inhibitor)

- cAMP assay kit (e.g., HTRF, ELISA, or fluorescence-based)
- Assay buffer (e.g., HBSS with 20 mM HEPES)

Procedure:

- Cell Plating: Seed cells in a 96-well plate and grow overnight.
- Cell Starvation: On the day of the assay, remove the growth medium and replace it with serum-free medium for 2-4 hours.
- Compound Preparation: Prepare a serial dilution of **BIM 23052** in assay buffer. A typical concentration range would be 10^{-11} M to 10^{-6} M.
- Pre-incubation: Add IBMX to all wells to a final concentration of 100 μ M and incubate for 10-15 minutes at 37°C.
- Agonist Stimulation: Add the **BIM 23052** dilutions to the respective wells and incubate for 15-30 minutes at 37°C.
- Adenylyl Cyclase Activation: Add forskolin to all wells (except for the basal control) to a final concentration that elicits a submaximal cAMP response (typically 1-10 μ M, to be optimized for your cell line). Incubate for 15-30 minutes at 37°C.
- Cell Lysis and cAMP Measurement: Lyse the cells and measure the intracellular cAMP levels according to the manufacturer's instructions of your chosen cAMP assay kit.
- Data Analysis: Plot the cAMP concentration against the log of the **BIM 23052** concentration and fit the data to a sigmoidal dose-response curve to determine the EC50.

C. Experimental Workflow for Minimizing Off-Target Effects

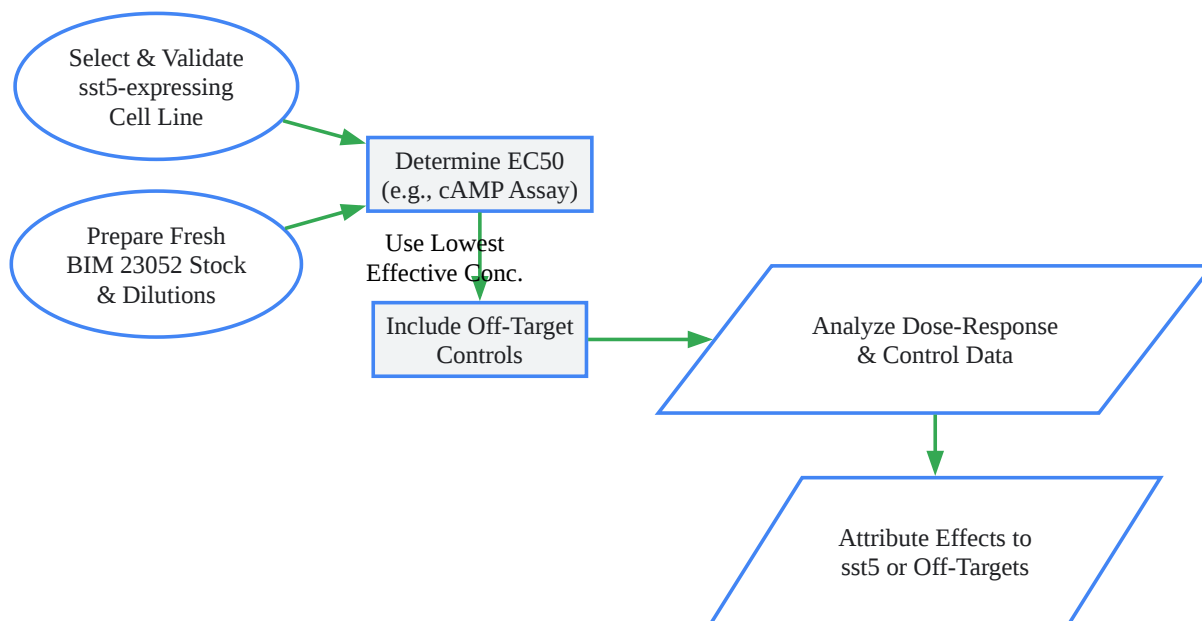

[Click to download full resolution via product page](#)

Caption: Workflow for designing experiments with **BIM 23052** to minimize off-target effects.

IV. Signaling Pathways and Visualizations

A. Sst5 Signaling Pathway

Upon binding of **BIM 23052**, sst5 undergoes a conformational change, leading to the activation of associated inhibitory G-proteins. This initiates a signaling cascade that primarily involves the inhibition of adenylyl cyclase and a subsequent decrease in intracellular cAMP levels.

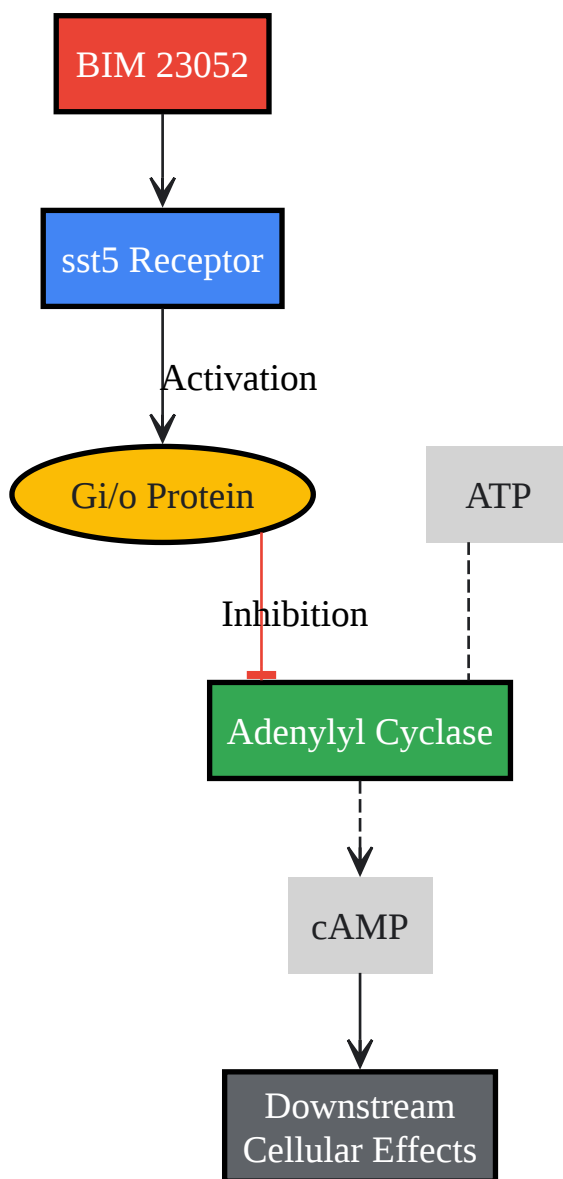

[Click to download full resolution via product page](#)

Caption: Simplified signaling pathway of the sst5 receptor upon activation by **BIM 23052**.

B. Logical Relationship for Troubleshooting High Background Signal

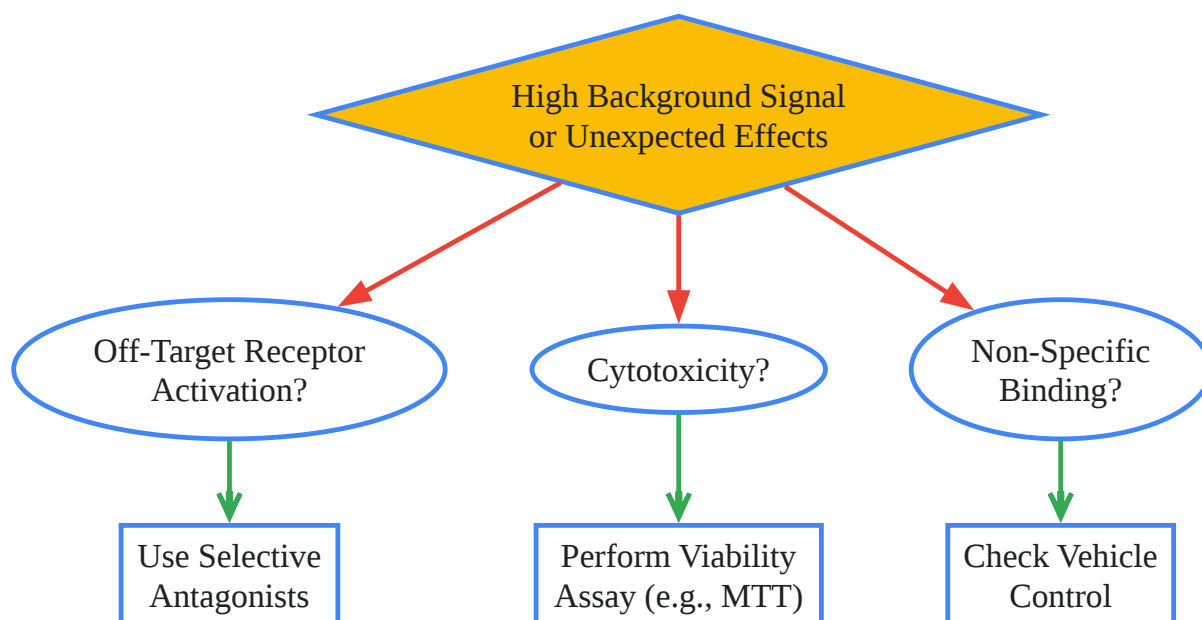

[Click to download full resolution via product page](#)

Caption: Decision tree for troubleshooting high background signals in **BIM 23052** experiments.

Need Custom Synthesis?

BenchChem offers custom synthesis for rare earth carbides and specific isotopic labeling.

Email: info@benchchem.com or [Request Quote Online](#).

References

- [1. BIM 23052 \(CAS 133073-82-2\): R&D Systems \[rndsystems.com\]](#)
- [2. BIM 23052 | CAS 133073-82-2 | Tocris Bioscience \[tocris.com\]](#)
- [3. BIM 23052, Somatostatin \(sst5\) receptor 5 agonist \(CAS 133073-82-2\) | Abcam \[abcam.com\]](#)
- [4. researchgate.net \[researchgate.net\]](#)
- [5. researchgate.net \[researchgate.net\]](#)
- [6. medchemexpress.com \[medchemexpress.com\]](#)

- 7. Somatostatin receptor subtypes sst1, sst2, sst3 and sst5 expression in human pituitary, gastroentero-pancreatic and mammary tumors: comparison of mRNA analysis with receptor autoradiography - PubMed [pubmed.ncbi.nlm.nih.gov]
- To cite this document: BenchChem. [Technical Support Center: Minimizing Off-Target Effects of BIM 23052]. BenchChem, [2026]. [Online PDF]. Available at: [https://www.benchchem.com/product/b1663766/docs#technical-support-center-minimizing-off-target-effects-of-bim-23052]

Disclaimer & Data Validity:

The information provided in this document is for Research Use Only (RUO) and is strictly not intended for diagnostic or therapeutic procedures. While BenchChem strives to provide accurate protocols, we make no warranties, express or implied, regarding the fitness of this product for every specific experimental setup.

Technical Support: The protocols provided are for reference purposes. Unsure if this reagent suits your experiment?

Need Industrial/Bulk Grade? [Request Custom Synthesis Quote](#)

BenchChem

Our mission is to be the trusted global source of essential and advanced chemicals, empowering scientists and researchers to drive progress in science and industry.

Contact

Address: 3281 E Guasti Rd
Ontario, CA 91761, United States
Phone: (601) 213-4426
Email: info@benchchem.com

[Contact our Ph.D. Support Team for a compatibility check](#)

