

Application Notes and Protocols for the Iodination of Benzoic Acid Derivatives

Author: BenchChem Technical Support Team. **Date:** April 2026

Compound of Interest

Compound Name: HTBA
CAS No.: 53279-72-4
Cat. No.: B1663327

[Get Quote](#)

For Researchers, Scientists, and Drug Development Professionals

This document provides detailed methodologies for the iodination of benzoic acid derivatives, crucial intermediates in the synthesis of pharmaceuticals and other functional organic molecules. The protocols outlined below cover a range of techniques, from classical diazotization reactions to modern catalytic methods, offering versatility for various substrates and research needs.

Introduction

Iodinated benzoic acid derivatives are valuable building blocks in organic synthesis, particularly in cross-coupling reactions such as Suzuki, Heck, and Sonogashira couplings, which are fundamental in drug discovery and materials science. The introduction of an iodine atom onto the aromatic ring of benzoic acid can be achieved through several synthetic strategies. The choice of method often depends on the desired regioselectivity, the nature of the substituents on the benzoic acid core, and the required reaction conditions. This document details three primary protocols for the iodination of benzoic acid derivatives and provides a comparative overview of their key quantitative parameters.

Comparative Data of Iodination Protocols

The following table summarizes the key quantitative data for the different iodination methods described in this document, allowing for easy comparison of their efficacy and applicability.

Method	Iodinating Agent(s)	Catalyst/Reagent	Typical Substrates	Typical Yields	Key Advantages
Diazotization (Sandmeyer Reaction)	Sodium Nitrite, Potassium Iodide	Hydrochloric Acid or Sulfuric Acid	Aminobenzoic acids	72-81%	Well-established, high-yielding for specific isomers.[1]
Electrophilic Iodination with NIS	N-Iodosuccinimide (NIS)	Trifluoroacetic Acid (TFA) or Sulfuric Acid (H ₂ SO ₄)	Deactivated and activated benzoic acid derivatives	Variable	Mild conditions, good for many deactivated systems.[2][3]
Iodination with Iodine & Oxidant	Iodine (I ₂)	Periodic Acid (H ₅ IO ₆) or Nitric Acid (HNO ₃)	Unactivated and deactivated aromatic compounds	Good	Uses readily available reagents, effective for poly-iodination.[4][5][6]
Iridium-Catalyzed C-H Activation	N-Iodosuccinimide (NIS)	Iridium Complex	Benzoic acids	High	High ortho-selectivity, mild reaction conditions.[7][8]

Experimental Protocols

Protocol 1: Synthesis of 2-Iodobenzoic Acid via Diazotization of Anthranilic Acid

This protocol describes the synthesis of 2-iodobenzoic acid from anthranilic acid using a Sandmeyer-type reaction involving diazotization followed by treatment with potassium iodide.

[9][10]

Materials:

- Anthranilic acid
- Sodium nitrite (NaNO_2)
- Hydrochloric acid (HCl), concentrated
- Potassium iodide (KI)
- Ice
- Deionized water
- Starch-iodide paper

Procedure:

- In a beaker, dissolve anthranilic acid in a solution of concentrated hydrochloric acid and water. Cool the mixture to 0-5 °C in an ice bath with constant stirring.
- In a separate beaker, prepare a solution of sodium nitrite in deionized water and cool it to 0-5 °C.
- Slowly add the cold sodium nitrite solution to the anthranilic acid solution. Maintain the temperature below 5 °C throughout the addition. The formation of the diazonium salt is indicated by a color change.
- Test for the presence of excess nitrous acid using starch-iodide paper (a blue-black color indicates excess).

- In a separate larger beaker, dissolve potassium iodide in water.
- Slowly and carefully add the cold diazonium salt solution to the potassium iodide solution with stirring. Vigorous nitrogen evolution will be observed.
- After the addition is complete, allow the mixture to stand for a short period and then gently warm it to complete the reaction.
- Cool the reaction mixture and collect the precipitated crude 2-iodobenzoic acid by vacuum filtration.
- Wash the crude product with cold water.
- Recrystallize the crude 2-iodobenzoic acid from hot water or ethanol to obtain the purified product.^[9]

Protocol 2: Iodination of Deactivated Benzoic Acid Derivatives using N-Iodosuccinimide (NIS) and Trifluoroacetic Acid (TFA)

This method is effective for the iodination of aromatic compounds that are deactivated towards electrophilic substitution.^{[2][11]}

Materials:

- Substituted benzoic acid
- N-Iodosuccinimide (NIS)
- Trifluoroacetic acid (TFA)
- Dichloromethane (DCM) or other suitable solvent
- Sodium thiosulfate solution (aqueous)
- Sodium bicarbonate solution (aqueous)
- Brine

- Anhydrous magnesium sulfate or sodium sulfate

Procedure:

- In a round-bottom flask, dissolve the substituted benzoic acid in the chosen solvent (e.g., DCM).
- Add N-Iodosuccinimide (1.0-1.2 equivalents) to the solution and stir.
- Carefully add trifluoroacetic acid (can be used as a co-solvent or in catalytic amounts depending on the substrate's reactivity) to the mixture.
- Stir the reaction mixture at room temperature. Monitor the progress of the reaction by thin-layer chromatography (TLC).
- Once the reaction is complete, quench the reaction by adding an aqueous solution of sodium thiosulfate to reduce any unreacted iodine.
- Transfer the mixture to a separatory funnel and wash sequentially with sodium bicarbonate solution and brine.
- Dry the organic layer over anhydrous magnesium sulfate or sodium sulfate.
- Filter the drying agent and concentrate the organic solvent under reduced pressure to obtain the crude product.
- Purify the product by recrystallization or column chromatography.

Protocol 3: Iodination of Benzoic Acid using Iodine and Periodic Acid

This protocol utilizes iodine in the presence of an oxidizing agent, periodic acid, to generate a potent electrophilic iodinating species.^[5]

Materials:

- Benzoic acid

- Iodine (I₂)
- Periodic acid dihydrate (H₅IO₆)
- Glacial acetic acid
- Sulfuric acid (H₂SO₄), concentrated
- Deionized water

Procedure:

- In a reaction flask, combine the benzoic acid, iodine, and periodic acid dihydrate in glacial acetic acid.
- Prepare a solution of concentrated sulfuric acid in water and add it to the reaction mixture.
- Heat the resulting solution with stirring. The disappearance of the purple color of iodine indicates the progress of the reaction.
- After the reaction is complete (as monitored by TLC), cool the mixture to room temperature and pour it into a beaker containing ice water to precipitate the product.
- Collect the solid product by vacuum filtration and wash it thoroughly with deionized water.
- The crude product can be further purified by recrystallization.

Visualizations

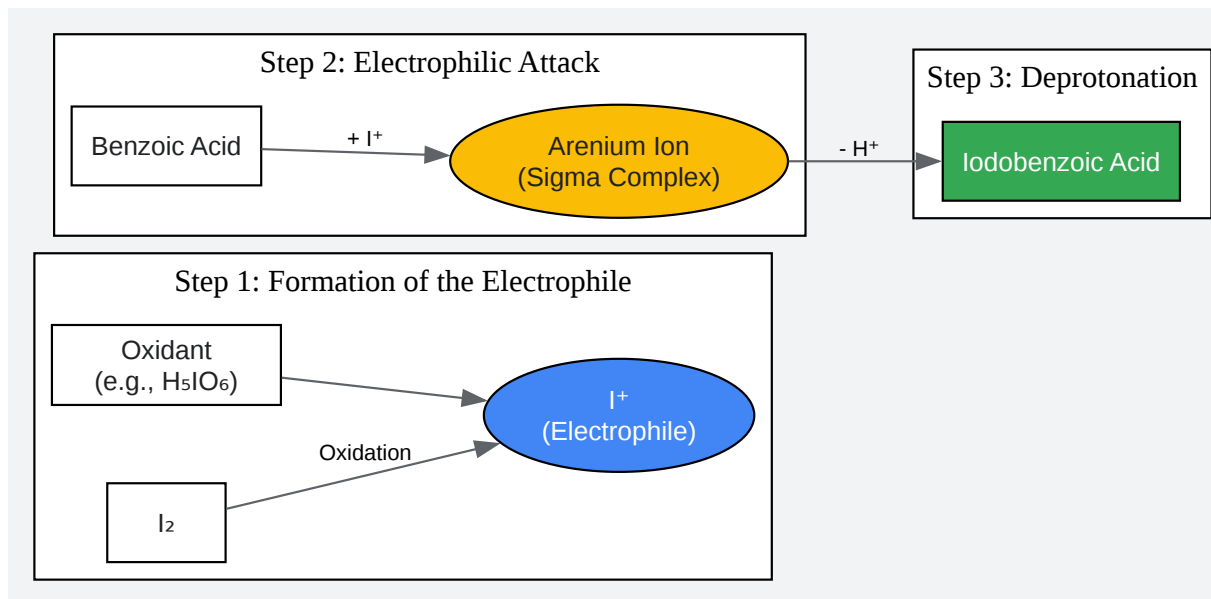

[Click to download full resolution via product page](#)

Caption: General mechanism of electrophilic aromatic iodination.

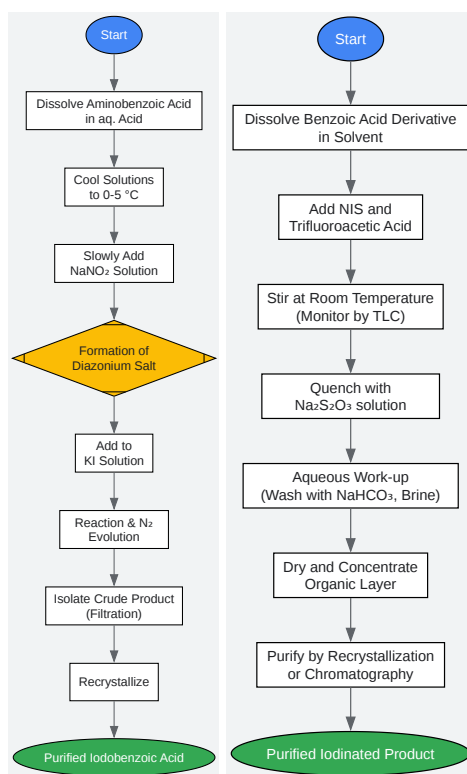

[Click to download full resolution via product page](#)

Need Custom Synthesis?

BenchChem offers custom synthesis for rare earth carbides and specific isotopic labeling.

Email: info@benchchem.com or [Request Quote Online](#).

References

- [1. Organic Syntheses Procedure \[orgsyn.org\]](#)
- [2. benchchem.com \[benchchem.com\]](#)
- [3. researchgate.net \[researchgate.net\]](#)
- [4. pubs.acs.org \[pubs.acs.org\]](#)
- [5. Organic Syntheses Procedure \[orgsyn.org\]](#)
- [6. Electrophilic halogenation - Wikipedia \[en.wikipedia.org\]](#)
- [7. pubs.acs.org \[pubs.acs.org\]](#)
- [8. IrIII -Catalyzed Selective ortho-Monoiodination of Benzoic Acids with Unbiased C-H Bonds - PubMed \[pubmed.ncbi.nlm.nih.gov\]](#)
- [9. What is the 2-Iodobenzoic acid?Uses,Synthesis,Purification Methods_Chemicalbook \[chemicalbook.com\]](#)
- [10. 2-Iodobenzoic acid - Wikipedia \[en.wikipedia.org\]](#)
- [11. benchchem.com \[benchchem.com\]](#)
- To cite this document: BenchChem. [Application Notes and Protocols for the Iodination of Benzoic Acid Derivatives]. BenchChem, [2026]. [Online PDF]. Available at: [\[https://www.benchchem.com/product/b1663327/docs#application-notes-and-protocols-for-the-iodination-of-benzoic-acid-derivatives\]](https://www.benchchem.com/product/b1663327/docs#application-notes-and-protocols-for-the-iodination-of-benzoic-acid-derivatives)

Disclaimer & Data Validity:

The information provided in this document is for Research Use Only (RUO) and is strictly not intended for diagnostic or therapeutic procedures. While BenchChem strives to provide

accurate protocols, we make no warranties, express or implied, regarding the fitness of this product for every specific experimental setup.

Technical Support: The protocols provided are for reference purposes. Unsure if this reagent suits your experiment?

Need Industrial/Bulk Grade? [Request Custom Synthesis Quote](#)

BenchChem

Our mission is to be the trusted global source of essential and advanced chemicals, empowering scientists and researchers to drive progress in science and industry.

Contact

Address: 3281 E Guasti Rd

Ontario, CA 91761, United States

Phone: (601) 213-4426

Email: info@benchchem.com

[Contact our Ph.D. Support Team for a compatibility check](#)