

A comparative study of 1H-Perfluorodecane and its deuterated analog

Author: BenchChem Technical Support Team. **Date:** May 2026

Compound of Interest

Compound Name: 1H-Perfluorodecane

CAS No.: 375-97-3

Cat. No.: B1663968

[Get Quote](#)

A Comparative Guide to **1H-Perfluorodecane** and its Deuterated Analog for Researchers and Drug Development Professionals

In the landscape of chemical tools available to researchers, fluorinated compounds hold a unique position due to their distinct properties. Among these, **1H-Perfluorodecane** is a significant molecule, utilized in applications ranging from surface chemistry to advanced medical imaging. The strategic replacement of its single proton with a deuterium atom creates its deuterated analog, a subtle yet powerful modification that unlocks a host of altered physicochemical properties and expanded applications. This guide provides an in-depth comparison of **1H-Perfluorodecane** and its deuterated form, offering insights into their respective advantages and the experimental methodologies used to characterize them.

Foundational Physicochemical Properties: A Tale of Two Isotopes

At a glance, **1H-Perfluorodecane** ($C_{10}HF_{21}$) and its deuterated counterpart ($C_{10}DF_{21}$) are structurally almost identical. However, the substitution of protium (1H) with deuterium (2H or D),

an isotope of hydrogen with an additional neutron, introduces measurable differences in their physical properties. This is primarily due to the increased mass of deuterium.

The C-D bond is slightly shorter and stronger than the C-H bond, a direct consequence of the lower zero-point energy of the C-D bond. This fundamental difference is the origin of the kinetic isotope effect, a phenomenon with profound implications for reaction kinetics and metabolic stability.

Property	1H-Perfluorodecane	Deuterated 1H-Perfluorodecane	Rationale for Difference
Molecular Formula	C ₁₀ HF ₂₁	C ₁₀ DF ₂₁	Isotopic substitution of Hydrogen with Deuterium.
Molecular Weight	~520.08 g/mol [1]	~521.09 g/mol	Deuterium is approximately twice as heavy as protium.
Melting Point	36 °C[2]	Expected to be slightly higher	Stronger intermolecular forces due to the C-D bond.
Boiling Point	154 °C[2]	Expected to be slightly higher	Increased molecular weight and stronger van der Waals forces.
Density	1.78 g/mL @ 34 °C[2]	Expected to be slightly higher	Increased molecular mass in a similar molar volume.

The Kinetic Isotope Effect (KIE): A Deeper Dive into Reactivity

The kinetic isotope effect (KIE) is a cornerstone concept when comparing deuterated and non-deuterated compounds. It describes the change in the rate of a chemical reaction when an atom in the reactants is replaced by one of its isotopes.[3] Because the C-D bond is stronger

than the C-H bond, reactions that involve the cleavage of this bond will proceed more slowly for the deuterated compound.[4]

This principle is paramount in drug development. By selectively replacing hydrogen atoms at sites of metabolic activity with deuterium, the rate of metabolic breakdown can be significantly reduced.[4][5] This can lead to an improved pharmacokinetic profile, including a longer drug half-life, which may allow for less frequent dosing and a better safety profile by reducing the formation of toxic metabolites.[3][4][5] The first deuterated drug, deutetrabenazine, was approved by the FDA in 2017, validating this approach.[3][4][5]

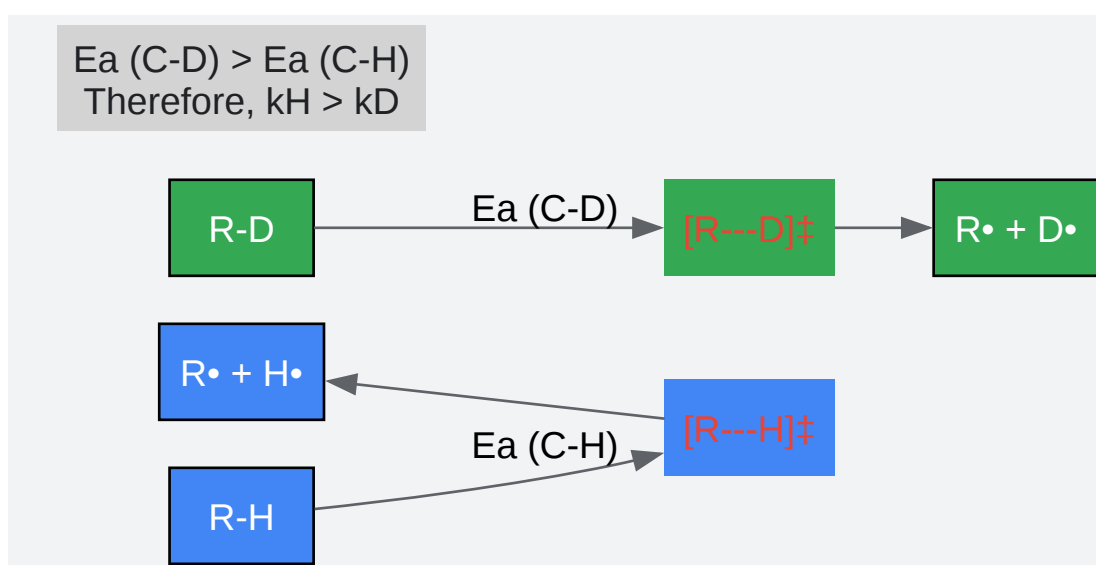

[Click to download full resolution via product page](#)

Caption: Energy profile illustrating the Kinetic Isotope Effect.

Comparative Performance in Key Scientific Applications

The distinct nuclear properties of protium and deuterium lead to significant differences in how these molecules perform in various analytical and imaging techniques.

Nuclear Magnetic Resonance (NMR) Spectroscopy

NMR spectroscopy is a powerful technique for elucidating molecular structure. In ^1H NMR, the proton in **1H-Perfluorodecane** would produce a characteristic signal. The chemical shift and

multiplicity of this signal can be influenced by the strongly electron-withdrawing perfluoroalkyl chain.[6]

Conversely, its deuterated analog would be "silent" in a standard ^1H NMR spectrum. This is because deuterium has a different nuclear spin and resonance frequency, meaning it is not detected in ^1H NMR.[7] This property is precisely why deuterated solvents are ubiquitously used in NMR; they dissolve the analyte without producing large, interfering solvent peaks.[7][8] [9] The deuterated analog of **1H-Perfluorodecane** could, therefore, serve as an excellent solvent for ^1H NMR studies of other fluorinated compounds.

^{19}F Magnetic Resonance Imaging (MRI)

Perfluorocarbons are exceptionally well-suited as contrast agents for ^{19}F MRI.[10][11] The key advantage is the near-total absence of a natural fluorine signal in biological tissues, which results in background-free imaging with a high degree of specificity.[10][12] Both **1H-Perfluorodecane** and its deuterated analog can be formulated into nanoemulsions and used for applications such as cell tracking and inflammation imaging.[13]

While the ^{19}F NMR spectrum itself would be identical for both compounds, the substitution of ^1H with ^2H could subtly influence the relaxation properties (T1 and T2) of the neighboring fluorine nuclei. This might offer a nuanced method for distinguishing between the two compounds in a mixed sample or for fine-tuning the imaging properties of the contrast agent, although this would require empirical validation.

Experimental Protocols for Comparative Analysis

To empirically validate the theoretical differences between these two compounds, a series of well-defined experiments are necessary.

Protocol: Comparative ^1H NMR Analysis

This protocol outlines the procedure to confirm the identity of **1H-Perfluorodecane** and the absence of a proton signal in its deuterated analog.

Methodology:

- Sample Preparation:

- Accurately weigh 10 mg of **1H-Perfluorodecane** and dissolve it in 0.6 mL of a deuterated solvent (e.g., CDCl₃).
- Separately, dissolve 10 mg of the deuterated **1H-Perfluorodecane** analog in 0.6 mL of the same deuterated solvent.
- Transfer each solution to a separate, clean NMR tube.
- Instrument Setup:
 - Use a standard NMR spectrometer (e.g., 400 MHz).
 - Lock the spectrometer on the deuterium signal of the solvent.
 - Shim the magnetic field to achieve optimal homogeneity.
- Data Acquisition:
 - Acquire a standard ¹H NMR spectrum for each sample.
 - Typical parameters include a 90° pulse, a spectral width of 15 ppm, and a relaxation delay of 5 seconds.
- Data Analysis:
 - Process the spectra using appropriate software (e.g., MestReNova, TopSpin).
 - For the **1H-Perfluorodecane** sample, identify the chemical shift and multiplicity of the proton signal.
 - For the deuterated sample, confirm the absence of any significant signal in the expected region, thereby verifying the success of the deuteration.

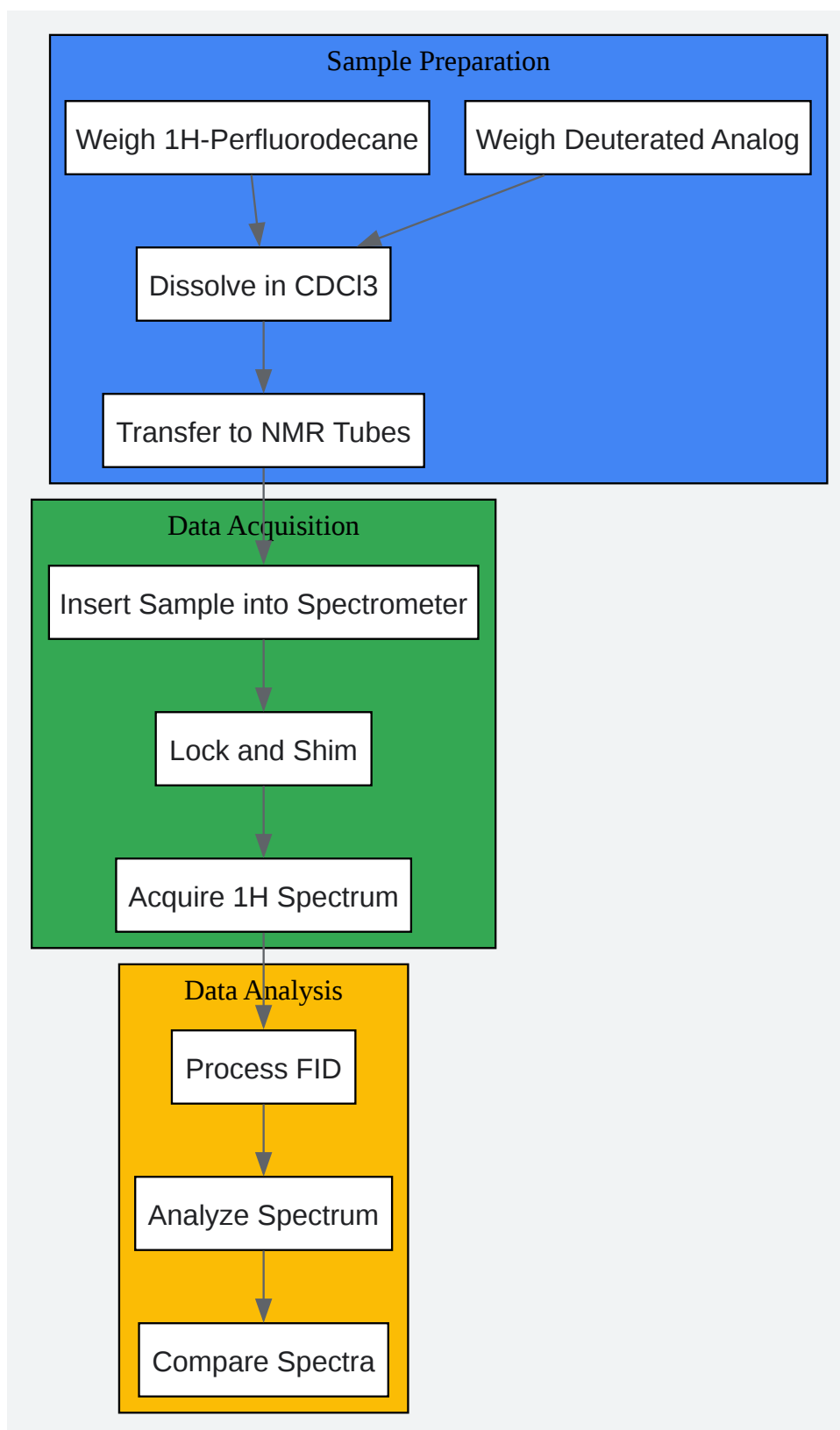

[Click to download full resolution via product page](#)

Caption: Workflow for comparative ^1H NMR analysis.

Protocol: Isotopic Purity Determination by Mass Spectrometry

This protocol is essential for quantifying the percentage of deuterium incorporation in the synthesized deuterated analog.

Methodology:

- Sample Preparation:
 - Prepare dilute solutions (e.g., 1 µg/mL) of both **1H-Perfluorodecane** and its deuterated analog in a suitable volatile solvent (e.g., methanol).
- Instrument Setup:
 - Use a high-resolution mass spectrometer (e.g., Q-TOF or Orbitrap) equipped with an appropriate ionization source (e.g., Electrospray Ionization or Chemical Ionization).
 - Calibrate the instrument to ensure high mass accuracy.
- Data Acquisition:
 - Inject the **1H-Perfluorodecane** sample to obtain a reference mass spectrum and identify the molecular ion peak ($[M-H]^-$ or $[M+H]^+$).
 - Inject the deuterated sample and acquire its mass spectrum under identical conditions.
- Data Analysis:
 - Compare the mass spectra of the two samples.
 - In the spectrum of the deuterated analog, measure the relative intensities of the peak corresponding to the fully deuterated molecule (mass M+1 compared to the protonated version) and the peak for any residual protonated molecule (mass M).
 - Calculate the isotopic purity using the formula: $\% \text{ Deuteration} = \frac{\text{Intensity(Deuterated)}}{\text{Intensity(Deuterated)} + \text{Intensity(Protonated)}} \times 100$.

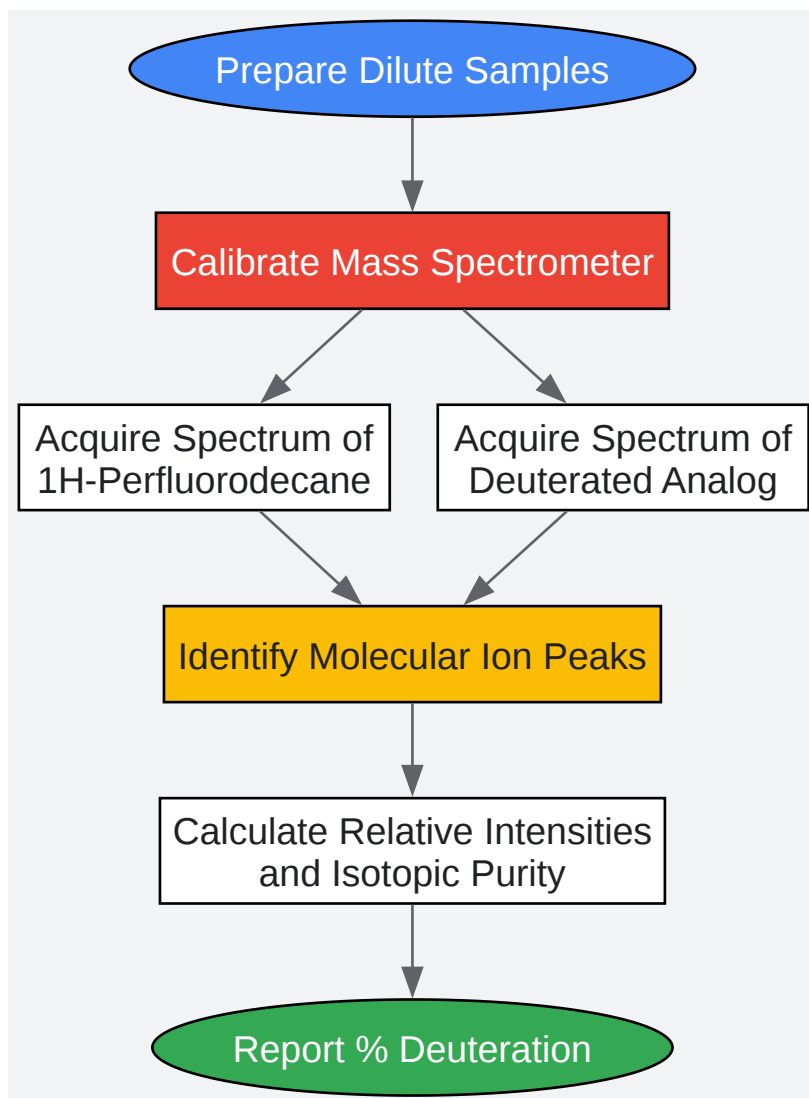

[Click to download full resolution via product page](#)

Caption: Workflow for isotopic purity determination via mass spectrometry.

Conclusion

The comparison between **1H-Perfluorodecane** and its deuterated analog highlights the profound impact of a single isotopic substitution. While the protonated version serves as a valuable fluorinated building block and imaging agent, its deuterated counterpart offers enhanced utility as a non-interfering solvent for NMR spectroscopy and presents intriguing possibilities for modulating metabolic stability in drug discovery. The choice between these two molecules is therefore dictated by the specific experimental context. Understanding their distinct properties and the methodologies to verify them is crucial for researchers and drug

development professionals seeking to leverage the unique characteristics of fluorinated and deuterated compounds in their work.

References

- ResearchGate. (2025, August 5). Kinetic Isotope Effects and Synthetic Strategies for Deuterated Carbon-11 and Fluorine-18 Labelled PET Radiopharmaceuticals | Request PDF. Retrieved from [[Link](#)]
- Study Mind. (n.d.). Analytical Techniques - Deuterium use in ^1H NMR (A-Level Chemistry). Retrieved from [[Link](#)]
- PubChem. (n.d.). 1H -Perfluorohexane. Retrieved from [[Link](#)]
- Unibest Industrial Co., Ltd. (2024, July 31). 5 Benefits of Deuteration in Drug Discovery. Retrieved from [[Link](#)]
- PubChem. (n.d.). 1,1,1,2,2,3,3,4,4,5,5,6,6,7,7,8,8,9,9,10,10-Heneicosafluorodecane. Retrieved from [[Link](#)]
- Di Martino, R.M.C., Maxwell, B.D. & Pirali, T. (2023). Deuterium in drug discovery: progress, opportunities and challenges. Nature Reviews Drug Discovery. Retrieved from [[Link](#)]
- Al-Hakami, H., Al-Malki, A., & Al-Shehri, S. (2023). Perfluorocarbons: A perspective of theranostic applications and challenges. Frontiers in Bioengineering and Biotechnology. Retrieved from [[Link](#)]
- Güden-Silber, T., Temme, S., Jacoby, C., & Flögel, U. (2018). Biomedical ^{19}F MRI Using Perfluorocarbons. Methods in Molecular Biology. Retrieved from [[Link](#)]
- ResearchGate. (n.d.). (a) ^1H NMR spectra of MMAO with increasing quantities of 1H -PFH in C_6D_6 . Retrieved from [[Link](#)]
- Mattrey, R. F., et al. (1993). Comparison of different perfluorocarbons as ultrasound contrast agents. Investigative Radiology. Retrieved from [[Link](#)]
- ResearchGate. (2025, November 6). Deuterium concentration depth profiling in sputter-deposited tungsten coated F82H using secondary ion mass spectrometry. Retrieved from

[\[Link\]](#)

- Wu, Y., et al. (2019). Perfluorocarbons-Based ^{19}F Magnetic Resonance Imaging in Biomedicine. Theranostics. Retrieved from [\[Link\]](#)
- Jarman, M., et al. (1979). The use of deuterated analogs in qualitative and quantitative investigations of the metabolism of cyclophosphamide. Cancer Treatment Reports. Retrieved from [\[Link\]](#)
- Chemistry LibreTexts. (2022, August 28). 4.7: NMR Spectroscopy. Retrieved from [\[Link\]](#)
- Atzrodt, J., Derdau, V., Fey, T., & Zimmermann, J. (2022). C–H deuteration of organic compounds and potential drug candidates. Chemical Society Reviews. Retrieved from [\[Link\]](#)
- Chapelin, F., et al. (2021). Click-Ready Perfluorocarbon Nanoemulsion for ^{19}F MRI and Multimodal Cellular Detection. ACS Nanoscience Au. Retrieved from [\[Link\]](#)
- ResearchGate. (n.d.). Three main advantages potentially provided by deuterated drugs. Retrieved from [\[Link\]](#)
- PubChem. (n.d.). Perfluorodecane. Retrieved from [\[Link\]](#)
- Pharmaffiliates. (2025, May 20). The Role of Deuterated Compounds in Pharmaceutical R&D and Testing. Retrieved from [\[Link\]](#)
- Wageningen University & Research. (2023, July 26). How to ^{19}F MRI: applications, technique, and getting started. Retrieved from [\[Link\]](#)
- EPJ Web of Conferences. (n.d.). Effective Synthesis of Deuterated n-Octylamine and Its Analogues. Retrieved from [\[Link\]](#)
- Chem Help ASAP. (2022, October 7). differences & similarities of ^1H & ^{13}C NMR spectroscopy. Retrieved from [\[Link\]](#)
- CortecNet. (2023, March 29). Reasons to use Deuterated Solvents in Nuclear Magnetic Resonance Spectroscopy. Retrieved from [\[Link\]](#)

- ResearchGate. (2025, August 10). Comparative studies of [C-11]clorgyline and deuterium substituted [C-11]clorgyline for measuring monoamine oxidase A (MAO A). Retrieved from [\[Link\]](#)
- Mesbah Energy. (2020, December 27). What are the solvents used in NMR? What is the Deuterated solvent?. Retrieved from [\[Link\]](#)
- Harbeson, S. L., et al. (2017). Altering Metabolic Profiles of Drugs by Precision Deuteration 2: Discovery of a Deuterated Analog of Ivacaftor with Differentiated Pharmacokinetics for Clinical Development. Journal of Pharmacology and Experimental Therapeutics. Retrieved from [\[Link\]](#)
- ResearchGate. (n.d.). Biomedical 19F MRI Using Perfluorocarbons | Request PDF. Retrieved from [\[Link\]](#)
- ResearchGate. (2025, August 9). 19F and 1H NMR spectra of halocarbons | Request PDF. Retrieved from [\[Link\]](#)
- ResearchGate. (n.d.). (PDF) Synthesis of completely deuterated hydrocarbons. Retrieved from [\[Link\]](#)

Need Custom Synthesis?

BenchChem offers custom synthesis for rare earth carbides and specific isotopic labeling.

Email: info@benchchem.com or [Request Quote Online](#).

Sources

- 1. 1,1,1,2,2,3,3,4,4,5,5,6,6,7,7,8,8,9,9,10,10-Heneicosafuorodecane | C10HF21 | CID 120226 - PubChem [pubchem.ncbi.nlm.nih.gov]
- 2. fluoryx.com [fluoryx.com]
- 3. Benefits and Mechanisms of Deuterated Drugs | Enhanced Efficacy [bocsci.com]
- 4. 5 Benefits of Deuteration in Drug Discovery - Unibest Industrial Co., Ltd. [unibestpharm.com]

- 5. Deuterium in drug discovery: progress, opportunities and challenges - PMC [[pmc.ncbi.nlm.nih.gov](https://pubmed.ncbi.nlm.nih.gov)]
- 6. pdf.benchchem.com [pdf.benchchem.com]
- 7. studymind.co.uk [studymind.co.uk]
- 8. Deuterated Solvents for NMR: Guide - Allan Chemical Corporation | allanchem.com [allanchem.com]
- 9. What are the solvents used in NMR? What is the Deuterated solvent? - Mesbah Energy [irisotope.com]
- 10. Biomedical ¹⁹F MRI Using Perfluorocarbons - PubMed [pubmed.ncbi.nlm.nih.gov]
- 11. Perfluorocarbons-Based ¹⁹F Magnetic Resonance Imaging in Biomedicine - PMC [[pmc.ncbi.nlm.nih.gov](https://pubmed.ncbi.nlm.nih.gov)]
- 12. researchgate.net [researchgate.net]
- 13. pubs.acs.org [pubs.acs.org]
- To cite this document: BenchChem. [A comparative study of 1H-Perfluorodecane and its deuterated analog]. BenchChem, [2026]. [Online PDF]. Available at: [<https://www.benchchem.com/product/b1663968/docs#a-comparative-study-of-1h-perfluorodecane-and-its-deuterated-analog>]

Disclaimer & Data Validity:

The information provided in this document is for Research Use Only (RUO) and is strictly not intended for diagnostic or therapeutic procedures. While BenchChem strives to provide accurate protocols, we make no warranties, express or implied, regarding the fitness of this product for every specific experimental setup.

Technical Support: The protocols provided are for reference purposes. Unsure if this reagent suits your experiment?

Need Industrial/Bulk Grade? [Request Custom Synthesis Quote](#)

BenchChem

Our mission is to be the trusted global source of essential and advanced chemicals, empowering scientists and researchers to drive progress in science and industry.

Contact

Address: 3281 E Guasti Rd

Ontario, CA 91761, United States

Phone: (601) 213-4426

Email: info@benchchem.com

[Contact our Ph.D. Support Team for a compatibility check](#)