

# The Structural & Functional Architecture of meta-Hoechst

**Author:** BenchChem Technical Support Team. **Date:** April 2026

## Compound of Interest

Compound Name: meta-Hoechst

CAS No.: 132869-83-1

Cat. No.: B1662179

[Get Quote](#)

## An In-Depth Technical Guide for Drug Development & Chemical Biology

### Part 1: Executive Technical Summary

**meta-Hoechst** (also known as HOE-S 785026 or m-Hoechst) is a structural isomer of the classical minor groove binder Hoechst 33258. While the parent compound (Hoechst 33258) features a phenolic hydroxyl group in the para position, **meta-Hoechst** positions this functional group in the meta position relative to the benzimidazole core.<sup>[1]</sup>

This subtle structural modification is not merely cosmetic; it fundamentally alters the molecule's "reading" of the DNA minor groove. By changing the vector of the hydrogen bond donor (-OH), **meta-Hoechst** acts as a molecular probe for minor groove width and hydration spine dynamics, often used to test hypotheses regarding A-T vs. G-C recognition rules. Unlike standard nuclear stains used purely for localization, **meta-Hoechst** is a tool for structural biology and rational drug design, offering insights into how small molecules can be tuned to recognize specific DNA micro-architectures.

## Part 2: Chemical Architecture & Isomerism

The defining feature of **meta-Hoechst** is the regiochemistry of the phenol ring. This shift preserves the overall crescent shape required for isohelical fit within the minor groove but alters the H-bonding network.

### Structural Comparison (DOT Visualization)

The following diagram contrasts the connectivity of the classic para-isomer (Hoechst 33258) with the meta-isomer to highlight the shift in the hydrogen bond donor vector.

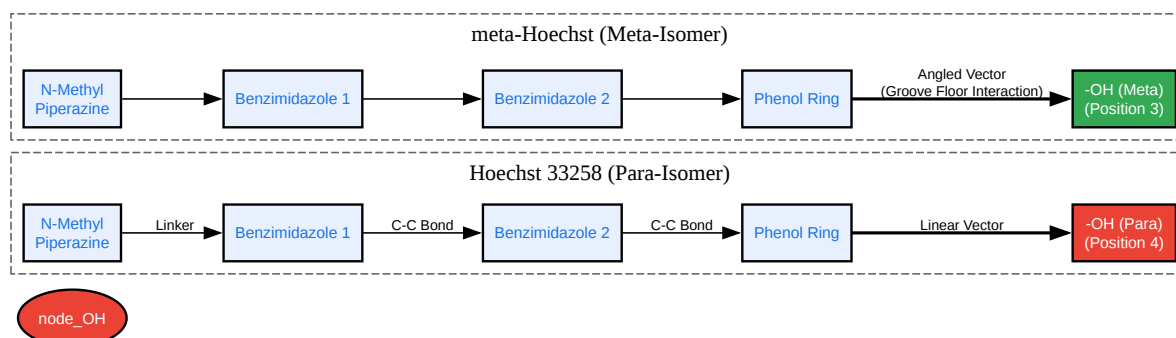

[Click to download full resolution via product page](#)

Caption: Structural logic comparison. The para-OH projects out of the groove or along the axis, while the meta-OH is positioned to interact more intimately with the groove floor or walls.

## Part 3: Synthesis & Production Logic

The synthesis of **meta-Hoechst** typically follows a convergent pathway similar to Pinner synthesis or oxidative cyclization of aldehydes with diamines. The critical divergence from Hoechst 33258 occurs in the selection of the starting aldehyde.

### Retrosynthetic Pathway

- Fragment A (Piperazine-Benzimidazole): Synthesized from 4-methylpiperazine and a nitro-chloro-benzene derivative.
- Fragment B (Meta-Phenol): Derived from 3-hydroxybenzaldehyde (instead of 4-hydroxybenzaldehyde).
- Coupling: The fragments are linked via oxidative condensation (often using sodium bisulfite or nitrobenzene as oxidant) to form the bis-benzimidazole skeleton.

#### Step-by-Step Protocol (Adapted for Research Scale):

- Precursor Preparation:
  - React 3,4-diaminobenzoic acid with N-methylpiperazine to form the first benzimidazole moiety (Fragment A).
  - Isolate as a hydrochloride salt.
- Condensation:
  - Dissolve Fragment A (diamine form) and 3-hydroxybenzaldehyde (Fragment B) in nitrobenzene.
  - Heat to 140°C for 4-6 hours. The nitrobenzene acts as both solvent and oxidizing agent to drive the formation of the imidazole ring.
- Purification:
  - Precipitate the crude product by adding excess diethyl ether.
  - Filter and wash with ether to remove nitrobenzene.
  - Crucial Step: Dissolve in hot ethanol and add concentrated HCl to precipitate the trihydrochloride salt.
  - Recrystallize from water/ethanol to achieve >98% purity (required for binding constant determination).

## Part 4: Mechanism of Action & DNA Binding Dynamics

The scientific value of **meta-Hoechst** lies in its differential binding thermodynamics.

### 1. The "Groove Width" Sensor

- Hoechst 33258 (Para): The para-hydroxyl group is relatively free to rotate or project away from the DNA floor. It binds strongly to AATT sites but tolerates some "breathing" of the helix.
- **meta-Hoechst** (Meta): The meta-hydroxyl group is sterically forced to point into the groove or towards the groove walls.
  - Geometric Lock: This creates a "geometric lock." If the minor groove is too narrow (as in pure A-tracts), the meta-OH may clash or force a specific conformation.
  - H-Bonding Potential: The meta-OH is positioned to potentially donate a hydrogen bond to the exocyclic 2-amino group of Guanine (in G-C base pairs) or the O2 of Cytosine.[1] This makes **meta-Hoechst** a key model compound for designing "GC-reading" minor groove binders.

### 2. Fluorescence Mechanism

Like its parent, **meta-Hoechst** exhibits fluorescence enhancement upon binding to dsDNA.[2] The hydrophobic environment of the minor groove suppresses non-radiative decay pathways (like solvent relaxation), resulting in a bright blue emission.

Signaling Pathway Visualization:

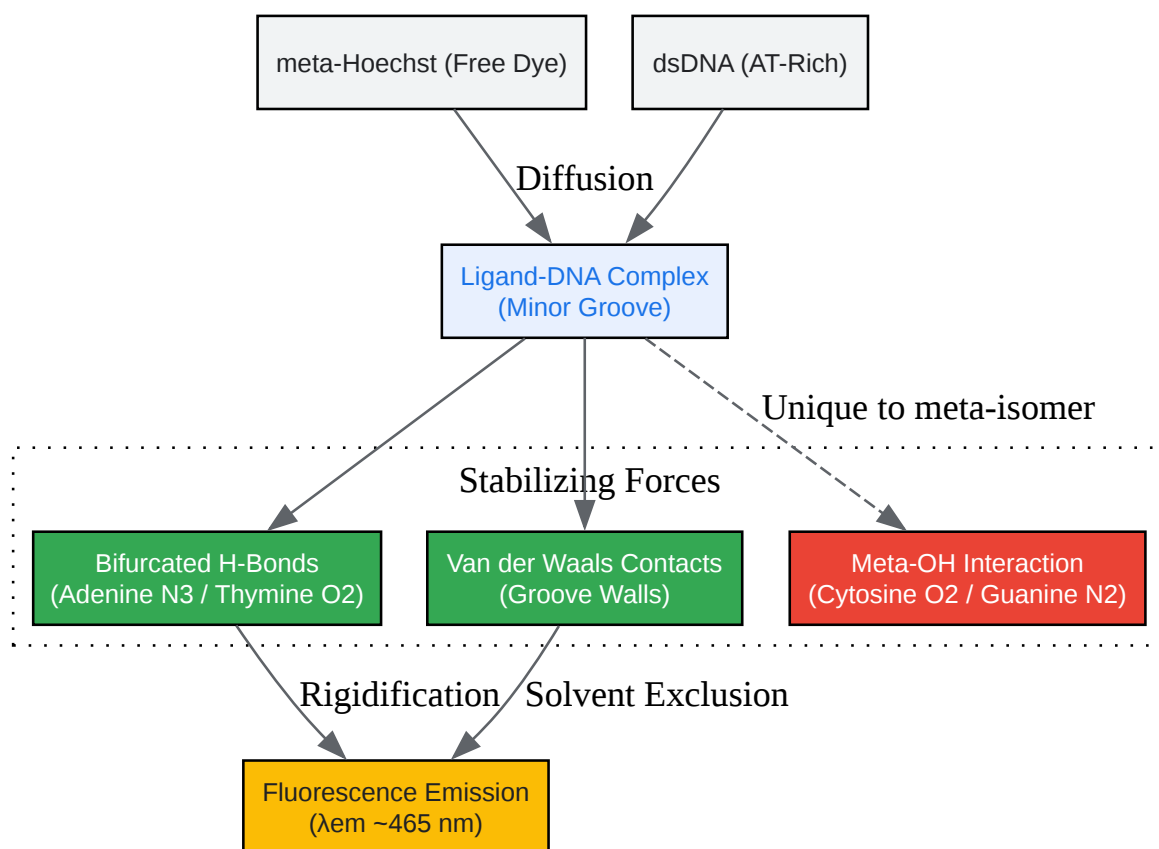

[Click to download full resolution via product page](#)

Caption: Mechanistic pathway. The meta-OH group introduces a unique interaction node (red) that probes specific H-bond acceptors on the groove floor, distinct from the para-isomer.

## Part 5: Experimental Characterization

When validating **meta-Hoechst** in the lab, use the following benchmarks.

### Table 1: Physicochemical & Spectral Properties

Property	Value / Characteristic	Notes
CAS Number	132869-83-1	Often cited as HOE-S 785026
Molecular Formula		Usually supplied as trihydrochloride
Excitation Max	350 nm	UV excitation (similar to DAPI/Hoechst 33258)
Emission Max	461 nm	Cyan-blue emission
Solubility	Water, DMSO (up to 10 mg/mL)	Stable at 4°C protected from light
Binding Constant ( )		For poly[d(A-T)]; slightly lower than p-Hoechst in some contexts
Binding Site Size	4-5 Base Pairs	Covers AATT or AAAT sites

## Protocol: Live Cell Nuclear Staining

Self-Validating Step: The appearance of distinct nuclear morphology without cytoplasmic haze confirms successful minor groove intercalation and membrane permeability.

- Preparation: Dilute stock (10 mg/mL in DMSO) to a working concentration of 0.5 - 5 µg/mL in PBS or cell culture media.
- Incubation: Add to live cells (adherent or suspension). Incubate for 20–30 minutes at 37°C.
  - Note: **meta-Hoechst** is cell-permeable.[\[3\]](#) No fixation is required, though it is compatible with fixed cells.
- Wash: Remove media and wash 3x with PBS to reduce background.
- Imaging: Use a standard DAPI/Hoechst filter set (Ex 350nm / Em 460nm).
  - QC Check: Nuclei should appear bright blue. If nucleoli are dark (unstained), this confirms specific DNA binding (as Hoechst dyes exclude RNA).

## Part 6: References

- Designer DNA-Binding Drugs: The Crystal Structure of a Meta-Hydroxy Analogue of Hoechst 33258. Source: Nucleic Acids Research (Oxford Academic). URL:[[Link](#)]
- Synthesis, DNA binding, and footprinting studies of a meta-hydroxy analogue of Hoechst 33258. Source: PubMed / Anti-Cancer Drug Design. URL:[[Link](#)]

### Need Custom Synthesis?

BenchChem offers custom synthesis for rare earth carbides and specific isotopic labeling.

Email: [info@benchchem.com](mailto:info@benchchem.com) or [Request Quote Online](#).

## Sources

- [1. Synthesis, DNA binding, footprinting and in vitro antitumour studies of a meta-hydroxy analogue of Hoechst 33258 - PubMed \[pubmed.ncbi.nlm.nih.gov\]](#)
- [2. HOE-S 785026 trihydrochloride | TargetMol \[targetmol.com\]](#)
- [3. evitachem.com \[evitachem.com\]](#)
- To cite this document: BenchChem. [The Structural & Functional Architecture of meta-Hoechst]. BenchChem, [2026]. [Online PDF]. Available at: [<https://www.benchchem.com/product/b1662179/docs#the-structural-functional-architecture-of-meta-hoechst>]

---

### Disclaimer & Data Validity:

The information provided in this document is for Research Use Only (RUO) and is strictly not intended for diagnostic or therapeutic procedures. While BenchChem strives to provide accurate protocols, we make no warranties, express or implied, regarding the fitness of this product for every specific experimental setup.

**Technical Support:** The protocols provided are for reference purposes. Unsure if this reagent suits your experiment?

**Need Industrial/Bulk Grade?** [Request Custom Synthesis Quote](#)

# BenchChem

Our mission is to be the trusted global source of essential and advanced chemicals, empowering scientists and researchers to drive progress in science and industry.

## Contact

Address: 3281 E Guasti Rd

Ontario, CA 91761, United States

Phone: (601) 213-4426

Email: [info@benchchem.com](mailto:info@benchchem.com)

[Contact our Ph.D. Support Team for a compatibility check](#)