

The Role of H2L5765834 in Lysophosphatidic Acid Signaling: A Technical Guide

Author: BenchChem Technical Support Team. **Date:** December 2025

Compound of Interest

Compound Name: H2L 5765834

Cat. No.: B1662645

[Get Quote](#)

For Researchers, Scientists, and Drug Development Professionals

Abstract

Lysophosphatidic acid (LPA) is a bioactive lipid that exerts a wide range of cellular effects through its interaction with a family of G protein-coupled receptors (GPCRs), the LPA receptors (LPARs). Dysregulation of LPA signaling has been implicated in a variety of pathological conditions, including cancer and neuropathic pain. This technical guide focuses on the compound H2L5765834, an antagonist of LPAR5, and its role in modulating LPA signaling. We will delve into its mechanism of action, its effects on downstream signaling pathways, and its potential therapeutic applications, particularly in the context of cancer-associated neuropathic pain. This document will provide a comprehensive overview of the available quantitative data, detailed experimental protocols, and visual representations of the signaling pathways involved.

Introduction to Lysophosphatidic Acid (LPA) Signaling

Lysophosphatidic acid is a simple phospholipid that acts as an extracellular signaling molecule. [1] It is produced by various cell types and is found in numerous biological fluids. LPA's diverse physiological and pathological effects are mediated by at least six specific G protein-coupled receptors: LPAR1 through LPAR6. [2] These receptors couple to various G proteins, including Gai/o, Gαq/11, Gα12/13, and Gas, to initiate a cascade of intracellular signaling events. [3] These pathways regulate fundamental cellular processes such as proliferation, migration,

survival, and cytoskeletal rearrangement.[1] The multifaceted nature of LPA signaling makes it a critical player in both normal physiological processes and in the progression of diseases like cancer.[2]

H2L5765834: An LPAR5 Antagonist

H2L5765834 is a small molecule identified as an antagonist of the lysophosphatidic acid receptor 5 (LPAR5).[4] It also exhibits antagonistic activity at LPAR1 and LPAR3, albeit with different potencies.[4] The primary therapeutic potential of H2L5765834 that has been highlighted is in the alleviation of cancer-associated neuropathic pain.[5]

Quantitative Data: Receptor Binding Affinity

The inhibitory activity of H2L5765834 has been quantified by determining its half-maximal inhibitory concentration (IC50) against various LPA receptors. The IC50 value represents the concentration of an inhibitor required to reduce the response of an agonist by 50%. A lower IC50 value indicates a higher potency of the inhibitor.

Receptor	IC50 (nM)
LPAR1	94
LPAR3	752
LPAR5	463

Table 1: IC50 values of H2L5765834 for LPAR1, LPAR3, and LPAR5.[4]

LPAR5 Signaling Pathways

LPAR5, also known as GPR92, is a G protein-coupled receptor that is activated by LPA.[6] Upon activation, LPAR5 can couple to several G proteins, leading to the activation of distinct downstream signaling pathways.

- **Gα12/13 Pathway:** Coupling to Gα12/13 activates the small GTPase Rho, which in turn activates Rho-associated kinase (ROCK). This pathway is primarily involved in regulating cell shape, motility, and cytoskeletal dynamics.[3]

- Gαq/11 Pathway:** Activation of the Gαq/11 pathway leads to the stimulation of phospholipase C (PLC). PLC hydrolyzes phosphatidylinositol 4,5-bisphosphate (PIP₂) into inositol trisphosphate (IP₃) and diacylglycerol (DAG). IP₃ triggers the release of intracellular calcium (Ca²⁺), while DAG activates protein kinase C (PKC). This pathway plays a crucial role in cell proliferation and inflammation.[3]
- Gαs Pathway:** LPAR5 can also couple to Gαs, leading to the activation of adenylyl cyclase and a subsequent increase in intracellular cyclic AMP (cAMP) levels. This pathway is often associated with the modulation of cell survival and inflammation.[3]

By blocking the activation of LPAR5, H2L5765834 can inhibit these downstream signaling cascades, thereby mitigating the pathological effects of LPA.

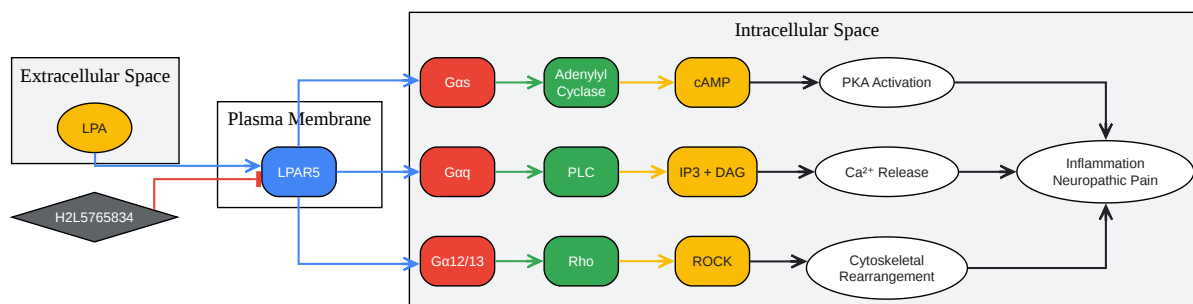

[Click to download full resolution via product page](#)

Figure 1: LPAR5 Signaling Pathway and Inhibition by H2L5765834.

Experimental Protocols

In Vitro Assay: LPA-Induced Platelet Aggregation

This protocol is based on the methods described in the study that first identified H2L5765834 as an LPAR5 antagonist.[4]

Objective: To determine the inhibitory effect of H2L5765834 on LPA-induced human platelet aggregation.

Materials:

- Freshly drawn human venous blood
- Acid-citrate-dextrose (ACD) anticoagulant
- Platelet-rich plasma (PRP)
- Platelet-poor plasma (PPP)
- Lysophosphatidic acid (LPA)
- H2L5765834
- Aggregometer

Procedure:

- Blood Collection and PRP Preparation:
 - Draw venous blood from healthy, drug-free volunteers into tubes containing ACD as an anticoagulant.
 - Centrifuge the blood at a low speed (e.g., 200 x g) for 15 minutes at room temperature to obtain platelet-rich plasma (PRP).
 - Collect the upper PRP layer.
 - Centrifuge the remaining blood at a higher speed (e.g., 1500 x g) for 10 minutes to obtain platelet-poor plasma (PPP), which will be used as a reference.
- Platelet Aggregation Assay:
 - Adjust the platelet count in the PRP to a standardized concentration (e.g., 2.5×10^8 platelets/mL) using PPP.

- Pre-warm the PRP samples to 37°C in the aggregometer cuvettes with constant stirring.
- Add H2L5765834 at various concentrations to the PRP and incubate for a specified period (e.g., 5 minutes) to allow for receptor binding.
- Initiate platelet aggregation by adding a sub-maximal concentration of LPA.
- Monitor the change in light transmission through the sample over time using the aggregometer. An increase in light transmission corresponds to platelet aggregation.
- Calculate the percentage of aggregation inhibition for each concentration of H2L5765834 compared to a vehicle control.
- Data Analysis:
 - Plot the percentage of inhibition against the logarithm of the H2L5765834 concentration.
 - Determine the IC50 value from the resulting dose-response curve.

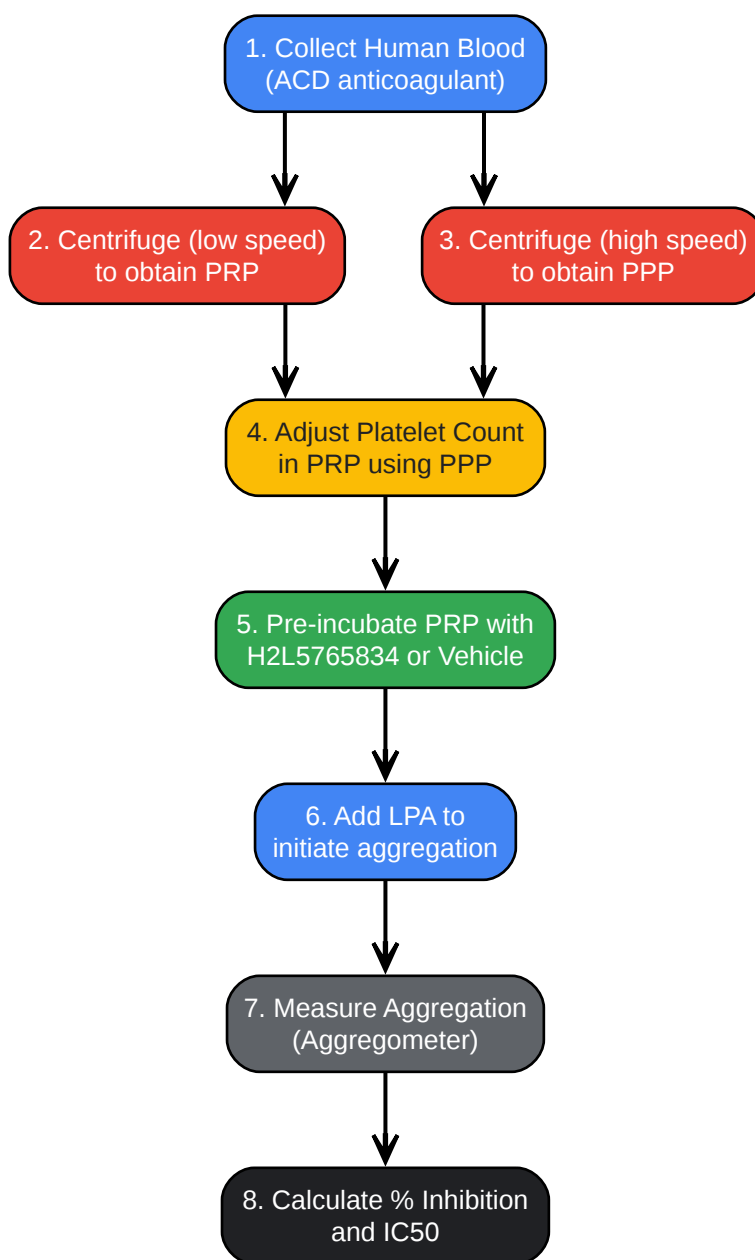

[Click to download full resolution via product page](#)

Figure 2: Experimental Workflow for Platelet Aggregation Assay.

In Vivo Model: Cancer-Associated Neuropathic Pain (Representative Protocol)

While a specific in vivo study detailing the use of H2L5765834 for cancer-associated neuropathic pain is not publicly available, the following is a representative protocol based on studies using other LPAR5 antagonists in similar pain models.

Objective: To evaluate the analgesic efficacy of H2L5765834 in a murine model of cancer-induced neuropathic pain.

Animal Model:

- Use an established model of cancer-induced bone pain, for example, by intramedullary injection of tumor cells (e.g., murine sarcoma cells) into the femur of immunocompetent mice.

Experimental Groups:

- Group 1: Sham-operated + Vehicle
- Group 2: Tumor-bearing + Vehicle
- Group 3: Tumor-bearing + H2L5765834 (at various doses)
- Group 4: Tumor-bearing + Positive Control (e.g., gabapentin)

Procedure:

- Tumor Cell Implantation:
 - Anesthetize the mice.
 - Surgically expose the femur and inject tumor cells directly into the bone marrow cavity.
 - Suture the incision and allow the animals to recover.
 - Monitor tumor growth through imaging techniques (e.g., X-ray) to confirm bone degradation.
- Drug Administration:
 - Once pain behaviors are established (typically 7-14 days post-implantation), begin administration of H2L5765834, vehicle, or positive control.

- The route of administration (e.g., oral gavage, intraperitoneal injection) and dosing schedule will depend on the pharmacokinetic properties of H2L5765834.
- Behavioral Testing for Neuropathic Pain:
 - Mechanical Allodynia: Measure the paw withdrawal threshold in response to stimulation with von Frey filaments of increasing stiffness. A lower threshold indicates increased sensitivity to mechanical stimuli.
 - Thermal Hyperalgesia: Assess the latency of paw withdrawal from a radiant heat source. A shorter latency suggests increased sensitivity to heat.
 - Perform baseline measurements before tumor implantation and at regular intervals after treatment begins.
- Data Analysis:
 - Compare the paw withdrawal thresholds and latencies between the different treatment groups.
 - Use appropriate statistical tests (e.g., ANOVA followed by post-hoc tests) to determine the significance of the observed effects.

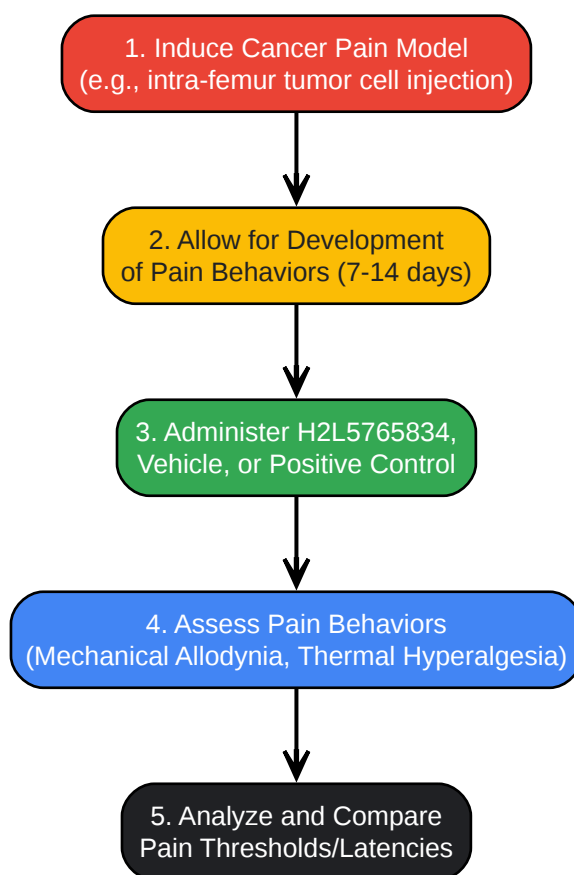

[Click to download full resolution via product page](#)

Figure 3: Workflow for In Vivo Cancer-Associated Neuropathic Pain Model.

Conclusion and Future Directions

H2L5765834 is a valuable research tool for investigating the role of LPAR5 in LPA signaling. Its antagonistic activity at LPAR5, and to a lesser extent at LPAR1 and LPAR3, makes it a compound of interest for therapeutic development, particularly for conditions where LPA signaling is dysregulated, such as in cancer-associated neuropathic pain. The provided quantitative data and experimental protocols offer a foundation for further research into the mechanism of action and therapeutic potential of H2L5765834. Future studies should aim to fully characterize its in vivo efficacy in relevant disease models, determine its pharmacokinetic and pharmacodynamic properties, and further elucidate the specific downstream signaling events it modulates. A comprehensive understanding of the role of H2L5765834 in LPA signaling will be crucial for its potential translation into a clinical setting.

Need Custom Synthesis?

BenchChem offers custom synthesis for rare earth carbides and specific isotopic labeling.

Email: info@benchchem.com or [Request Quote Online](#).

References

- 1. Unique ligand selectivity of the GPR92/LPA5 lysophosphatidate receptor indicates role in human platelet activation - PubMed [pubmed.ncbi.nlm.nih.gov]
- 2. Emerging roles of lysophosphatidic acid receptor subtype 5 (LPAR5) in inflammatory diseases and cancer - PMC [pubmed.ncbi.nlm.nih.gov]
- 3. [researchgate.net](https://www.researchgate.net) [[researchgate.net](https://www.researchgate.net)]
- 4. "Unique ligand selectivity of the GPR92/LPA5 lysophosphatidate receptor" by Jesica R. Williams, Anna L. Khandoga et al. [digitalcommons.memphis.edu]
- 5. GPR92 as a new G12/13- and Gq-coupled lysophosphatidic acid receptor that increases cAMP, LPA5 - PubMed [pubmed.ncbi.nlm.nih.gov]
- 6. An LPAR5-antagonist that reduces nociception and increases pruriception - PMC [pubmed.ncbi.nlm.nih.gov]
- To cite this document: BenchChem. [The Role of H2L5765834 in Lysophosphatidic Acid Signaling: A Technical Guide]. BenchChem, [2025]. [Online PDF]. Available at: [<https://www.benchchem.com/product/b1662645#h2l-5765834-role-in-lysophosphatidic-acid-signaling>]

Disclaimer & Data Validity:

The information provided in this document is for Research Use Only (RUO) and is strictly not intended for diagnostic or therapeutic procedures. While BenchChem strives to provide accurate protocols, we make no warranties, express or implied, regarding the fitness of this product for every specific experimental setup.

Technical Support: The protocols provided are for reference purposes. Unsure if this reagent suits your experiment? [[Contact our Ph.D. Support Team for a compatibility check](#)]

Need Industrial/Bulk Grade? [Request Custom Synthesis Quote](#)

BenchChem

Our mission is to be the trusted global source of essential and advanced chemicals, empowering scientists and researchers to drive progress in science and industry.

Contact

Address: 3281 E Guasti Rd

Ontario, CA 91761, United States

Phone: (601) 213-4426

Email: info@benchchem.com