

Technical Monograph: Rhodium(II) Octanoate Paddlewheel Complex

Author: BenchChem Technical Support Team. **Date:** May 2026

Compound of Interest

Compound Name: Octanoic acid;rhodium

CAS No.: 73482-96-9

Cat. No.: B1662050

[Get Quote](#)

Geometric Architecture, Electronic Structure, and Catalytic Protocols

Architectural Overview

The Rhodium(II) octanoate dimer,

, represents a quintessential example of the "paddlewheel" or "lantern" coordination geometry. Unlike its acetate analog, the octanoate complex incorporates long alkyl chains (

), conferring high lipophilicity. This structural modification is not merely cosmetic; it fundamentally alters the complex's solubility profile, enabling homogeneous catalysis in non-polar organic solvents (e.g., hexane, benzene) where the acetate variant is insoluble.

The complex operates under idealized

symmetry. Two rhodium atoms are bonded directly to one another, bridged by four carboxylate ligands that lock the metal core in an eclipsed conformation. The "axial" positions at the ends of the Rh-Rh bond remain open, acting as Lewis acidic sites essential for substrate activation and carbene transfer.

Geometric Analysis & Structural Parameters

The catalytic efficacy of Rh(II) octanoate is dictated by its rigid bimetallic core.

2.1 The Dirhodium Core

- **Rh-Rh Bond Length:** The single bond between the two rhodium atoms typically measures 2.38 – 2.39 Å. This distance is characteristic of tetra-bridged dirhodium(II) carboxylates.
- **Bond Order:** The molecular orbital description ($\sigma^2 \pi^4 \delta^2 \delta^2 \pi^4$) results in a formal single bond. The filling of the antibonding orbitals accounts for the relatively long metal-metal distance compared to multiple-bonded species.

2.2 Ligand Environment[1]

- **Equatorial Plane:** Four octanoate ligands bridge the metals. The oxygen atoms form a square planar geometry around each Rh atom (Rh-O distance 2.04 Å).
- **Axial Sites:** The vacant axial sites are the locus of reactivity.[2] In the absence of substrates, these may be loosely occupied by solvent molecules or remain vacant. The binding of a donor ligand (Lewis base) at the axial position significantly influences the Rh-Rh bond length and the electronic state of the distal rhodium atom (the trans effect).

Parameter	Value (Approx.)	Significance
Rh-Rh Distance	2.389 Å	Defines the bimetallic core stability.
Rh-O Distance	2.04 Å	Indicates strong carboxylate bridging.
Rh-Rh-O Angle	~88-90°	Reflects the "lantern" cage rigidity.
Symmetry		Governs orbital overlap and electronic transitions.

Electronic Structure & Reactivity

The complex is diamagnetic. Its characteristic emerald green color arises from electronic transitions within the metal-metal manifold, specifically the HOMO-LUMO gap (

).

Mechanism of Lewis Acidity: The LUMO (

) is heavily concentrated along the Rh-Rh axis, projecting outwards. This orbital availability allows the complex to accept electron density from:

- Diazo compounds: Forming metal-carbene intermediates.[3][4]
- Nucleophiles: Determining chemoselectivity in insertion reactions.

Visualization: Geometry and Electronic Pathway

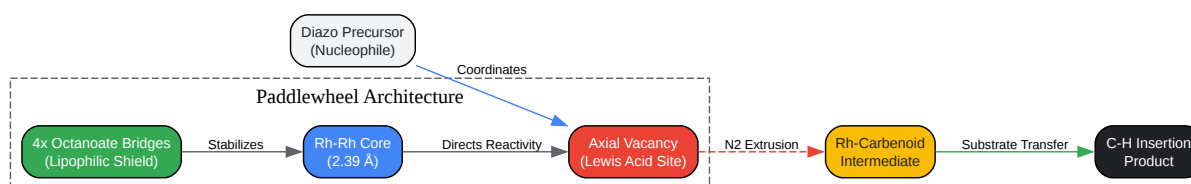

[Click to download full resolution via product page](#)

Caption: Structural logic of the Rh(II) paddlewheel, linking geometric stability to axial reactivity.

Synthesis Protocol: Ligand Exchange

Objective: Synthesize

from

via acidolysis. Precursor: Rhodium(II) Acetate (commercially available or synthesized from

).

5.1 The Protocol

- Stoichiometry: Charge a round-bottom flask with (1.0 equiv) and Octanoic acid (excess, >10 equiv). The excess acid serves as both reagent and solvent.
- Solvent System: Add chlorobenzene or toluene. While neat octanoic acid works, a co-solvent aids in azeotropic removal of acetic acid.
- Reflux & Equilibrium Drive: Attach a Dean-Stark trap or use a high-vacuum distillation setup. Heat the mixture to reflux.
 - Mechanism:[4] The reaction is an equilibrium:
.
 - Critical Step: You must remove the acetic acid (volatile) to drive the reaction to completion.
- Purification:
 - Distill off the solvent and excess octanoic acid under reduced pressure (Kugelrohr distillation is ideal).
 - The residue is a waxy green solid.
 - Recrystallize from hexane or purify via flash chromatography (if necessary) to remove trace acid.

5.2 Self-Validating Systems (QC)

- Validation 1 (Solubility): Take a small aliquot of the product and attempt to dissolve it in hexane.
 - Pass: The solid dissolves completely (Green solution).
 - Fail: Green precipitate remains (Incomplete exchange; residual acetate is insoluble in hexane).
- Validation 2 (TLC): Run TLC in 10:1 Hexane:Ethyl Acetate.

will travel (

), while

will remain at the baseline.

Applications in Drug Development

Rhodium octanoate is a premier catalyst for C-H Functionalization, a strategy that allows late-stage modification of drug scaffolds without de novo synthesis.

6.1 Intramolecular C-H Insertion

The lipophilicity of the octanoate ligands allows the catalyst to dissolve in non-polar solvents (e.g., dichloromethane, benzene) used for organic substrates.

- Reaction: Decomposition of
-diazo carbonyls.^{[2][4]}
- Outcome: Formation of
-lactams or cyclopentanones.
- Mechanism: The Rh(II) center reacts with the diazo compound to form a transient metal-carbene.^[4] This highly electrophilic species inserts into a nearby C-H bond.^[4]

6.2 Workflow Visualization

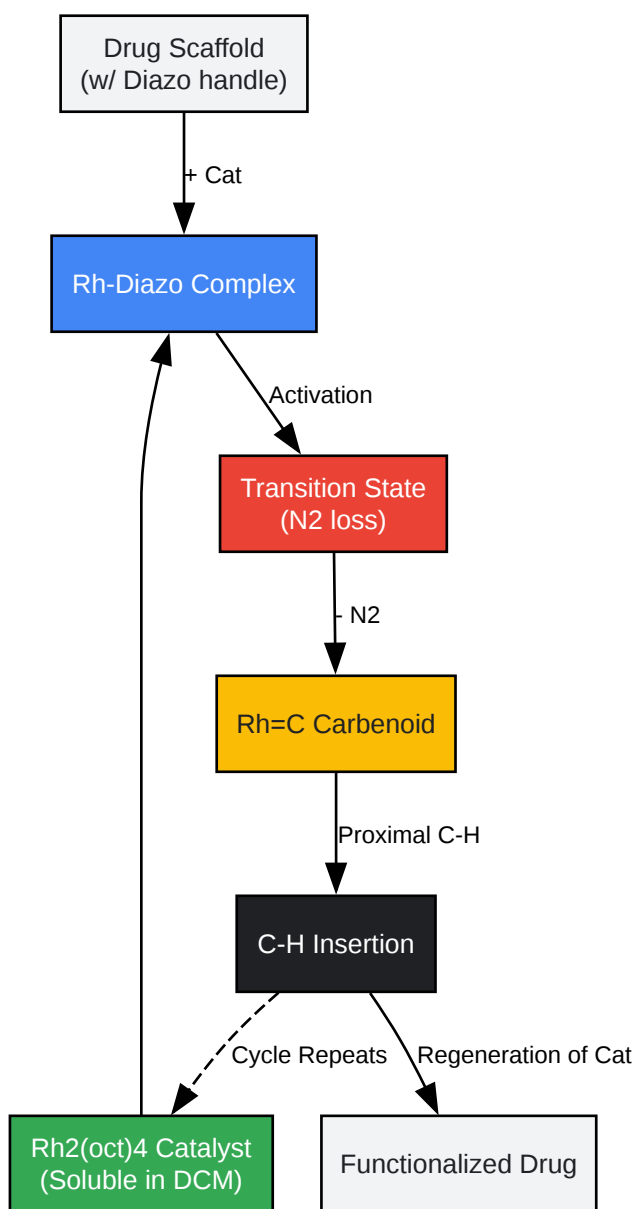

[Click to download full resolution via product page](#)

Caption: Catalytic cycle for C-H functionalization using Rh(II) octanoate.

References

- Cotton, F. A., & Walton, R. A. (1993). Multiple Bonds Between Metal Atoms. Oxford University Press. (Definitive text on the Rh-Rh bond length and paddlewheel geometry).
- Doyle, M. P., et al. (1993). "Electronic and steric control in carbon-hydrogen insertion reactions of diazoacetoacetates catalyzed by dirhodium(II) carboxylates and carboxamides." Journal of the American Chemical Society.

- Taber, D. F., & Ruckle, R. E. (1986). "Cyclopentane construction by Rh₂(OAc)₄-mediated intramolecular C-H insertion." *Journal of the American Chemical Society*.
- TCI Chemicals. (n.d.). "Rhodium(II) Octanoate Dimer Product Specifications."
- Sigma-Aldrich. (n.d.). "Rhodium(II) acetate dimer - Technical Data." (Used as core geometric reference).

Need Custom Synthesis?

BenchChem offers custom synthesis for rare earth carbides and specific isotopic labeling.

Email: info@benchchem.com or [Request Quote Online](#).

Sources

- [1. pubs.acs.org](https://pubs.acs.org) [pubs.acs.org]
- [2. par.nsf.gov](https://par.nsf.gov) [par.nsf.gov]
- [3. chemistry.illinois.edu](https://chemistry.illinois.edu) [chemistry.illinois.edu]
- [4. pubs.rsc.org](https://pubs.rsc.org) [pubs.rsc.org]
- To cite this document: BenchChem. [Technical Monograph: Rhodium(II) Octanoate Paddlewheel Complex]. BenchChem, [2026]. [Online PDF]. Available at: [<https://www.benchchem.com/product/b1662050/docs#technical-monograph-rhodium-ii-octanoate-paddlewheel-complex>]

Disclaimer & Data Validity:

The information provided in this document is for Research Use Only (RUO) and is strictly not intended for diagnostic or therapeutic procedures. While BenchChem strives to provide accurate protocols, we make no warranties, express or implied, regarding the fitness of this product for every specific experimental setup.

Technical Support: The protocols provided are for reference purposes. Unsure if this reagent suits your experiment?

Need Industrial/Bulk Grade? [Request Custom Synthesis Quote](#)

BenchChem

Our mission is to be the trusted global source of essential and advanced chemicals, empowering scientists and researchers to drive progress in science and industry.

Contact

Address: 3281 E Guasti Rd

Ontario, CA 91761, United States

Phone: (601) 213-4426

Email: info@benchchem.com

[Contact our Ph.D. Support Team for a compatibility check](#)