

Independent Validation of MLS-573151

Specificity: A Comparative Guide

Author: BenchChem Technical Support Team. **Date:** April 2026

Compound of Interest

Compound Name: *MLS-573151*

Cat. No.: *B1662975*

[Get Quote](#)

For Researchers, Scientists, and Drug Development Professionals

This guide provides an objective comparison of **MLS-573151**, a known inhibitor of the small GTPase Cdc42, with other commercially available alternatives. The following sections detail its specificity through experimental data, outline relevant experimental protocols for validation, and visualize key cellular pathways and experimental workflows.

Introduction to MLS-573151

MLS-573151 is a small molecule inhibitor that has been identified as a selective antagonist of Cell division control protein 42 homolog (Cdc42).[1] Cdc42 is a member of the Rho family of small GTPases and a key regulator of cellular processes, including cytoskeletal dynamics, cell polarity, and cell cycle progression. Dysregulation of Cdc42 activity has been implicated in various diseases, including cancer and developmental disorders. **MLS-573151** exerts its inhibitory effect by blocking the binding of guanosine triphosphate (GTP) to Cdc42, thereby preventing its activation.[1]

Comparative Analysis of Cdc42 Inhibitor Specificity

The following table summarizes the reported potency and selectivity of **MLS-573151** and other known Cdc42 inhibitors. It is important to note that these values are derived from various sources and experimental conditions, and direct, head-to-head comparisons in a single study are limited.

Compound	Target	Mechanism of Action	Potency (IC ₅₀ /EC ₅₀)	Selectivity Profile
MLS-573151	Cdc42	GTP-binding inhibitor	2 μM (EC ₅₀)[1]	Inactive against Rac1, RhoA, Rab2, Rab7, H-Ras[1]
ML141 (CID-2950007)	Cdc42	Non-competitive, allosteric inhibitor	~200 nM (IC ₅₀) [1]	Selective against Rac1, Rab2, Rab7, and Ras (up to 100 μM)[1]
ZCL367	Cdc42	Intersectin interaction inhibitor	0.098 μM (EC ₅₀)	2-fold selective over Rac1 (0.19 μM) and 303-fold over RhoA (29.7 μM)[2]
ARN22089	Cdc42	Effector interaction inhibitor	-	Blocks interaction with downstream effectors; does not block Rac1 effector interactions[3]
AZA197	Cdc42	-	-	Selective for Cdc42 without inhibition of Rac1 or RhoA in colon cancer cells[4]
NSC23766	Rac1	GEF interaction inhibitor	~50 μM (IC ₅₀)	Does not affect Cdc42 or RhoA activation

Experimental Protocols for Specificity Validation

To independently validate the specificity of **MLS-573151**, a combination of in vitro biochemical assays and cell-based assays is recommended.

GTP-Binding Assay

This biochemical assay directly measures the ability of an inhibitor to block the binding of a fluorescently labeled GTP analog to purified GTPases.

Protocol:

- **Protein Preparation:** Purify recombinant human Cdc42, Rac1, RhoA, and other GTPases of interest.
- **Assay Buffer:** Prepare an assay buffer (e.g., 20 mM Tris-HCl pH 7.5, 150 mM NaCl, 5 mM MgCl₂, 1 mM DTT).
- **Inhibitor Preparation:** Prepare a serial dilution of **MLS-573151** and control inhibitors in DMSO.
- **Reaction Setup:** In a 384-well plate, add the purified GTPase, the inhibitor at various concentrations, and a fluorescent GTP analog (e.g., BODIPY-FL-GTP).
- **Incubation:** Incubate the plate at room temperature for a defined period (e.g., 30 minutes) to allow the binding reaction to reach equilibrium.
- **Detection:** Measure the fluorescence polarization or FRET signal using a plate reader. A decrease in signal indicates inhibition of GTP binding.
- **Data Analysis:** Plot the percentage of inhibition against the inhibitor concentration and determine the IC₅₀ value for each GTPase.

G-LISA™ Cdc42 Activation Assay

This cell-based ELISA assay quantifies the level of active, GTP-bound Cdc42 in cell lysates, providing a measure of inhibitor efficacy in a cellular context.

Protocol:

- **Cell Culture and Treatment:** Culture a suitable cell line (e.g., Swiss 3T3 fibroblasts) and treat with **MLS-573151** or a vehicle control for a specified duration. Cells can be stimulated with an appropriate agonist (e.g., EGF) to activate Cdc42.
- **Cell Lysis:** Lyse the cells using the provided lysis buffer containing protease inhibitors.
- **Assay Plate:** Add the cell lysates to the wells of the G-LISA™ plate, which are coated with a Cdc42-GTP-binding protein.
- **Incubation and Washing:** Incubate the plate to allow the active Cdc42 to bind. Wash the wells to remove unbound proteins and inactive, GDP-bound Cdc42.
- **Detection:** Add a specific anti-Cdc42 antibody, followed by a secondary antibody conjugated to horseradish peroxidase (HRP).
- **Substrate Addition:** Add a colorimetric HRP substrate and measure the absorbance at 490 nm using a plate reader.
- **Data Analysis:** A decrease in absorbance in inhibitor-treated cells compared to control cells indicates a reduction in Cdc42 activation.

Cellular Thermal Shift Assay (CETSA)

CETSA is a powerful cell-based method to confirm target engagement by measuring the thermal stabilization of a protein upon ligand binding.

Protocol:

- **Cell Treatment:** Treat intact cells with **MLS-573151** or a vehicle control.
- **Heating:** Heat the cell suspensions at a range of temperatures to induce protein denaturation and aggregation.
- **Cell Lysis and Centrifugation:** Lyse the cells and separate the soluble protein fraction from the aggregated proteins by centrifugation.
- **Protein Quantification:** Quantify the amount of soluble Cdc42 in the supernatant using Western blotting or other protein detection methods.

- Data Analysis: Plot the amount of soluble Cdc42 as a function of temperature. A shift in the melting curve to a higher temperature in the presence of **MLS-573151** indicates direct binding and stabilization of Cdc42.[5]

Visualizing Cellular Pathways and Workflows

To better understand the context of **MLS-573151**'s action and the methods for its validation, the following diagrams have been generated.

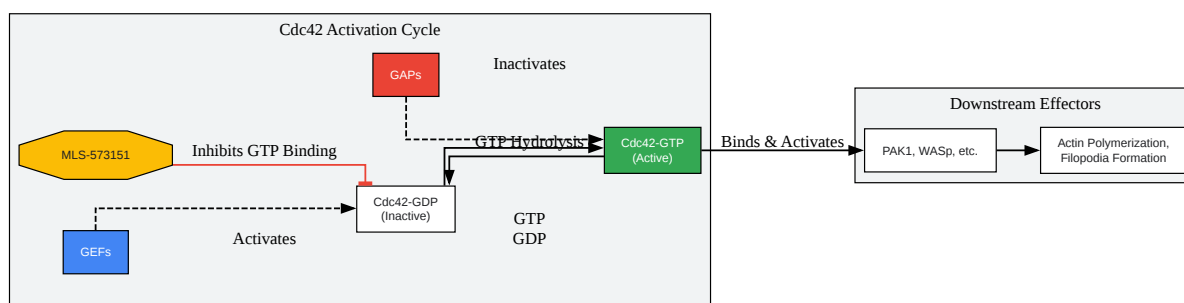

[Click to download full resolution via product page](#)

Caption: The Cdc42 activation cycle and its inhibition by **MLS-573151**.

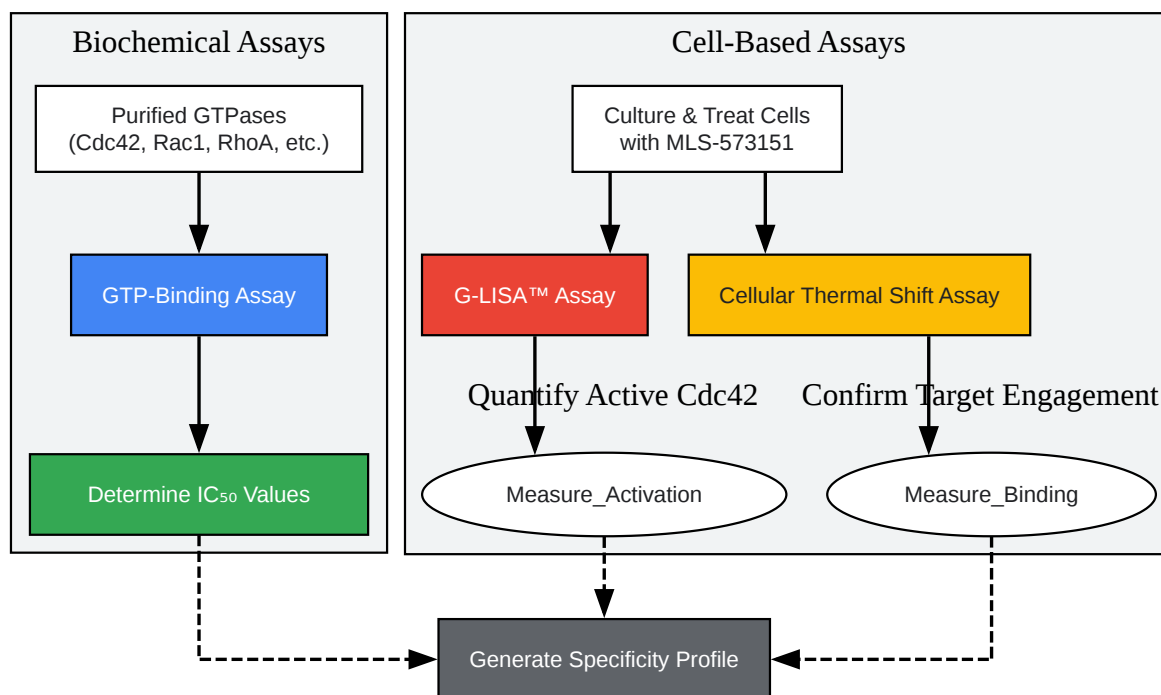

[Click to download full resolution via product page](#)

Caption: Workflow for the independent validation of **MLS-573151** specificity.

Need Custom Synthesis?

BenchChem offers custom synthesis for rare earth carbides and specific isotopic labeling.

Email: info@benchchem.com or [Request Quote Online](#).

References

- [1. A Potent and Selective Inhibitor of Cdc42 GTPase - Probe Reports from the NIH Molecular Libraries Program - NCBI Bookshelf \[ncbi.nlm.nih.gov\]](#)
- [2. Inhibition of Cdc42-intersectin interaction by small molecule ZCL367 impedes cancer cell cycle progression, proliferation, migration, and tumor growth - PubMed \[pubmed.ncbi.nlm.nih.gov\]](#)
- [3. pubs.acs.org \[pubs.acs.org\]](#)

- [4. pubs.acs.org \[pubs.acs.org\]](https://pubs.acs.org)
- [5. news-medical.net \[news-medical.net\]](https://news-medical.net)
- To cite this document: BenchChem. [Independent Validation of MLS-573151 Specificity: A Comparative Guide]. BenchChem, [2026]. [Online PDF]. Available at: [\[https://www.benchchem.com/product/b1662975/docs#independent-validation-of-mls-573151-specificity-a-comparative-guide\]](https://www.benchchem.com/product/b1662975/docs#independent-validation-of-mls-573151-specificity-a-comparative-guide)

Disclaimer & Data Validity:

The information provided in this document is for Research Use Only (RUO) and is strictly not intended for diagnostic or therapeutic procedures. While BenchChem strives to provide accurate protocols, we make no warranties, express or implied, regarding the fitness of this product for every specific experimental setup.

Technical Support: The protocols provided are for reference purposes. Unsure if this reagent suits your experiment?

Need Industrial/Bulk Grade? [Request Custom Synthesis Quote](#)

BenchChem

Our mission is to be the trusted global source of essential and advanced chemicals, empowering scientists and researchers to drive progress in science and industry.

Contact

Address: 3281 E Guasti Rd
Ontario, CA 91761, United States
Phone: (601) 213-4426
Email: info@benchchem.com

[Contact our Ph.D. Support Team for a compatibility check](#)