

# Application Notes and Protocols for the NMR Spectroscopic Analysis of Carsalam

**Author:** BenchChem Technical Support Team. **Date:** December 2025

## Compound of Interest

Compound Name: *Carsalam*

Cat. No.: *B1662507*

[Get Quote](#)

Audience: Researchers, scientists, and drug development professionals.

Abstract: This document provides a detailed guide to the nuclear magnetic resonance (NMR) spectroscopic analysis of **Carsalam** (2H-1,3-benzoxazine-2,4(3H)-dione). It includes protocols for sample preparation and data acquisition for both  $^1\text{H}$  and  $^{13}\text{C}$  NMR spectroscopy. The expected chemical shifts and coupling constants are presented in a tabular format to aid in the identification and characterization of this compound. Additionally, visualizations of the chemical structure and experimental workflow are provided to enhance understanding.

## Introduction

**Carsalam**, with the systematic name 2H-1,3-benzoxazine-2,4(3H)-dione, is a heterocyclic compound with potential applications in the pharmaceutical industry.[1][2] Accurate structural elucidation and purity assessment are critical for its development and use in research. Nuclear Magnetic Resonance (NMR) spectroscopy is a powerful analytical technique for the unambiguous determination of the chemical structure of small molecules like **Carsalam**. This application note provides the necessary protocols and expected spectral data for the characterization of **Carsalam** using  $^1\text{H}$  and  $^{13}\text{C}$  NMR.

## Chemical Structure

The chemical structure of **Carsalam** is provided below, with atoms numbered for the purpose of NMR spectral assignment.

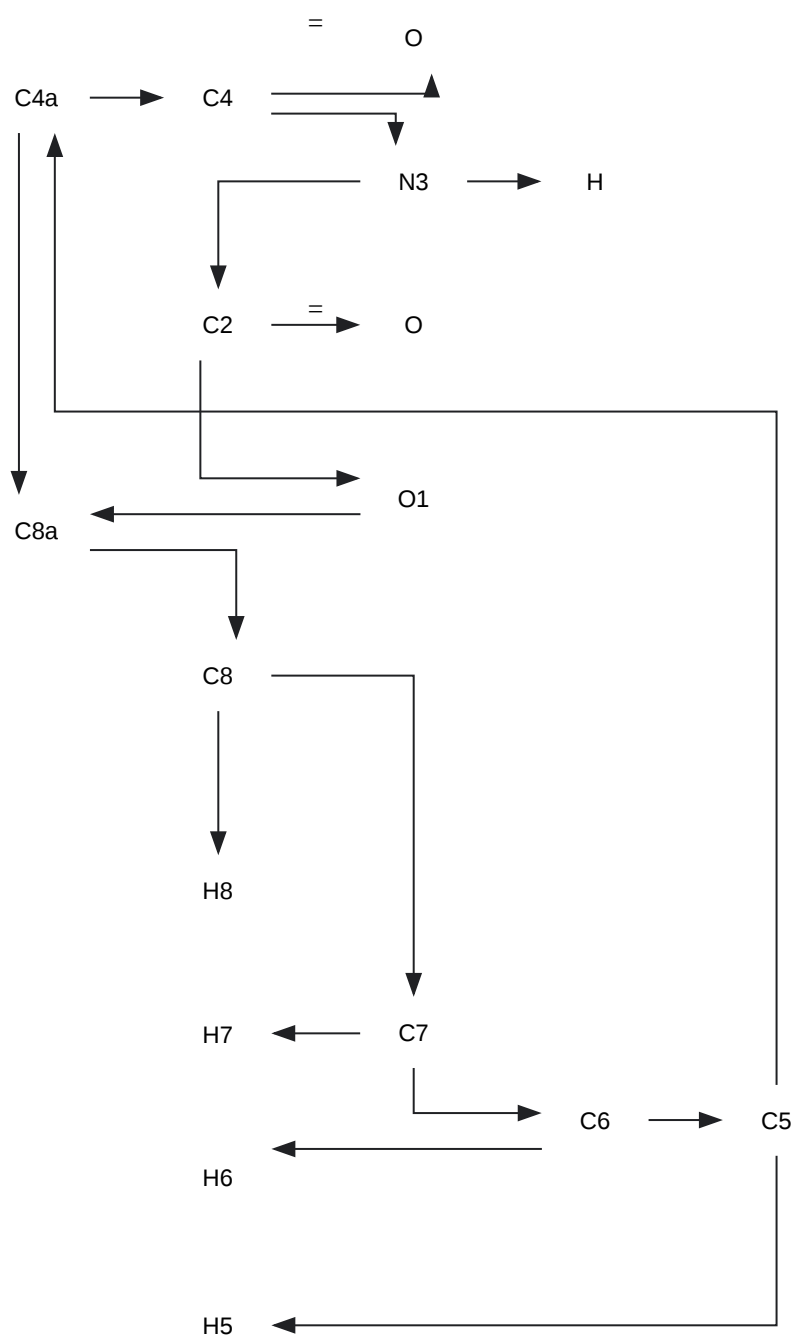

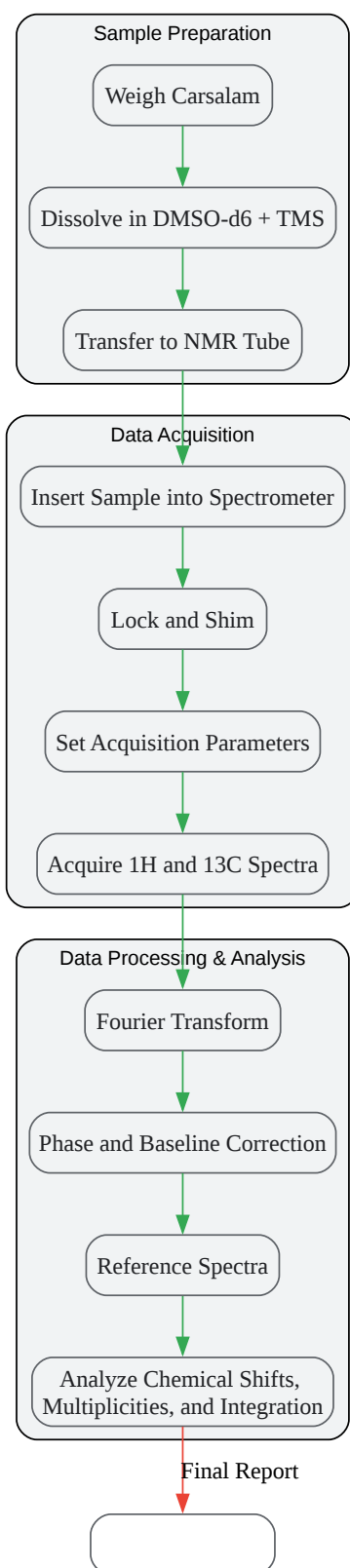

[Click to download full resolution via product page](#)

### Need Custom Synthesis?

BenchChem offers custom synthesis for rare earth carbides and specific isotopic labeling.

Email: [info@benchchem.com](mailto:info@benchchem.com) or [Request Quote Online](#).

## References

- 1. dev.spectrabase.com [dev.spectrabase.com]
- 2. 2H-1,3-Benzoxazine-2,4(3H)-dione(2037-95-8) 1H NMR [m.chemicalbook.com]
- To cite this document: BenchChem. [Application Notes and Protocols for the NMR Spectroscopic Analysis of Carsalam]. BenchChem, [2025]. [Online PDF]. Available at: [https://www.benchchem.com/product/b1662507#nuclear-magnetic-resonance-nmr-spectroscopy-of-carsalam]

### Disclaimer & Data Validity:

The information provided in this document is for Research Use Only (RUO) and is strictly not intended for diagnostic or therapeutic procedures. While BenchChem strives to provide accurate protocols, we make no warranties, express or implied, regarding the fitness of this product for every specific experimental setup.

**Technical Support:** The protocols provided are for reference purposes. Unsure if this reagent suits your experiment? [[Contact our Ph.D. Support Team for a compatibility check](#)]

**Need Industrial/Bulk Grade?** [Request Custom Synthesis Quote](#)

## BenchChem

Our mission is to be the trusted global source of essential and advanced chemicals, empowering scientists and researchers to drive progress in science and industry.

### Contact

Address: 3281 E Guasti Rd

Ontario, CA 91761, United States

Phone: (601) 213-4426

Email: [info@benchchem.com](mailto:info@benchchem.com)