

A Comparative Guide to the In Vivo Efficacy of CNQX and NBQX

Author: BenchChem Technical Support Team. **Date:** December 2025

Compound of Interest

Compound Name: CNQX disodium salt

Cat. No.: B1662576

[Get Quote](#)

For researchers and drug development professionals navigating the landscape of excitatory neurotransmission modulation, the choice between competitive AMPA/kainate receptor antagonists is critical. This guide provides a detailed comparison of two prominent quinoxalinedione derivatives, 6-cyano-7-nitroquinoxaline-2,3-dione (CNQX) and 2,3-dihydroxy-6-nitro-7-sulfamoyl-benzo[f]quinoxaline (NBQX), focusing on their in vivo efficacy, supported by experimental data.

Mechanism of Action: Targeting Excitatory Pathways

Both CNQX and NBQX act as competitive antagonists at the α -amino-3-hydroxy-5-methyl-4-isoxazolepropionic acid (AMPA) and kainate receptors, key players in mediating fast excitatory synaptic transmission in the central nervous system. By blocking these receptors, they inhibit the influx of sodium and calcium ions into postsynaptic neurons, thereby reducing neuronal excitation. This mechanism underlies their neuroprotective and anticonvulsant properties.

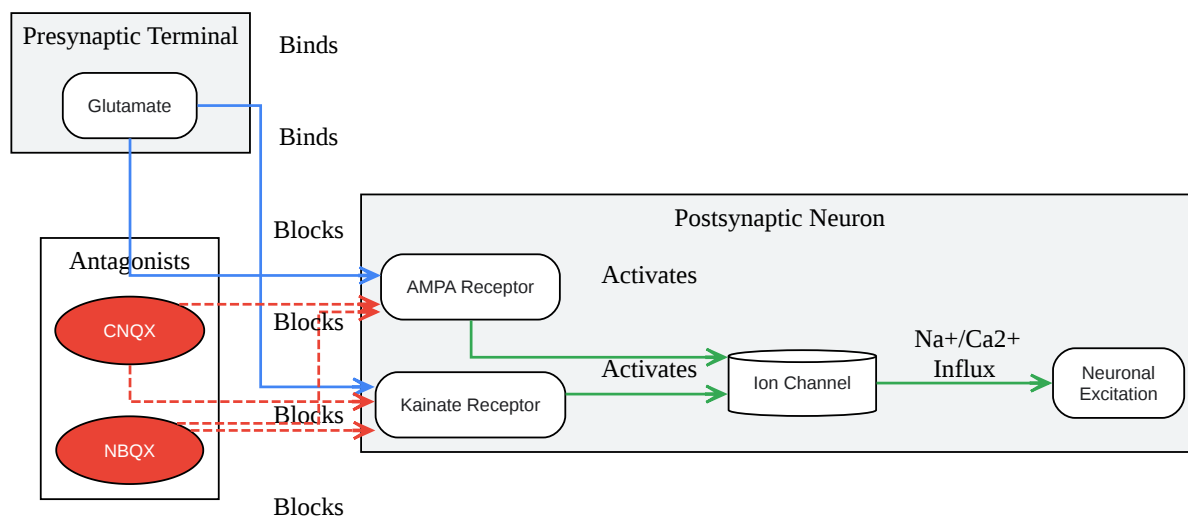

[Click to download full resolution via product page](#)

Fig. 1: Signaling pathway of AMPA/Kainate receptor antagonism by CNQX and NBQX.

In Vivo Efficacy: A Head-to-Head Comparison

The in vivo efficacy of CNQX and NBQX has been evaluated in various animal models, primarily focusing on their neuroprotective and anticonvulsant activities. The following tables summarize key quantitative data from these studies.

| Compound | Animal Model | Administration | ED50 | Efficacy (Max Inhibition) | Reference |
|----------|--------------|----------------|------------------|--|-----------|
| NBQX | Rat | i.v. | ~32 μ mol/kg | 71% - 81% (inhibition of AMPA-evoked spike activity) | [1] |
| CNQX | Rat | i.p. | 0.75 - 3 mg/kg | Blocks fear-potentiated startle | [2] |

Table 1: Comparative Anticonvulsant and Behavioral Efficacy

| Compound | Animal Model | Condition | Administration | Dosage | Outcome | Reference |
|----------|------------------------|-------------------------------|----------------|-------------------|------------------------------------|-----------|
| NBQX | Rat | Permanent Focal Ischemia | i.v. | 40, 60, 100 mg/kg | Substantially reduced infarct size | [3] |
| NBQX | Transgenic Mouse (ALS) | Amyotrophic Lateral Sclerosis | - | 8 mg/kg | Prolonged survival | [4] |
| CNQX | Rat | Ischemia Models | - | - | Shows neuroprotective effects | [2] |

Table 2: Comparative Neuroprotective Efficacy

Selectivity and Side Effect Profile

A key differentiator between CNQX and NBQX is their receptor selectivity. NBQX is considered a more selective AMPA receptor antagonist compared to CNQX, which also exhibits significant

affinity for the kainate receptor and, at higher concentrations, the glycine site of the NMDA receptor.[5][6][7] This broader activity profile of CNQX may contribute to a different side effect profile.

| Compound | Advantage | Disadvantage | Common Side Effects (in vivo) | Reference |
|----------|---|---|--|---------------|
| NBQX | More selective for AMPA receptors.[6] | May be less effective in paradigms where kainate receptors play a major role. | Ataxia at high doses (e.g., 60 mg/kg in rats).[8] In some models, can paradoxically increase seizures and mortality.[9][10] | [6][8][9][10] |
| CNQX | Broader spectrum antagonism (AMPA/kainate). | Also antagonizes the glycine site of NMDA receptors, leading to potential off-target effects.[5][7] | Can inhibit locomotor activity.[11] May impair learning at higher doses.[8] | [5][7][8][11] |

Table 3: Selectivity and Side Effect Comparison

Experimental Protocols

The following provides a generalized experimental workflow for assessing the in vivo efficacy of compounds like CNQX and NBQX in a rodent model of neuroprotection.

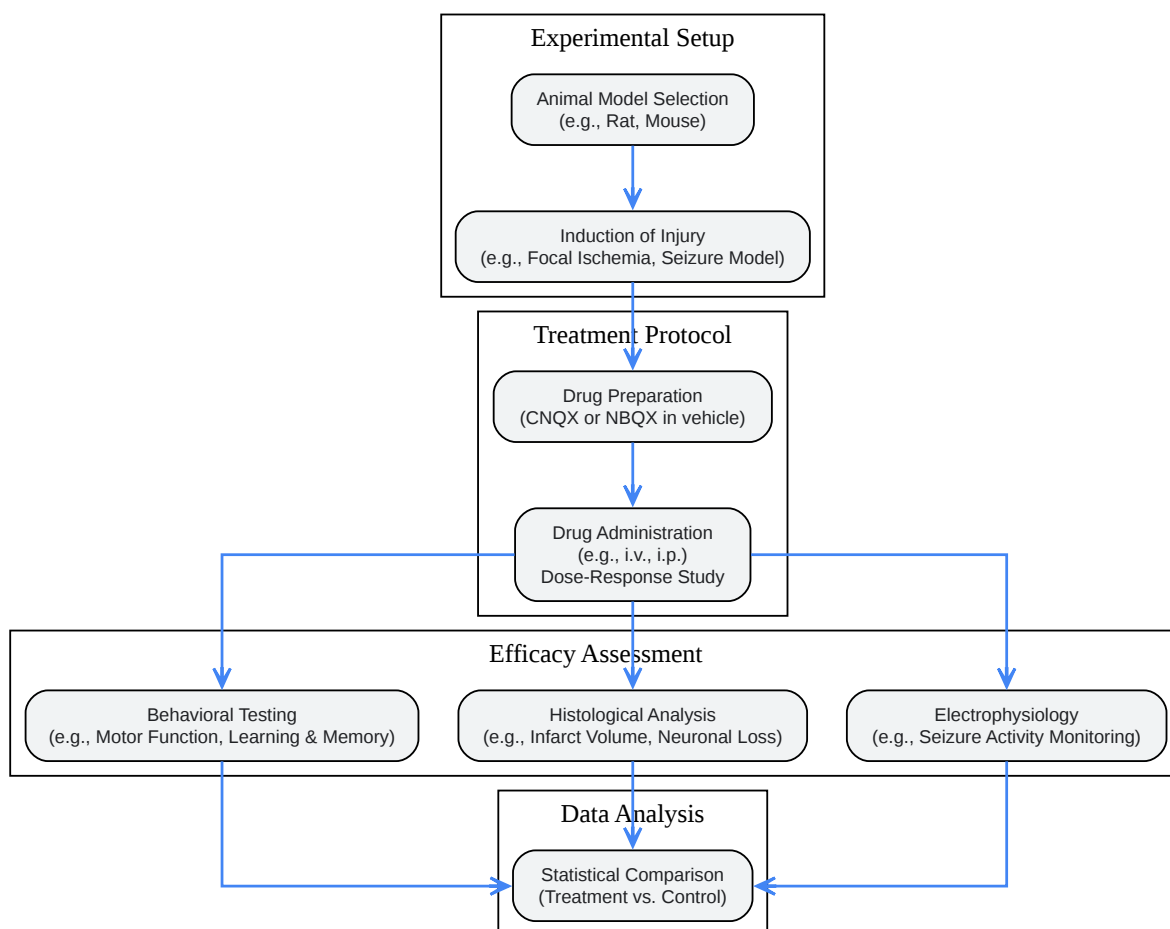

[Click to download full resolution via product page](#)

Fig. 2: General workflow for in vivo efficacy testing of neuroprotective agents.

Detailed Methodologies:

1. Animal Models:

- Focal Cerebral Ischemia: Commonly induced in rats (e.g., Sprague-Dawley) by permanent middle cerebral artery occlusion to model stroke.[3]
- Seizure Models: Can be induced chemically (e.g., with kainate) or through viral infection in mice (e.g., C57BL/6J) to study anticonvulsant effects.[9][12]
- Amyotrophic Lateral Sclerosis (ALS): Transgenic mouse models, such as those expressing a mutant human SOD1 gene (G93A), are used to investigate neuroprotective strategies in motor neuron disease.[4]

2. Drug Administration:

- Preparation: CNQX and NBQX are often dissolved in a vehicle such as saline or a solution containing DMSO, PEG300, and Tween-80 for in vivo administration.[13][14]
- Route: Intravenous (i.v.) or intraperitoneal (i.p.) injections are common routes. The choice depends on the desired pharmacokinetic profile.[2][3]

3. Efficacy Evaluation:

- Neuroprotection: Assessed by measuring infarct size in brain slices using histological staining (e.g., TTC staining) or by quantifying neuronal survival in specific brain regions.[3]
- Anticonvulsant Activity: Monitored by observing seizure frequency and severity, or through electroencephalogram (EEG) recordings.[9][12]
- Behavioral Outcomes: Evaluated using a battery of tests, including open field tests for locomotor activity, Morris water maze for learning and memory, and specific reflex tests.[8][11]

Conclusion

Both CNQX and NBQX are potent AMPA/kainate receptor antagonists with demonstrated in vivo efficacy in models of neurological disorders. The choice between them should be guided by the specific research question and the desired selectivity profile. NBQX offers higher selectivity for AMPA receptors, which may be advantageous for minimizing off-target effects.[6] Conversely, the broader spectrum of activity of CNQX might be beneficial in conditions where

both AMPA and kainate receptors play a significant pathological role. Careful consideration of the dose-response relationship and potential side effects is crucial for the successful application of these compounds in preclinical research.

Need Custom Synthesis?

BenchChem offers custom synthesis for rare earth carbides and specific isotopic labeling.

Email: info@benchchem.com or [Request Quote Online](#).

References

- 1. In vivo and in vitro evaluation of AMPA receptor antagonists in rat hippocampal neurones and cultured mouse cortical neurones - PubMed [pubmed.ncbi.nlm.nih.gov]
- 2. selleckchem.com [selleckchem.com]
- 3. A dose-response study of neuroprotection using the AMPA antagonist NBQX in rat focal cerebral ischemia - PubMed [pubmed.ncbi.nlm.nih.gov]
- 4. The AMPA receptor antagonist NBQX prolongs survival in a transgenic mouse model of amyotrophic lateral sclerosis - PubMed [pubmed.ncbi.nlm.nih.gov]
- 5. researchgate.net [researchgate.net]
- 6. NBQX, an improved non-NMDA antagonist studied in retinal ganglion cells - PubMed [pubmed.ncbi.nlm.nih.gov]
- 7. CNQX - Wikipedia [en.wikipedia.org]
- 8. Behavioral effects of NBQX, a competitive antagonist of the AMPA receptors - PubMed [pubmed.ncbi.nlm.nih.gov]
- 9. NBQX, a highly selective competitive antagonist of AMPA and KA ionotropic glutamate receptors, increases seizures and mortality following picornavirus infection - PMC [pmc.ncbi.nlm.nih.gov]
- 10. NBQX, a highly selective competitive antagonist of AMPA and KA ionotropic glutamate receptors, increases seizures and mortality following picornavirus infection - PubMed [pubmed.ncbi.nlm.nih.gov]
- 11. Some behavioral effects of CNQX AND NBQX, AMPA receptor antagonists - PubMed [pubmed.ncbi.nlm.nih.gov]
- 12. The AMPA receptor antagonist NBQX exerts anti-seizure but not antiepileptogenic effects in the intrahippocampal kainate mouse model of mesial temporal lobe epilepsy - PubMed

[pubmed.ncbi.nlm.nih.gov]

- 13. medchemexpress.com [medchemexpress.com]
- 14. The effect of CNQX on self-administration: present in nicotine, absent in methamphetamine model - PMC [pmc.ncbi.nlm.nih.gov]
- To cite this document: BenchChem. [A Comparative Guide to the In Vivo Efficacy of CNQX and NBQX]. BenchChem, [2025]. [Online PDF]. Available at: [https://www.benchchem.com/product/b1662576#comparing-the-in-vivo-efficacy-of-cnqx-and-nbqx]

Disclaimer & Data Validity:

The information provided in this document is for Research Use Only (RUO) and is strictly not intended for diagnostic or therapeutic procedures. While BenchChem strives to provide accurate protocols, we make no warranties, express or implied, regarding the fitness of this product for every specific experimental setup.

Technical Support: The protocols provided are for reference purposes. Unsure if this reagent suits your experiment? [[Contact our Ph.D. Support Team for a compatibility check](#)]

Need Industrial/Bulk Grade? [Request Custom Synthesis Quote](#)

BenchChem

Our mission is to be the trusted global source of essential and advanced chemicals, empowering scientists and researchers to drive progress in science and industry.

Contact

Address: 3281 E Guasti Rd
Ontario, CA 91761, United States
Phone: (601) 213-4426
Email: info@benchchem.com