

Technical Guide: 3-Substituted Azetidine Building Blocks for Medicinal Chemistry

Author: BenchChem Technical Support Team. **Date:** May 2026

Compound of Interest

Compound Name:	3-[(2-Methylphenyl)methyl]azetidine hydrochloride
CAS No.:	1989659-85-9
Cat. No.:	B1653839

[Get Quote](#)

Executive Summary

In the pursuit of "escaping flatland"—the transition from planar, aromatic-heavy scaffolds to sp³-rich architectures—the azetidine ring has emerged as a premier bioisostere. Unlike its carbocyclic analog (cyclobutane) or its higher homolog (pyrrolidine), the 3-substituted azetidine offers a unique combination of high polarity, lowered lipophilicity (LogP), and specific vector positioning due to ring puckering.[1][2]

This guide serves as a technical blueprint for medicinal chemists. It moves beyond basic literature reviews to provide actionable synthetic strategies, decision-making frameworks for bioisosteric replacement, and rigorous handling protocols for these strained heterocycles.[1][2]

Physicochemical Rationale: The "Why"

The azetidine ring is not merely a "smaller pyrrolidine." [2] Its incorporation drives specific physicochemical changes that are critical for optimizing ADME (Absorption, Distribution, Metabolism, Excretion) properties.[1][2]

The "Butterfly" Effect (Ring Puckering)

Unlike the planar cyclobutane, the azetidine ring exists in a puckered conformation (butterfly angle $\sim 30^\circ$).^{[1][2]} This puckering is crucial for molecular recognition.^[2]

- **Dipole Moment:** The lone pair on the nitrogen is more exposed than in pyrrolidine, but the ring strain (~ 26 kcal/mol) and puckering alter the vector of the N-substituent.
- **Basicity:** Azetidines are generally more basic than expected for their strain, often comparable to secondary amines, but functionalization at the 3-position (especially electron-withdrawing groups like fluorine) dramatically modulates this pKa.^[1]

Comparative Metrics

The following table illustrates why a chemist would shift from a pyrrolidine or piperidine to an azetidine scaffold.

Feature	Azetidine (4-membered)	Pyrrolidine (5-membered)	Cyclobutane (4-membered)	Impact on Drug Design
Ring Strain	~26 kcal/mol	~6 kcal/mol	~26 kcal/mol	High reactivity; potential metabolic hotspot if not substituted correctly.
LogP (Lipophilicity)	Low (Polar)	Medium	High (Lipophilic)	Azetidine lowers LogP, improving solubility and reducing metabolic clearance. ^{[1][2]}
pKa (Parent)	~11.3	~11.3	N/A	High basicity requires modulation (e.g., N-arylation or 3-F substitution) for bioavailability.
Bioisostere For	Gem-dimethyl; Carbonyl; Proline	Proline; Phenyl	Gem-dimethyl	Azetidine is a "polar spacer" that maintains geometry while reducing lipophilicity.

Strategic Decision Framework

Before initiating synthesis, use the following logic flow to determine if a 3-substituted azetidine is the correct tool for your SAR (Structure-Activity Relationship) campaign.

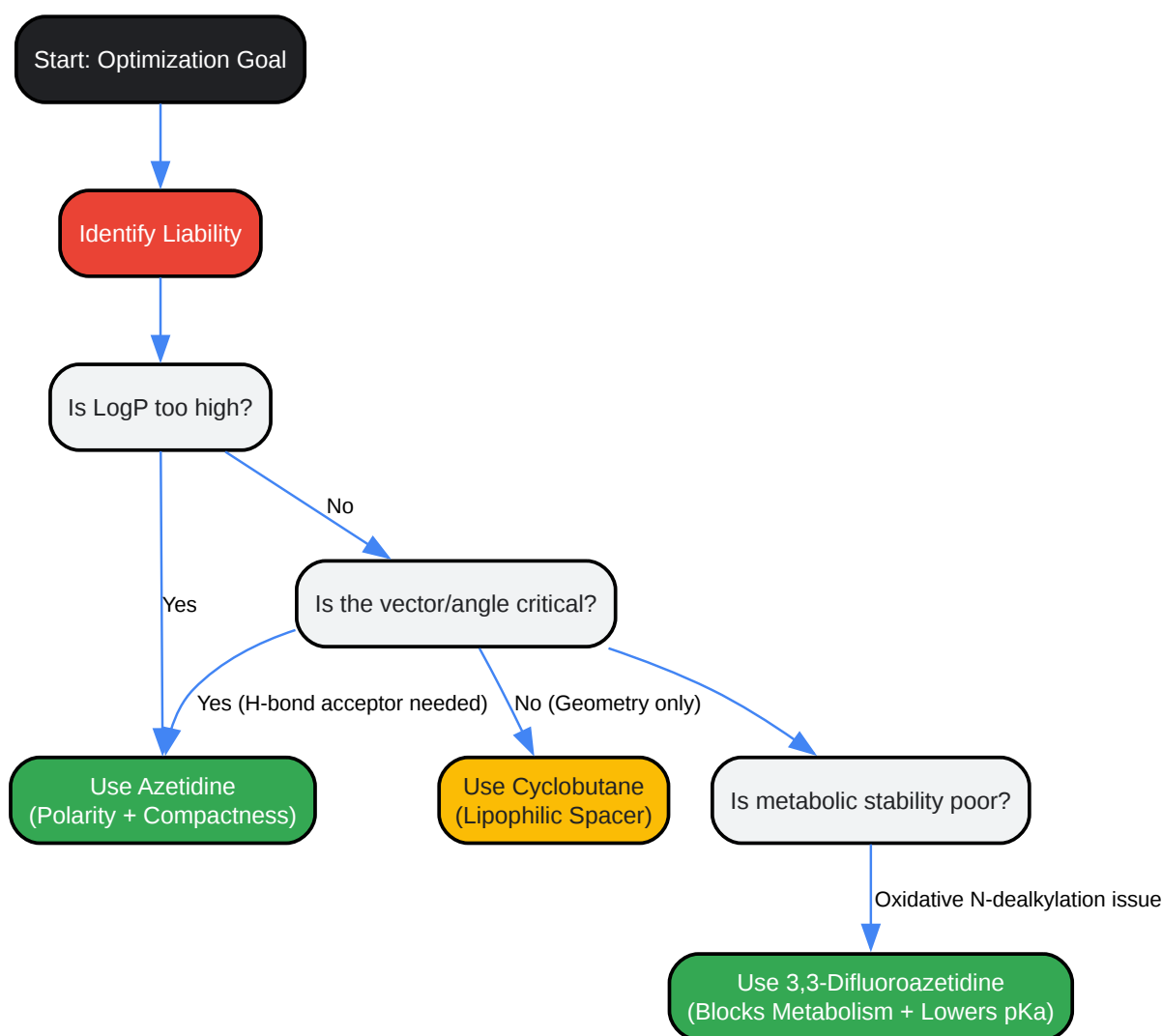

[Click to download full resolution via product page](#)

Figure 1: Decision logic for incorporating azetidine scaffolds during lead optimization.

Synthetic Access & Methodologies

Accessing 3-substituted azetidines requires overcoming the inherent ring strain. Traditional nucleophilic substitution on the ring is difficult.[2] Modern methods rely on functionalizing the 3-position via cross-coupling or reductive strategies.

Primary Route: Reductive Functionalization (from Azetidin-3-one)

The most robust entry to 3-amino or 3-aryl azetidines is via azetidin-3-one (usually N-Boc or N-Cbz protected).

- Mechanism: Formation of an imine/enamine followed by reduction.[2]
- Utility: Ideal for installing amines (reductive amination) or carbon chains (Wittig/Horner-Wadsworth-Emmons).

Advanced Route: Nickel-Catalyzed Cross-Coupling

For installing aryl groups directly at the 3-position (creating a C(sp³)-C(sp²) bond), Nickel catalysis has superseded Palladium due to better handling of alkyl halides.

- Substrate: N-Boc-3-iodoazetidine.
- Coupling Partner: Aryl zinc reagents (Negishi) or Aryl bromides (reductive cross-electrophile coupling).[1][2]

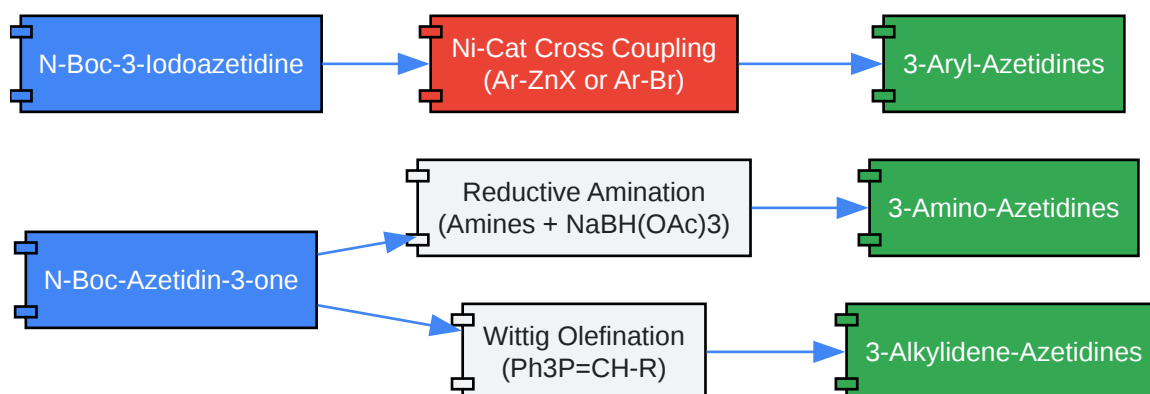

[Click to download full resolution via product page](#)

Figure 2: Primary synthetic workflows for accessing diverse 3-substituted azetidine libraries.

Strategic Applications (Case Studies) Baricitinib (JAK Inhibitor)[1][2][3]

- Role of Azetidine: The azetidine ring acts as a rigid linker connecting the pyrrolo[2,3-d]pyrimidine (hinge binder) to the ethylsulfonyl group.[1]
- Design Win: The sp³ character of the azetidine allows the sulfonyl group to orient into a specific solvent-exposed pocket, improving selectivity over other kinases.[2]
- Synthesis Insight: The core is constructed via a Horner-Wadsworth-Emmons reaction on N-Boc-azetidin-3-one to install the cyanomethylene group [1].

Cobimetinib (MEK Inhibitor)[1][2][4][5]

- Role of Azetidine: A 3-substituted azetidine is fused to a piperidine ring.
- Design Win: The azetidine amine forms a critical salt bridge with Asp190 in the MEK allosteric pocket.[2] The ring strain and puckering ensure the amine is held in a precise position that a flexible chain could not maintain [2].[2]

Experimental Protocols

Protocol A: Robust Reductive Amination (Synthesis of 3-Aminoazetidines)

Use this for rapid library generation.

Reagents:

- N-Boc-azetidin-3-one (1.0 equiv)
- Primary/Secondary Amine (1.1 equiv)[1]
- Sodium Triacetoxyborohydride (STAB) (1.5 equiv)[1]
- Acetic Acid (cat.)[1][2]
- DCM (Dichloromethane)[1]

Step-by-Step:

- Imine Formation: In a flame-dried flask under N₂, dissolve N-Boc-azetidin-3-one in anhydrous DCM (0.1 M). Add the amine and catalytic acetic acid.[2] Stir at RT for 1 hour. Note: Pre-forming the imine is crucial to avoid direct reduction of the ketone.
- Reduction: Cool to 0°C. Add STAB portion-wise. The gas evolution (H₂) indicates active hydride transfer.[2]
- Quench: After 4-16 hours (monitor by LCMS for disappearance of ketone), quench with sat. NaHCO₃.
- Workup: Extract with DCM (3x). Wash combined organics with brine.[2] Dry over Na₂SO₄. [2]
- Purification: Flash chromatography (MeOH/DCM gradient).

Protocol B: Nickel-Catalyzed Negishi Coupling (Synthesis of 3-Arylazetidines)

Use this for installing aromatic rings directly onto the sp³ core.

Reagents:

- N-Boc-3-iodoazetidine (1.0 equiv)
- Aryl Zinc Reagent (1.5 equiv, prepared in situ or commercial)[1][2]
- NiCl₂(glyme) (10 mol%)[1]
- Ligand: Pybox or di-tBu-bipy (12 mol%)
- Solvent: DMA/THF (1:1)

Step-by-Step:

- Catalyst Prep: In a glovebox or under strict Argon, mix NiCl₂(glyme) and the ligand in DMA. [1][2] Stir for 20 mins to form the active complex (often distinct color change).
- Addition: Add N-Boc-3-iodoazetidine to the catalyst mixture.

- Coupling: Add the Aryl Zinc reagent slowly via syringe.
- Reaction: Stir at RT (or mild heat, 40°C) for 12 hours.
- Safety Note: Filter through Celite to remove Nickel residues before aqueous workup to prevent emulsion formation.[2]

Troubleshooting & Handling

1. Stability of the Free Base:

- Risk: 3-substituted azetidines, especially secondary amines, can polymerize or ring-open upon prolonged storage as free bases due to ring strain.
- Solution: Always store as the HCl or TFA salt.[2] If the free base is required for a reaction, generate it in situ or use immediately after workup.[1][2]

2. N-Deprotection Challenges:

- Risk: Acidic deprotection (TFA/HCl) of N-Boc groups is standard, but if the 3-substituent is acid-sensitive, the ring can open.
- Solution: For sensitive substrates, use N-Cbz protection and deprotect via hydrogenolysis (H₂, Pd/C), which is remarkably gentle on the strained ring.[1][2]

3. The "Gem-Difluoro" Trap:

- Insight: 3,3-difluoroazetidine is a popular motif, but it significantly lowers the nucleophilicity of the ring nitrogen (inductive effect).[1]
- Adjustment: When N-alkylating 3,3-difluoroazetidine, you will require higher temperatures or stronger bases (e.g., Cs₂CO₃ in DMF at 80°C) compared to the non-fluorinated analog.[1]

References

- Duncton, M. A. (2016).[1][2] Azetidines in medicinal chemistry. *Med. Chem. Commun.*, 7, 13-14.[1][2]

- Rice, K. D., et al. (2012).[1][2] Novel Carboxamide-Based Allosteric MEK Inhibitors: Discovery and Optimization Efforts leading to Cobimetinib. ACS Med.[2] Chem. Lett., 3(5), 416–421.[1][2]
- Mykhailiuk, P. K. (2018).[1][2] Saturated Bioisosteres of Benzene: Where to Go Now?. Org. [2][3][4][5] Biomol. Chem., 16, 1423-1428.[1][2]
- Lilly, E. & Co. (2009).[1][2] Patent WO2009114512: Preparation of azetidine derivatives as JAK inhibitors.[2]

Need Custom Synthesis?

BenchChem offers custom synthesis for rare earth carbides and specific isotopic labeling.

Email: info@benchchem.com or [Request Quote Online](#).

Sources

- 1. pubs.acs.org [pubs.acs.org]
- 2. Pyrrolidine - Wikipedia [en.wikipedia.org]
- 3. Cobimetinib | C₂₁H₂₁F₃N₃O₂ | CID 16222096 - PubChem [pubchem.ncbi.nlm.nih.gov]
- 4. Azetidine synthesis [organic-chemistry.org]
- 5. pubs.rsc.org [pubs.rsc.org]
- To cite this document: BenchChem. [Technical Guide: 3-Substituted Azetidine Building Blocks for Medicinal Chemistry]. BenchChem, [2026]. [Online PDF]. Available at: [<https://www.benchchem.com/product/b1653839/docs#technical-guide-3-substituted-azetidine-building-blocks-for-medicinal-chemistry>]

Disclaimer & Data Validity:

The information provided in this document is for Research Use Only (RUO) and is strictly not intended for diagnostic or therapeutic procedures. While BenchChem strives to provide accurate protocols, we make no warranties, express or implied, regarding the fitness of this product for every specific experimental setup.

Technical Support: The protocols provided are for reference purposes. Unsure if this reagent suits your experiment?

Need Industrial/Bulk Grade? [Request Custom Synthesis Quote](#)

BenchChem

Our mission is to be the trusted global source of essential and advanced chemicals, empowering scientists and researchers to drive progress in science and industry.

Contact

Address: 3281 E Guasti Rd
Ontario, CA 91761, United States
Phone: (601) 213-4426
Email: info@benchchem.com

[Contact our Ph.D. Support Team for a compatibility check](#)