

Application Note: Functional Dye Synthesis via -Dibutyl-4-ethenylaniline

Author: BenchChem Technical Support Team. **Date:** May 2026

Compound of Interest

Compound Name: *N,N-Dibutyl-4-ethenylaniline*

CAS No.: 160469-44-3

Cat. No.: B1652741

[Get Quote](#)

Introduction & Strategic Value

-Dibutyl-4-ethenylaniline is a versatile styrene derivative characterized by a strong electron-donating amine coupled to a reactive vinyl handle. Unlike its dimethyl or diphenyl analogs, the dibutyl substitution provides superior solubility in non-polar organic solvents and enhanced permeability in lipid bilayers, making it ideal for:

- Bioimaging Probes: Lipophilic membrane trackers and voltage-sensitive dyes.
- Organic Electronics: High-solubility donors for Dye-Sensitized Solar Cells (DSSCs) and Nonlinear Optical (NLO) materials.
- Fluorescent Polymers: Monomers for chemically responsive "turn-off" sensors (e.g., for nitroaromatic explosives).

The vinyl group serves as a direct conjugation bridge, allowing for atom-economic synthesis via Palladium-catalyzed coupling (Heck reaction) or radical polymerization, avoiding the multi-step aldehyde-generation routes often required for other aniline precursors.

Chemical Properties & Handling[1][2]

- CAS: [Generic Styrene Derivative Class]
- Molecular Formula: C
H
N
- Appearance: Yellowish viscous oil or low-melting solid.
- Stability: Prone to spontaneous polymerization if stored without inhibitors (e.g., TBC). Store at -20°C under Argon.
- Solubility: Excellent in DCM, THF, Toluene, Hexane. Insoluble in water.

Safety Advisory

Warning: Styrene derivatives are potential irritants and sensitizers. Handle in a fume hood. Spontaneous polymerization can be exothermic; ensure stabilizer presence (10-50 ppm 4-tert-butylcatechol) during storage.

Synthesis Workflows (Visualized)

The following diagram outlines the two primary synthetic pathways: Heck Coupling for small molecule dyes and Radical Polymerization for functional materials.

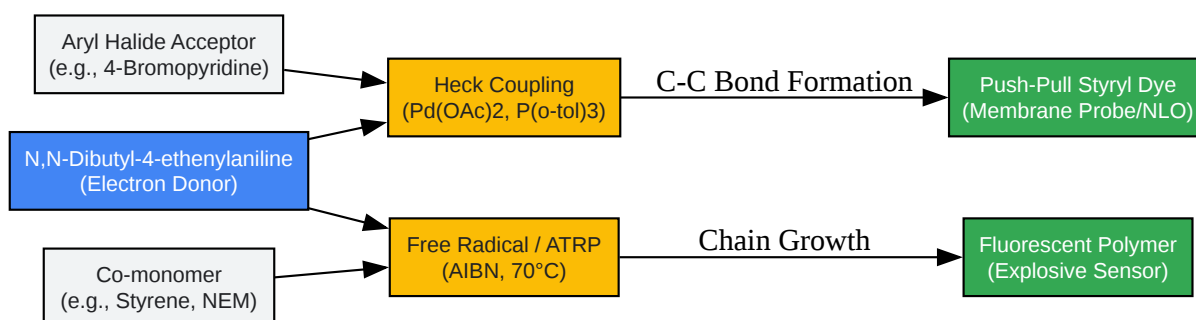

[Click to download full resolution via product page](#)

Figure 1: Divergent synthetic pathways for **N,N-Dibutyl-4-ethenylaniline** utilizing the vinyl handle.

Protocol A: Synthesis of Push-Pull Styryl Dyes (Heck Coupling)

Objective: Synthesis of a lipophilic pyridinium-styryl dye (analogous to FM dyes) for membrane imaging. Mechanism: Palladium-catalyzed cross-coupling between the vinyl group (donor) and an aryl halide (acceptor).

Materials

- Precursor:
 - Dibutyl-4-ethenylaniline (1.0 equiv)
- Acceptor: 1-Methyl-4-bromopyridinium iodide (1.2 equiv) (or similar electron-deficient halide)
- Catalyst: Palladium(II) acetate (Pd(OAc)₂, 5 mol%)
- Ligand: Tri-*o*-tolylphosphine (P(*o*-tol)₃, 10 mol%)
- Base: Triethylamine (TEA, 3.0 equiv)
- Solvent: DMF (Anhydrous)

Step-by-Step Methodology

- Preparation: In a flame-dried Schlenk tube, dissolve the Acceptor (1.2 mmol) and Base (3.0 mmol) in anhydrous DMF (5 mL). Degas with Argon for 15 minutes.
- Catalyst Addition: Add Pd(OAc)₂ and P(*o*-tol)₃ under a positive stream of Argon. The solution typically turns yellow/orange.

- Precursor Injection: Add
 - Dibutyl-4-ethenylaniline (1.0 mmol) via syringe.
- Reaction: Seal the tube and heat to 100°C for 12–24 hours. Monitor via TLC (DCM/MeOH 9:1). The fluorescent product will appear as a distinct spot (usually red/orange emission under UV).
- Work-up:
 - Cool to room temperature.^{[1][2]}
 - Pour into diethyl ether (50 mL) to precipitate the cationic dye (if using cationic acceptor).
 - Filter the precipitate and wash with excess ether to remove unreacted aniline and catalyst ligands.
- Purification: Recrystallize from Methanol/Ether or purify via column chromatography (Silica gel, DCM
DCM/MeOH gradient).

Expert Insight: The dibutyl chains significantly improve the solubility of the final cationic dye in organic solvents compared to dimethyl analogs, facilitating easier purification and handling.

Protocol B: Synthesis of Fluorescent Polymeric Sensors

Objective: Creation of a "Turn-Off" fluorescent polymer for detecting nitroaromatics (e.g., TNT, Picric Acid). Mechanism: Free radical copolymerization creates a polymer backbone with pendant fluorophores.

Materials

- Monomer A:
 - Dibutyl-4-ethenylaniline (10 wt%)

- Monomer B: Styrene (90 wt%) (Purified to remove inhibitor)
- Initiator: AIBN (Azobisisobutyronitrile) (1 wt% relative to monomers)
- Solvent: Toluene (Dry)

Step-by-Step Methodology

- Inhibitor Removal: Pass Styrene through a basic alumina column to remove TBC inhibitor immediately before use.
- Mixing: In a polymerization ampoule, combine Monomer A, Monomer B, and AIBN in Toluene (monomer concentration ~20 wt%).
- Degassing (Critical): Perform three Freeze-Pump-Thaw cycles to remove oxygen, which quenches radicals and fluorescence. Backfill with Nitrogen.[2][3]
- Polymerization: Seal the ampoule and immerse in an oil bath at 70°C for 24 hours.
- Precipitation: Drop the viscous reaction mixture slowly into cold Methanol (10x volume) under vigorous stirring. The polymer will precipitate as a fibrous white/yellow solid.
- Purification: Reprecipitate twice (THF Methanol) to remove unreacted monomers.
- Drying: Vacuum dry at 40°C overnight.

Data Interpretation:

- Fluorescence: The polymer should exhibit strong blue-green emission (nm).
- Sensing Test: Dissolve polymer in THF. Add aliquots of picric acid. Fluorescence quenching (Stern-Volmer plot) confirms sensor activity via Photoinduced Electron Transfer (PET).

Characterization & Validation Standards

Technique	Expected Result	Diagnostic Value
H NMR	Disappearance of vinyl protons (5.0–6.7 ppm)	Confirms polymerization or coupling completion.
UV-Vis	Bathochromic shift (Red shift)	Indicates extension of conjugation (Heck product).
Fluorescence	High Quantum Yield ()	Validates chromophore integrity (no oxidation).
GPC	Single peak, PDI < 2.0	Confirms uniform polymer synthesis (Protocol B).

References

- Styryl Dye Synthesis & Tuning
 - Boulayer, S., et al. (2019). "Molecular Tuning of Styryl Dyes Leads to Versatile and Efficient Plasma Membrane Probes." BioRxiv.
 - Context: Describes the Vilsmeier/Knoevenagel route for similar dyes; the Heck protocol above is the direct analog for vinyl precursors.
- Polymerization & Sensing Applications
 - Baran, D., et al. (2012). "Processable multipurpose conjugated polymer for electrochromic and photovoltaic applications.
 - Context: Demonstrates the utility of triphenylamine/dialkylaniline deriv
- General Reactivity of Vinyl Anilines
 - ChemicalBook Entry: 4-(Dimethylamino)styrene (Analogous reactivity profile).
 - Context: Provides baseline physical property data and safety handling for dialkylaminostyrenes.

Need Custom Synthesis?

BenchChem offers custom synthesis for rare earth carbides and specific isotopic labeling.

Email: info@benchchem.com or [Request Quote Online](#).

Sources

- [1. mdpi.com \[mdpi.com\]](https://www.mdpi.com)
- [2. 3-Vinylaniline synthesis - chemicalbook \[chemicalbook.com\]](#)
- [3. 4-Ethynyl-N,N-diphenylaniline - PMC \[pmc.ncbi.nlm.nih.gov\]](https://pubmed.ncbi.nlm.nih.gov/)
- To cite this document: BenchChem. [Application Note: Functional Dye Synthesis via -Dibutyl-4-ethenylaniline]. BenchChem, [2026]. [Online PDF]. Available at: [\[https://www.benchchem.com/product/b1652741/docs#application-note-functional-dye-synthesis-via-dibutyl-4-ethenylaniline\]](https://www.benchchem.com/product/b1652741/docs#application-note-functional-dye-synthesis-via-dibutyl-4-ethenylaniline)

Disclaimer & Data Validity:

The information provided in this document is for Research Use Only (RUO) and is strictly not intended for diagnostic or therapeutic procedures. While BenchChem strives to provide accurate protocols, we make no warranties, express or implied, regarding the fitness of this product for every specific experimental setup.

Technical Support: The protocols provided are for reference purposes. Unsure if this reagent suits your experiment?

Need Industrial/Bulk Grade? [Request Custom Synthesis Quote](#)

BenchChem

Our mission is to be the trusted global source of essential and advanced chemicals, empowering scientists and researchers to drive progress in science and industry.

Contact

Address: 3281 E Guasti Rd

Ontario, CA 91761, United States

Phone: (601) 213-4426

Email: info@benchchem.com

Contact our Ph.D. Support Team for a compatibility check