

Application Notes and Protocols: 2,5-Dimethylphenol as an Antioxidant in Materials Science

Author: BenchChem Technical Support Team. **Date:** December 2025

Compound of Interest

Compound Name: 2,5-Dimethylphenol

Cat. No.: B165462

[Get Quote](#)

For Researchers, Scientists, and Drug Development Professionals

These application notes provide a comprehensive overview of the utilization of **2,5-Dimethylphenol** as an antioxidant in materials science. The document details its mechanism of action, provides protocols for its incorporation and evaluation in polymeric materials, and presents illustrative performance data.

Introduction to 2,5-Dimethylphenol as an Antioxidant

2,5-Dimethylphenol, a member of the xylenol family of isomers, is a phenolic compound with significant industrial applications, including its use as a precursor in the manufacturing of antioxidants.[1] Phenolic antioxidants are primary antioxidants that act as free-radical scavengers, crucial for protecting polymeric materials from degradation caused by oxidative processes.[2][3] The presence of a hydroxyl group on the aromatic ring allows **2,5-Dimethylphenol** to donate a hydrogen atom to reactive radical species, thus neutralizing them and preventing the propagation of degradative chain reactions that can lead to material failure. [3] This makes it a valuable additive for enhancing the lifespan and performance of various polymers, including polyolefins and elastomers.[4][5]

Mechanism of Action: Free Radical Scavenging

The primary antioxidant function of **2,5-Dimethylphenol** in materials is to interrupt the auto-oxidation cycle of polymers. This cycle is a free-radical chain reaction initiated by heat, UV light, or mechanical stress. The process can be broadly categorized into initiation, propagation, and termination steps. **2,5-Dimethylphenol** intervenes in the propagation step.

The free-radical scavenging mechanism of **2,5-Dimethylphenol** is illustrated in the signaling pathway diagram below.

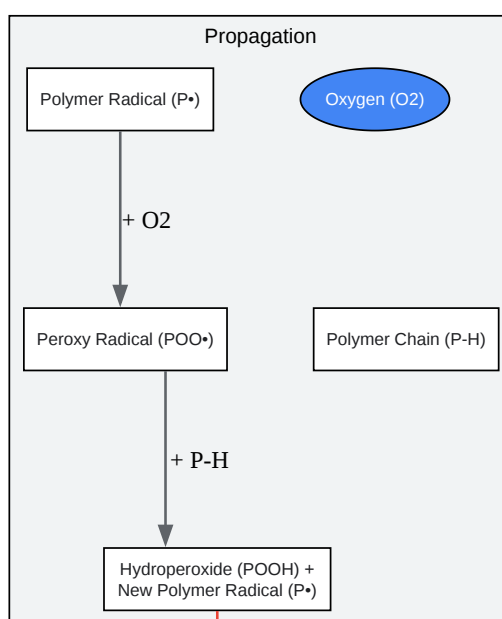
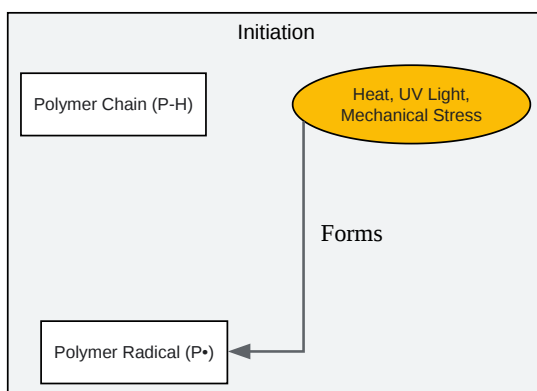

Leads to more radicals,
but is intercepted

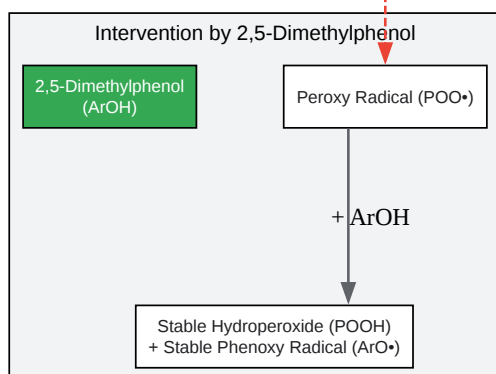

[Click to download full resolution via product page](#)

Free-Radical Scavenging Mechanism of **2,5-Dimethylphenol**.

Quantitative Data Presentation

While specific performance data for **2,5-Dimethylphenol** in common polymers is not readily available in public literature, the following tables present illustrative data based on the typical performance of hindered phenolic antioxidants in polyethylene, polypropylene, and rubber. This data is intended to provide a general understanding of the expected improvements when an antioxidant like **2,5-Dimethylphenol** is incorporated.

Table 1: Illustrative Performance of a Phenolic Antioxidant in Polyethylene (PE)

Property	Unstabilized PE (after aging)	PE with 0.2% Phenolic Antioxidant (after aging)	Test Method
Oxidation Induction Time (OIT) at 200°C (minutes)	< 5	> 60	ASTM D3895[6]
Tensile Strength Retention (%)	40	85	ASTM D638
Elongation at Break Retention (%)	20	70	ASTM D638
Melt Flow Index (g/10 min)	25	8	ASTM D1238[5]

Table 2: Illustrative Performance of a Phenolic Antioxidant in Polypropylene (PP)

Property	Unstabilized PP (after aging)	PP with 0.2% Phenolic Antioxidant (after aging)	Test Method
Oxidation Induction Time (OIT) at 190°C (minutes)	< 3	> 50	ISO 11357-6[7]
Tensile Strength Retention (%)	30	80	ISO 527
Elongation at Break Retention (%)	15	65	ISO 527
Melt Flow Index (g/10 min)	35	10	ISO 1133[5]

Table 3: Illustrative Performance of a Phenolic Antioxidant in a Rubber Formulation

Property	Unstabilized Rubber (after aging)	Rubber with 1.0 phr Phenolic Antioxidant (after aging)	Test Method
Tensile Strength Retention (%)	50	90	ASTM D412
Elongation at Break Retention (%)	40	80	ASTM D412
Hardness Change (Shore A points)	+15	+5	ASTM D2240

Experimental Protocols

Protocol 1: Incorporation of 2,5-Dimethylphenol into Polyethylene via Melt Blending

This protocol describes a standard laboratory procedure for incorporating **2,5-Dimethylphenol** into a polyethylene matrix using a melt blender.

Materials:

- Polyethylene (PE) pellets (e.g., HDPE, LDPE)
- **2,5-Dimethylphenol** powder (analytical grade)
- Internal melt mixer (e.g., Brabender or similar)

Procedure:

- **Drying:** Dry the polyethylene pellets in a vacuum oven at 80°C for at least 4 hours to remove any residual moisture.
- **Mixer Preparation:** Preheat the internal mixer to the desired processing temperature for the specific grade of polyethylene (typically 160-190°C). Set the rotor speed (e.g., 50 rpm).
- **Polymer Melting:** Add the dried polyethylene pellets to the preheated mixer and allow them to melt and form a homogenous melt. This typically takes 3-5 minutes.
- **Antioxidant Addition:** Once the polymer is fully molten, add the desired amount of **2,5-Dimethylphenol** powder directly into the mixing chamber.
- **Melt Compounding:** Continue mixing for a specified duration (e.g., 5-10 minutes) to ensure uniform dispersion of the antioxidant throughout the polymer matrix.
- **Sample Collection:** Stop the mixer and carefully remove the molten polymer blend.
- **Sample Preparation for Analysis:** The collected blend can be compression molded into sheets or films of desired thickness for subsequent analytical testing.

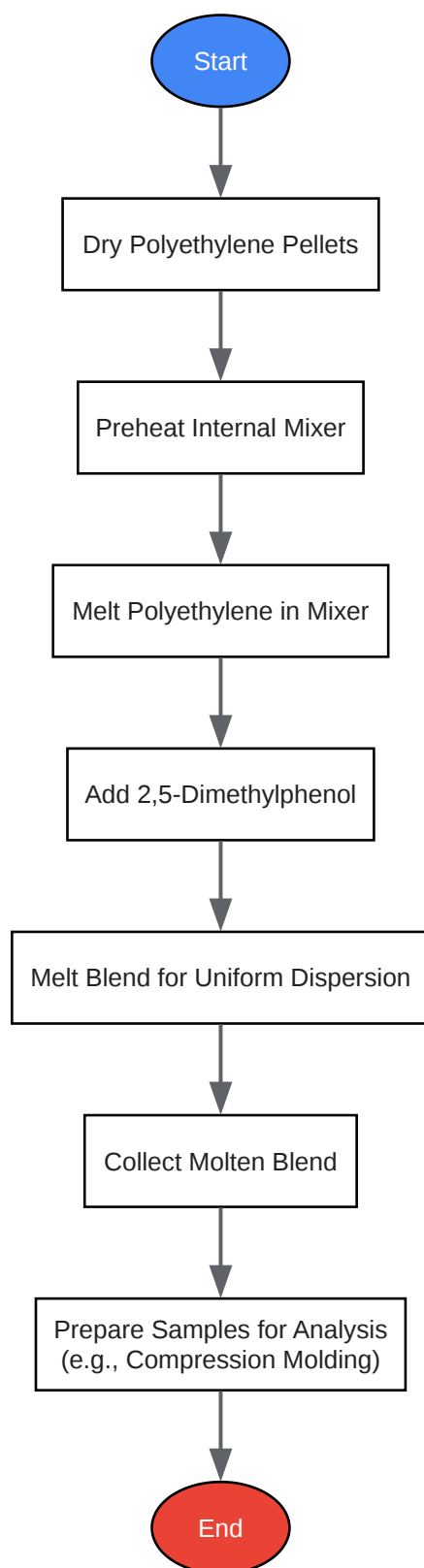

[Click to download full resolution via product page](#)

Workflow for Incorporating **2,5-Dimethylphenol** into Polyethylene.

Protocol 2: Evaluation of Antioxidant Efficacy using Oxidation Induction Time (OIT)

This protocol outlines the procedure for determining the oxidative stability of a polymer stabilized with **2,5-Dimethylphenol** using Differential Scanning Calorimetry (DSC) in accordance with ASTM D3895.[6]

Apparatus:

- Differential Scanning Calorimeter (DSC) with a gas switching accessory.
- Aluminum sample pans.
- High-purity nitrogen and oxygen gas.

Procedure:

- **Sample Preparation:** Prepare a small, uniform disk of the polymer sample (5-10 mg) from the compression-molded sheet. Place the sample in an open aluminum DSC pan.
- **Instrument Setup:** Place the sample pan and an empty reference pan into the DSC cell.
- **Heating under Inert Atmosphere:** Purge the DSC cell with nitrogen at a flow rate of 50 mL/min. Heat the sample from ambient temperature to the isothermal test temperature (e.g., 200°C for polyethylene) at a heating rate of 20°C/min.[4]
- **Isothermal Equilibration:** Hold the sample at the isothermal temperature under the nitrogen atmosphere for 5 minutes to allow for thermal equilibrium.
- **Switch to Oxidizing Atmosphere:** After the equilibration period, switch the purge gas from nitrogen to oxygen at the same flow rate (50 mL/min). This marks the beginning of the OIT measurement (time = 0).
- **Data Acquisition:** Continue to hold the sample at the isothermal temperature under the oxygen atmosphere and record the heat flow signal until a sharp exothermic peak, indicating the onset of oxidation, is observed.

- Data Analysis: The Oxidation Induction Time (OIT) is determined as the time from the switch to the oxygen atmosphere to the onset of the exothermic oxidation peak.[8]

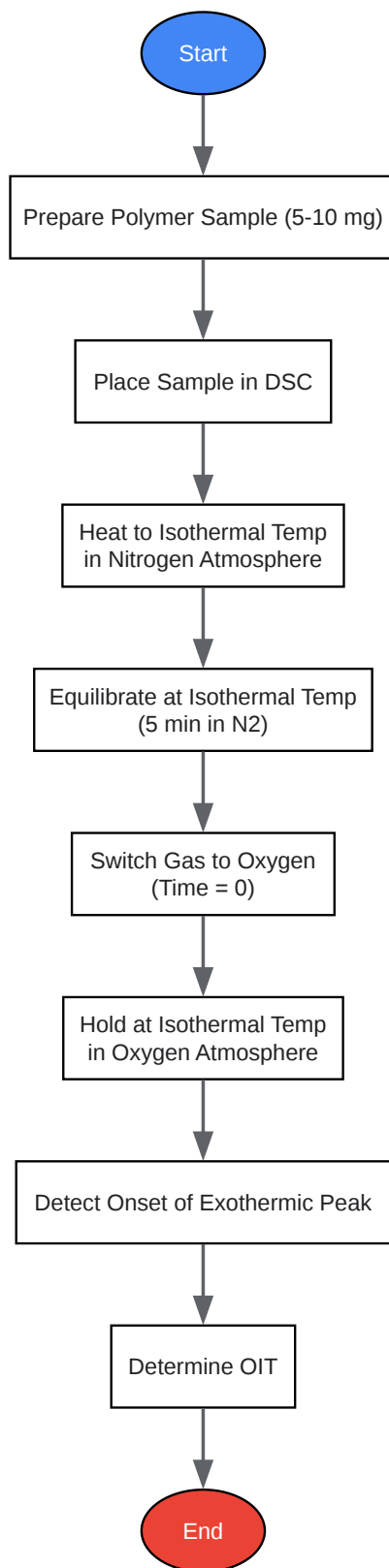

[Click to download full resolution via product page](#)

Experimental Workflow for OIT Measurement.

Conclusion

2,5-Dimethylphenol serves as a potent antioxidant for a variety of polymeric materials by effectively scavenging free radicals and inhibiting oxidative degradation. The provided protocols offer standardized methods for its incorporation and for the quantitative evaluation of its performance. While specific performance data for **2,5-Dimethylphenol** is limited, the illustrative data presented for similar phenolic antioxidants highlight the significant improvements in material stability that can be expected. For researchers and professionals in materials science and drug development, **2,5-Dimethylphenol** represents a valuable tool for enhancing the durability and reliability of polymer-based products and devices.

Need Custom Synthesis?

BenchChem offers custom synthesis for rare earth carbides and specific isotopic labeling.

Email: info@benchchem.com or [Request Quote Online](#).

References

- 1. Antioxidant Silicone Elastomers without Covalent Cross-Links - PMC [pmc.ncbi.nlm.nih.gov]
- 2. Acid Treatment Enhances the Antioxidant Activity of Enzymatically Synthesized Phenolic Polymers [mdpi.com]
- 3. acgpubs.org [acgpubs.org]
- 4. specialchem.com [specialchem.com]
- 5. alpha-plast.com.ua [alpha-plast.com.ua]
- 6. hitachi-hightech.com [hitachi-hightech.com]
- 7. researchgate.net [researchgate.net]
- 8. thermalsupport.com [thermalsupport.com]
- To cite this document: BenchChem. [Application Notes and Protocols: 2,5-Dimethylphenol as an Antioxidant in Materials Science]. BenchChem, [2025]. [Online PDF]. Available at:

[<https://www.benchchem.com/product/b165462#using-2-5-dimethylphenol-as-an-antioxidant-in-materials-science>]

Disclaimer & Data Validity:

The information provided in this document is for Research Use Only (RUO) and is strictly not intended for diagnostic or therapeutic procedures. While BenchChem strives to provide accurate protocols, we make no warranties, express or implied, regarding the fitness of this product for every specific experimental setup.

Technical Support: The protocols provided are for reference purposes. Unsure if this reagent suits your experiment? [[Contact our Ph.D. Support Team for a compatibility check](#)]

Need Industrial/Bulk Grade? [Request Custom Synthesis Quote](#)

BenchChem

Our mission is to be the trusted global source of essential and advanced chemicals, empowering scientists and researchers to drive progress in science and industry.

Contact

Address: 3281 E Guasti Rd
Ontario, CA 91761, United States
Phone: (601) 213-4426
Email: info@benchchem.com