

Navigating the Handling of MZP-55: A Comprehensive Safety and Operational Guide

Author: BenchChem Technical Support Team. **Date:** April 2026

Compound of Interest

Compound Name:	MZP-55
CAS No.:	2010159-48-3
Cat. No.:	B1649326

[Get Quote](#)

For researchers, scientists, and drug development professionals, the safe and effective handling of novel compounds is paramount. This document provides essential, immediate safety and logistical information for the PROTAC BET degrader, **MZP-55**. As a compound intended for research use only, adherence to stringent laboratory safety protocols is critical. This guide offers procedural, step-by-step guidance to directly address operational questions, ensuring the well-being of laboratory personnel and the integrity of research outcomes.

Immediate Safety and Handling Precautions

While a specific Safety Data Sheet (SDS) for **MZP-55** is not publicly available, the following guidelines are based on best practices for handling potent, biologically active research compounds and general knowledge of PROTAC BET degraders. A thorough risk assessment should be conducted by qualified personnel before handling this compound.

Personal Protective Equipment (PPE): The level of PPE required depends on the nature of the handling procedure. The following table summarizes recommended PPE for various laboratory operations involving **MZP-55**.

Operation	Recommended Personal Protective Equipment
Weighing and preparing solutions	<ul style="list-style-type: none"> - Disposable nitrile gloves (double-gloving recommended)- Laboratory coat- Safety glasses with side shields or chemical splash goggles- Particulate respirator (e.g., N95) or use of a certified chemical fume hood
Cell culture and in vitro assays	<ul style="list-style-type: none"> - Disposable nitrile gloves- Laboratory coat- Safety glasses
Animal handling (if applicable)	<ul style="list-style-type: none"> - Disposable nitrile gloves- Solid-front laboratory gown- Safety glasses- Respiratory protection as determined by risk assessment
Waste disposal	<ul style="list-style-type: none"> - Disposable nitrile gloves- Laboratory coat- Safety glasses

General Handling Procedures:

- **Engineering Controls:** All handling of solid **MZP-55** and preparation of concentrated stock solutions should be performed in a certified chemical fume hood or other suitable containment device to minimize inhalation exposure.
- **Personal Hygiene:** Avoid direct contact with skin, eyes, and clothing. Wash hands thoroughly with soap and water after handling and before leaving the laboratory.
- **Spill Management:** In the event of a spill, immediately evacuate the area and alert laboratory safety personnel. Small spills of solutions can be absorbed with an inert material and collected for proper disposal. For larger spills or spills of solid material, follow established emergency procedures.

Operational and Disposal Plans

A clear plan for the use and disposal of **MZP-55** is essential for maintaining a safe laboratory environment.

Experimental Workflow: The following diagram outlines a typical experimental workflow for in vitro studies using **MZP-55**.

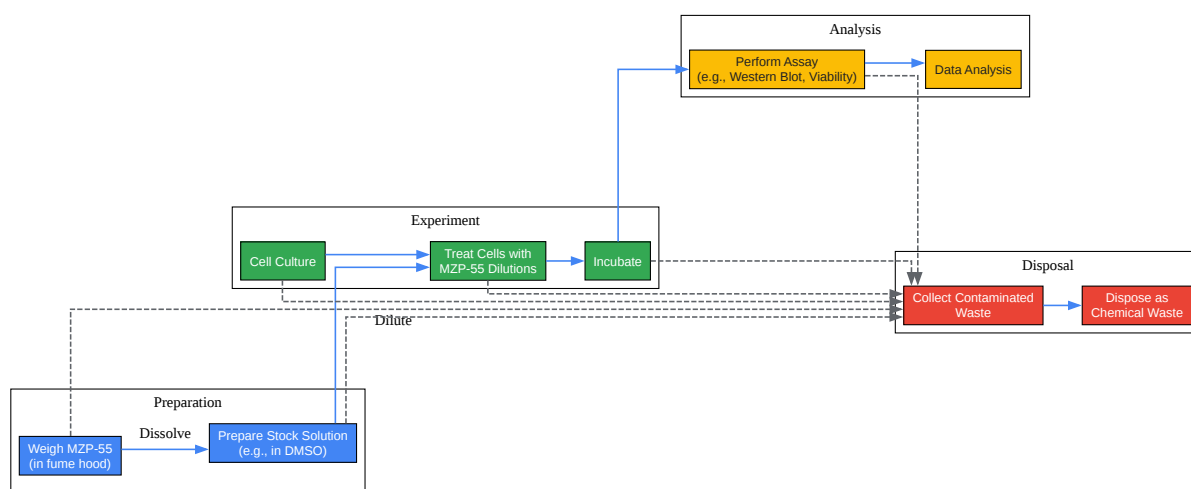

[Click to download full resolution via product page](#)

Experimental workflow for in vitro studies with **MZP-55**.

Disposal Plan: All waste contaminated with **MZP-55**, including unused solutions, contaminated labware (e.g., pipette tips, tubes), and PPE, must be disposed of as hazardous chemical

waste. Follow all local, state, and federal regulations for chemical waste disposal. A logical relationship for the disposal decision-making process is outlined below.

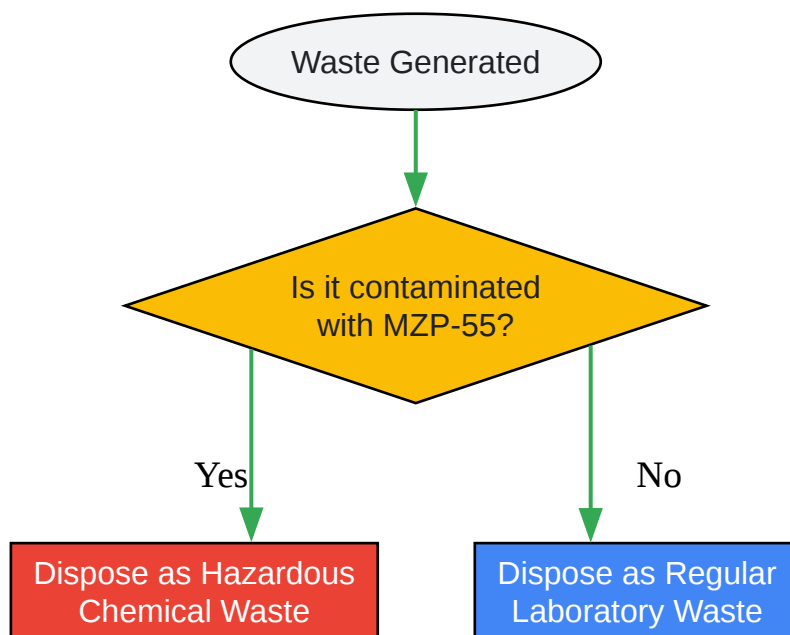

[Click to download full resolution via product page](#)

Decision-making process for **MZP-55** waste disposal.

Experimental Protocols

Detailed methodologies for key experiments are crucial for reproducibility and safety.

General Protocol for In Vitro Cell-Based Assays:

- Cell Seeding: Plate cells in appropriate well plates at a density determined by the specific cell line and assay duration. Allow cells to adhere overnight.
- Compound Preparation: Prepare a stock solution of **MZP-55** in a suitable solvent, such as dimethyl sulfoxide (DMSO). Create a serial dilution of the stock solution in cell culture medium to achieve the desired final concentrations.
- Cell Treatment: Remove the existing medium from the cells and replace it with the medium containing the various concentrations of **MZP-55**. Include a vehicle control (medium with the same concentration of DMSO as the highest **MZP-55** concentration).

- Incubation: Incubate the cells for the desired time period (e.g., 24, 48, 72 hours) under standard cell culture conditions (e.g., 37°C, 5% CO₂).
- Assay Performance: Following incubation, perform the desired assay to assess the effects of **MZP-55**. This could include, but is not limited to:
 - Western Blotting: To analyze the degradation of target proteins (e.g., BRD4).
 - Cell Viability/Proliferation Assays (e.g., MTS, CellTiter-Glo): To determine the effect on cell growth.
 - qRT-PCR: To measure changes in gene expression.
- Data Analysis: Analyze the data using appropriate statistical methods to determine key parameters such as DC₅₀ (concentration for 50% degradation) or IC₅₀ (concentration for 50% inhibition).

By adhering to these safety and operational guidelines, researchers can confidently and responsibly work with **MZP-55**, fostering a secure and productive research environment. This commitment to safety not only protects laboratory personnel but also upholds the integrity and quality of scientific discovery.

- To cite this document: BenchChem. [Navigating the Handling of MZP-55: A Comprehensive Safety and Operational Guide]. BenchChem, [2026]. [Online PDF]. Available at: [<https://www.benchchem.com/product/b1649326/docs#navigating-the-handling-of-mzp-55-a-comprehensive-safety-and-operational-guide>]

Disclaimer & Data Validity:

The information provided in this document is for Research Use Only (RUO) and is strictly not intended for diagnostic or therapeutic procedures. While BenchChem strives to provide accurate protocols, we make no warranties, express or implied, regarding the fitness of this product for every specific experimental setup.

Technical Support: The protocols provided are for reference purposes. Unsure if this reagent suits your experiment?

Need Industrial/Bulk Grade? [Request Custom Synthesis Quote](#)

BenchChem

Our mission is to be the trusted global source of essential and advanced chemicals, empowering scientists and researchers to drive progress in science and industry.

Contact

Address: 3281 E Guasti Rd
Ontario, CA 91761, United States
Phone: (601) 213-4426
Email: info@benchchem.com

[Contact our Ph.D. Support Team for a compatibility check](#)