

# Application Notes and Protocols: Tungsten Hydroxide in Electrochromic Devices

**Author:** BenchChem Technical Support Team. **Date:** April 2026

## Compound of Interest

Compound Name: Tungsten hydroxide

CAS No.: 107477-35-0

Cat. No.: B1649897

[Get Quote](#)

Authored for: Researchers, Scientists, and Drug Development Professionals

## Introduction

Tungsten-based materials are at the forefront of electrochromic technology, which enables the reversible change of optical properties upon the application of a small voltage. While often referred to as tungsten oxide ( $\text{WO}_3$ ), the hydrated form, **tungsten hydroxide** (effectively hydrated tungsten oxide,  $\text{WO}_3 \cdot n\text{H}_2\text{O}$ ), plays a pivotal role in enhancing the performance of electrochromic devices. The presence of structural water within the tungsten oxide matrix facilitates ion intercalation and deintercalation, leading to significant improvements in switching kinetics, coloration efficiency, and long-term stability.<sup>[1][2][3][4]</sup>

These application notes provide a comprehensive overview of the synthesis of **tungsten hydroxide**-based materials and their application in the fabrication of electrochromic devices. Detailed experimental protocols, performance data, and workflow diagrams are presented to guide researchers in this field.

## Data Presentation: Performance of Hydrated Tungsten Oxide Electrochromic Materials

The following tables summarize the key performance metrics of electrochromic devices employing hydrated tungsten oxide, synthesized via various methods.

Material	Synthesis Method	Transmittance Modulation (%)	Coloration Efficiency (CE) (cm <sup>2</sup> /C)	Switching Speed (Coloration/Bleaching) (s)	Cycling Stability	Reference
WO <sub>3</sub> ·2H <sub>2</sub> O	Acid Precipitation	90.4% (NIR)	322.6	-	93.7% retention after 500 cycles	[1]
WO <sub>3</sub> ·H <sub>2</sub> O	Acid Precipitation	Dual-band (NIR then visible)	-	-	-	[2]
WO <sub>3</sub> ·0.33H <sub>2</sub> O	Hydrothermal with seed layer	-	-	-	-	
Amorphous Hydrated WO <sub>3</sub>	-	-	-	-	Enhanced pseudocapacitive contribution	
WO <sub>3</sub> /ITO Nanocomposite	Acid-assisted hydrothermal	87.89% at 633 nm	154.16	-	Enhanced	

Note: "-" indicates data not specified in the cited sources.

## Experimental Protocols

### Protocol 1: Synthesis of Hydrated Tungsten Oxide ( $\text{WO}_3 \cdot n\text{H}_2\text{O}$ ) Nanoplates via Acid Precipitation

This protocol describes the synthesis of hydrated tungsten oxide nanoplates with controlled water content, adapted from the literature.[\[1\]](#)

#### Materials:

- Sodium Tungstate Dihydrate ( $\text{Na}_2\text{WO}_4 \cdot 2\text{H}_2\text{O}$ )
- Hydrochloric Acid (HCl, 3 M)
- Deionized (DI) water
- Ethanol

#### Equipment:

- Beakers and magnetic stirrer
- Centrifuge and centrifuge tubes
- Oven or furnace
- Freeze-dryer

#### Procedure:

- **Precursor Solution Preparation:** Dissolve Sodium Tungstate Dihydrate in DI water to form a 0.1 M solution.
- **Acidification:** While stirring vigorously, rapidly add 3 M HCl to the sodium tungstate solution until the pH reaches 1. A white precipitate of tungstic acid will form.
- **Aging and Crystallization:**
  - To obtain  $\text{WO}_3 \cdot 2\text{H}_2\text{O}$ , age the solution at room temperature for 24 hours.

- To obtain  $\text{WO}_3 \cdot \text{H}_2\text{O}$ , age the solution at  $90^\circ\text{C}$  for 24 hours.
- Washing: Centrifuge the precipitate and wash it repeatedly with DI water and then ethanol to remove any remaining ions.
- Drying: Freeze-dry the washed precipitate to obtain the final hydrated tungsten oxide powder.
- (Optional) Anhydrous  $\text{WO}_3$ : To obtain anhydrous  $\text{WO}_3$  for comparison, anneal the  $\text{WO}_3 \cdot 2\text{H}_2\text{O}$  powder at  $350^\circ\text{C}$  for 2 hours.

## Protocol 2: Fabrication of a Hydrated Tungsten Oxide Electrochromic Film via Sol-Gel Method

This protocol outlines the fabrication of an electrochromic film using a sol-gel method starting from tungstic acid.[\[5\]](#)[\[6\]](#)[\[7\]](#)

Materials:

- Tungsten powder
- Hydrogen peroxide ( $\text{H}_2\text{O}_2$ , 30%)
- Ethanol
- Transparent conductive oxide (TCO) coated glass substrates (e.g., FTO or ITO)

Equipment:

- Beakers and magnetic stirrer
- Spin coater or dip coater
- Hot plate or oven

Procedure:

- Sol Preparation (Peroxtungstic Acid Route):

- Slowly add tungsten powder to a 30% hydrogen peroxide solution under constant stirring in an ice bath.
- Continue stirring until the tungsten powder is completely dissolved, forming a clear yellow peroxotungstic acid solution.
- Filter the solution to remove any undissolved particles.
- Add ethanol to the solution to form the coating sol.
- Substrate Preparation: Clean the TCO-coated glass substrates sequentially with detergent, DI water, acetone, and isopropanol in an ultrasonic bath. Dry the substrates with a stream of nitrogen gas.
- Film Deposition:
  - Spin Coating: Dispense the sol onto the TCO substrate and spin at a desired speed (e.g., 1000-3000 rpm) for a set duration (e.g., 30-60 seconds).
  - Dip Coating: Dip the TCO substrate into the sol and withdraw it at a controlled speed.
- Drying and Annealing:
  - Dry the coated film on a hot plate or in an oven at a low temperature (e.g., 80-100°C) to evaporate the solvent.
  - Anneal the film at a higher temperature (e.g., 120-200°C) to form a stable hydrated tungsten oxide film. The annealing temperature will affect the degree of hydration and crystallinity.

## Protocol 3: Assembly and Characterization of an Electrochromic Device

Materials:

- Hydrated tungsten oxide coated TCO substrate (working electrode)
- Counter electrode (e.g., Prussian Blue coated TCO substrate or a Li-ion storage material)

- Electrolyte (e.g., 1 M LiClO<sub>4</sub> in propylene carbonate)
- Sealant (e.g., epoxy resin)
- Spacers (e.g., thin polymer film)

#### Equipment:

- Glovebox (for non-aqueous electrolytes)
- Potentiostat/Galvanostat
- UV-Vis Spectrophotometer

#### Procedure:

- Device Assembly:
  - Place the hydrated tungsten oxide coated substrate and the counter electrode facing each other, separated by a spacer.
  - Inject the electrolyte into the space between the electrodes.
  - Seal the edges of the device with an appropriate sealant to prevent leakage.
- Electrochemical Characterization:
  - Connect the working and counter electrodes to a potentiostat.
  - Perform cyclic voltammetry (CV) to investigate the ion insertion/extraction behavior and determine the operating voltage window.
  - Use chronoamperometry to measure the switching speed by applying a potential step and monitoring the current response.
- Spectroelectrochemical Characterization:
  - Place the assembled device in the sample holder of a UV-Vis spectrophotometer.

- Apply different potentials to the device and record the corresponding optical transmittance spectra to determine the transmittance modulation.
- Calculate the coloration efficiency (CE) from the change in optical density and the injected/ejected charge.

## Mandatory Visualizations

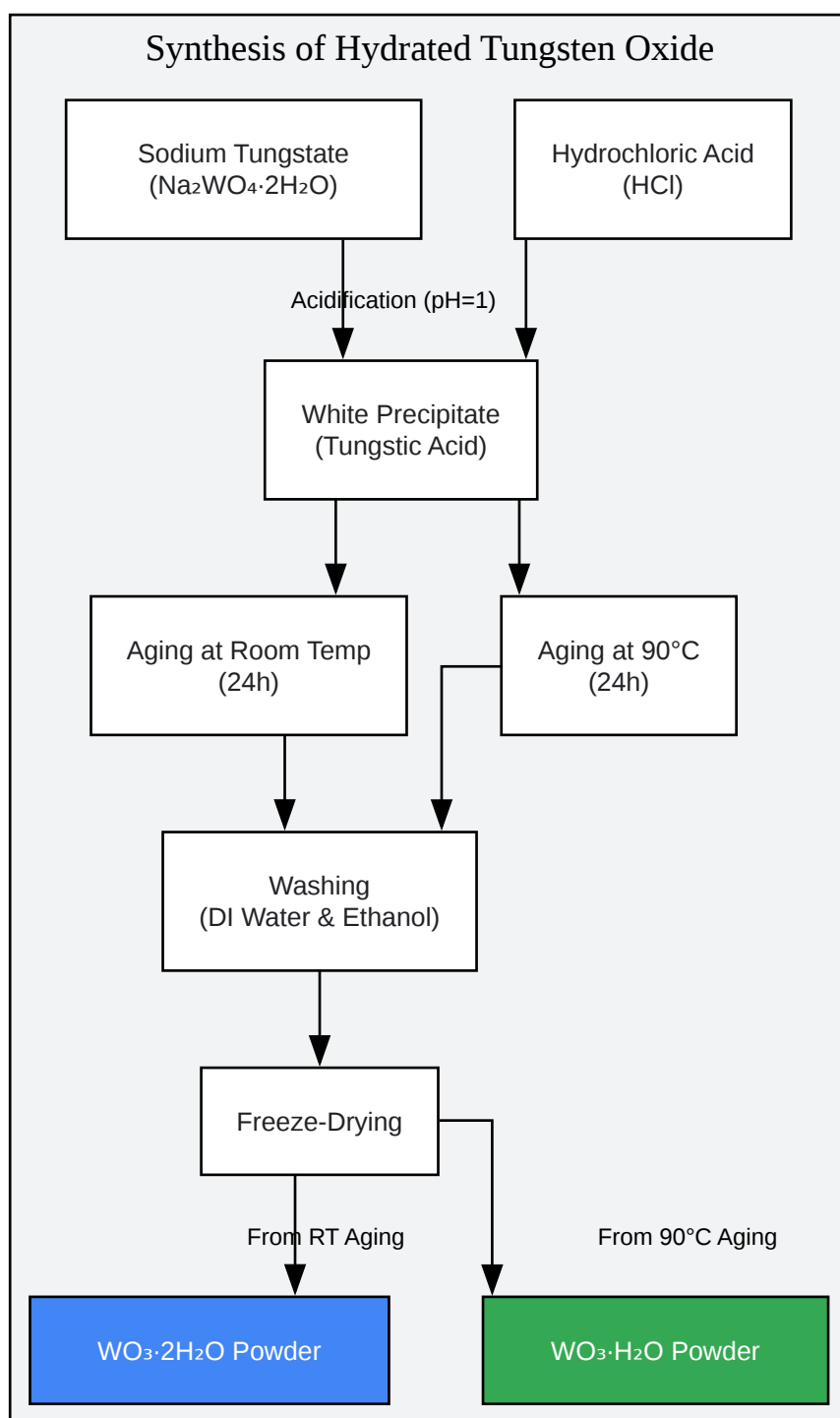

[Click to download full resolution via product page](#)

Caption: Synthesis of Hydrated Tungsten Oxide via Acid Precipitation.

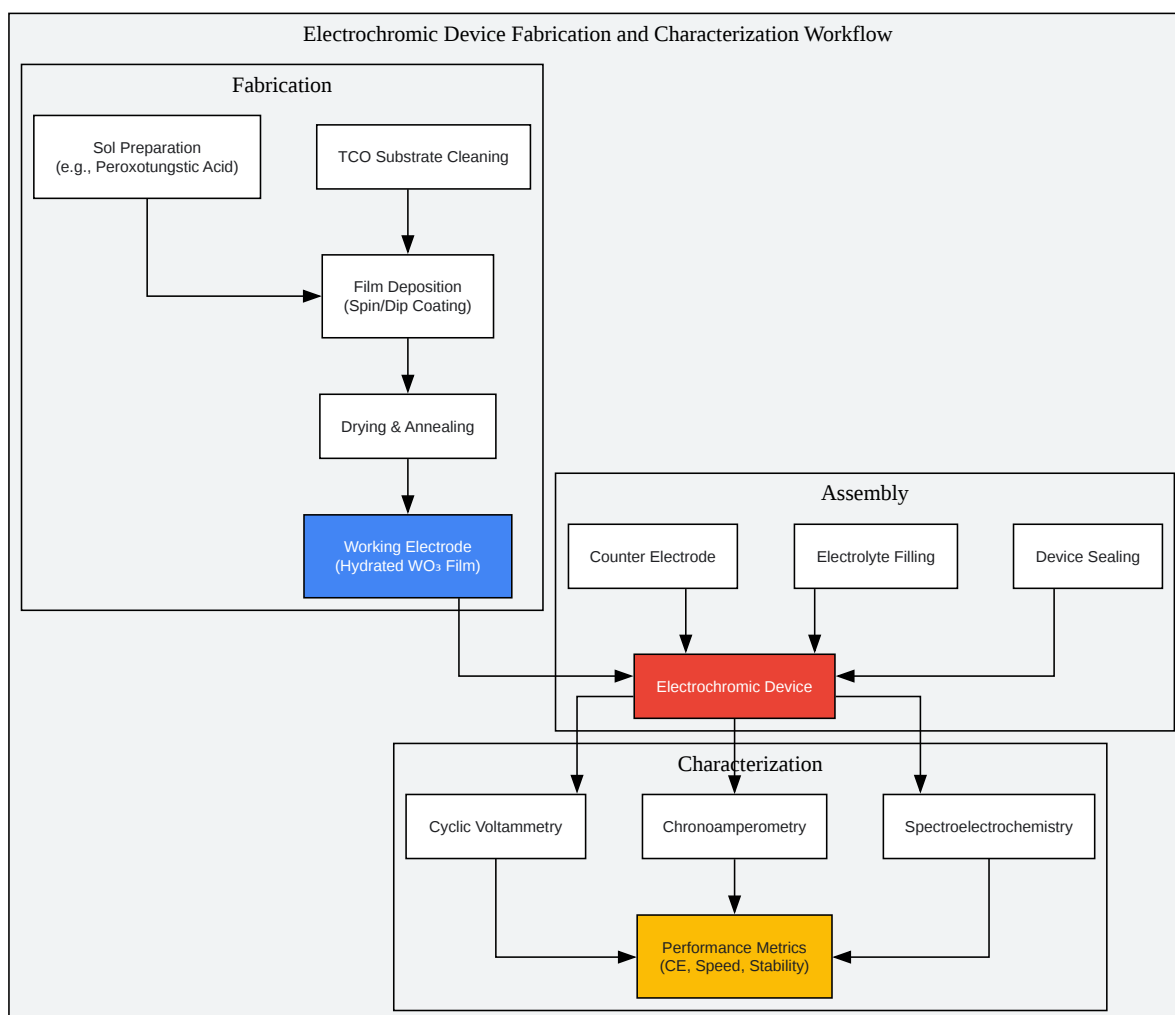

[Click to download full resolution via product page](#)

Caption: Workflow for Electrochromic Device Fabrication and Testing.

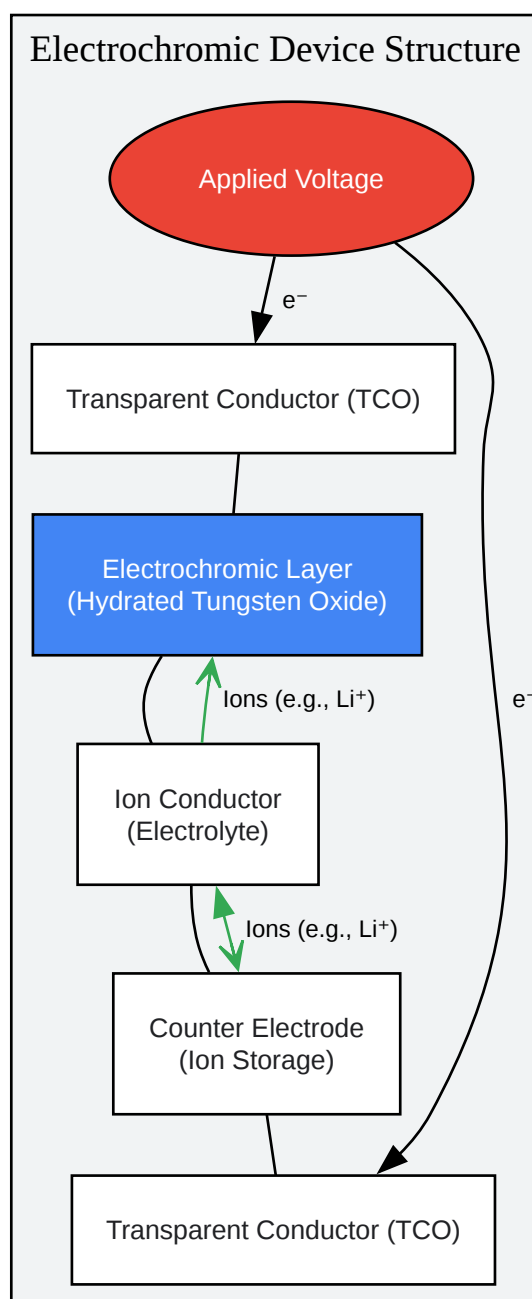

[Click to download full resolution via product page](#)

Caption: Structure of a Hydrated Tungsten Oxide Electrochromic Device.

### Need Custom Synthesis?

BenchChem offers custom synthesis for rare earth carbides and specific isotopic labeling.

Email: [info@benchchem.com](mailto:info@benchchem.com) or [Request Quote Online](#).

## References

- [1. pubs.acs.org \[pubs.acs.org\]](#)
- [2. pubs.acs.org \[pubs.acs.org\]](#)
- [3. Electrochromism in hydrated tungsten-oxide films | Electronics Letters \[digital-library.theiet.org\]](#)
- [4. Electrochromism in hydrated tungsten-oxide films | Semantic Scholar \[semanticscholar.org\]](#)
- [5. Tungsten Oxide Thin Film Sol-gel Method !\[\]\(73937a8f461f9a87bc32687d38d0d956\_img.jpg\) Chinatungsten Online \[tungsten-film.com\]](#)
- [6. news.chinatungsten.com \[news.chinatungsten.com\]](#)
- [7. researchgate.net \[researchgate.net\]](#)
- To cite this document: BenchChem. [Application Notes and Protocols: Tungsten Hydroxide in Electrochromic Devices]. BenchChem, [2026]. [Online PDF]. Available at: [\[https://www.benchchem.com/product/b1649897/docs#application-notes-and-protocols-tungsten-hydroxide-in-electrochromic-devices\]](https://www.benchchem.com/product/b1649897/docs#application-notes-and-protocols-tungsten-hydroxide-in-electrochromic-devices)

---

### Disclaimer & Data Validity:

The information provided in this document is for Research Use Only (RUO) and is strictly not intended for diagnostic or therapeutic procedures. While BenchChem strives to provide accurate protocols, we make no warranties, express or implied, regarding the fitness of this product for every specific experimental setup.

**Technical Support:** The protocols provided are for reference purposes. Unsure if this reagent suits your experiment?

**Need Industrial/Bulk Grade?** [Request Custom Synthesis Quote](#)

# BenchChem

Our mission is to be the trusted global source of essential and advanced chemicals, empowering scientists and researchers to drive progress in science and industry.

## Contact

Address: 3281 E Guasti Rd

Ontario, CA 91761, United States

Phone: (601) 213-4426

Email: [info@benchchem.com](mailto:info@benchchem.com)

[Contact our Ph.D. Support Team for a compatibility check](#)